

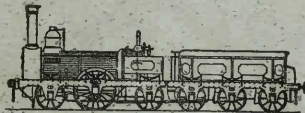

**Tegninger og fotos  
af**



**danske lokomotiver og vogne  
med sporplaner, bygninger o. l.  
for  
modeljernbanebyggere**



Hefte 1 . Kr. 3,50

## Indhold

DSBs hurtigtogslokomotiv litra E II	2	DSB åben godsvogn litra PB	30
DSB motorvogne og lokomotiver	5	DSB kølevogn litra IKN	31
Private motorvogne og lokomotiver	6	DSB hvidmalet kødvogn litra IKT	31
DSB vogne	7	Privatejede gods- og cisternevogne:	
Bogietyper	8	cisternevogn litra ZE	32
DSBs 3-vogns lyntog, dieselelektriske motortog		krukkevogn litra ZS	33
litra MS-AA-MS	9	gær- og melassevogn litra ZB-ZE	33
DSBs benzin-mekaniske motorvogn litra ME	12	ølvogne litra Za-Zb	34
Danske privatbaners 275 HK diesel-		cisternevogn litra ZE	35
elektriske lokomotiv	14	Maskinkølevogn litra ZM	35
Danske Statsbaners litra ML diesel-elektriske		cisternevogn litra ZE	36
motorvogn	15	DSBs svinefold med fast rampe	37
DSBs litra PR 930	18	DSBs 2-sporet remise for motorvogne	38
Skinnebus	19	DSBs vandtårn	39
DSBs personvogn litra AC	20	Drejeskive	39
DSBs personvogn litra AF	22	DSBs signaler	40
Odsherreds Jernbanes to-akslede		Detaller vedr. opbygning af anlæg	41
personvogn A 202	23	Broer	42
DSBs postvogn litra DO	24	Sporskiftebygning	43
DSBs rejsegodsvogn litra EH	26	Pufferbygning	45
Det internationale Sovevogns Selskab,		Stoppebom	45
1. og 2. classes vogn, sovevogn	27	Sporplaner	46
spisevogn	28		
DSB lukket godsvogn litra QH	29	Standardblade	omslaget

Tegninger og fotos  
af  
danske lokomotiver og vogne  
med sporplaner, bygninger o. l.  
for  
modeljernbanebyggere

Hefte 1

Særtryk af de bedste  
tegninger og fotos fra »Modeljernbanen«  
1. og 2. årgang



Udgivet af  
Modeljernbanen . Tidsskrift for jernbaner og modeljernbaner

D. S. B.s  
hurtigtogslokomotiv  
litra E II

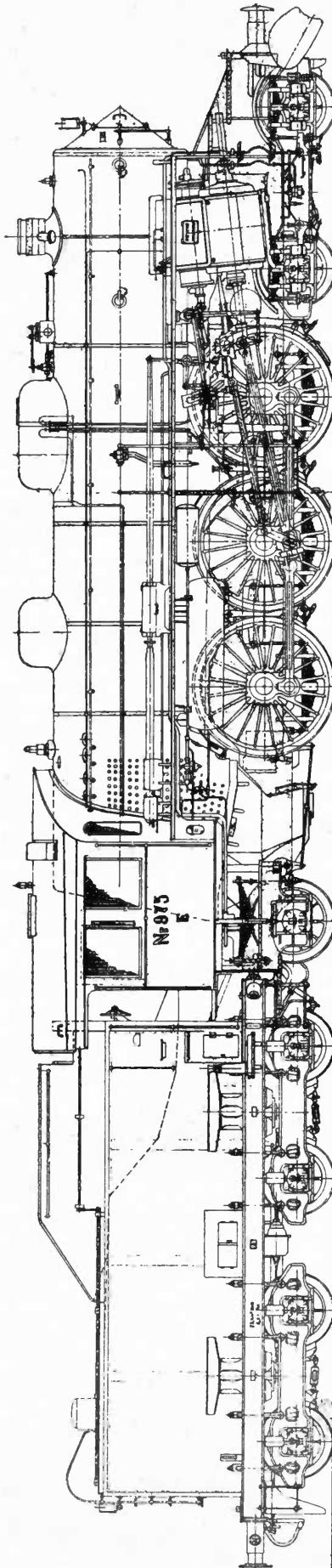
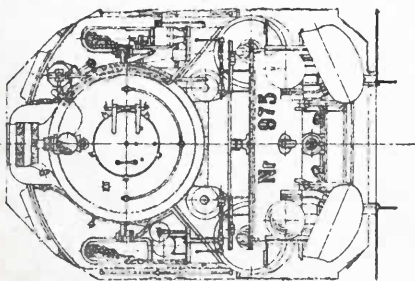
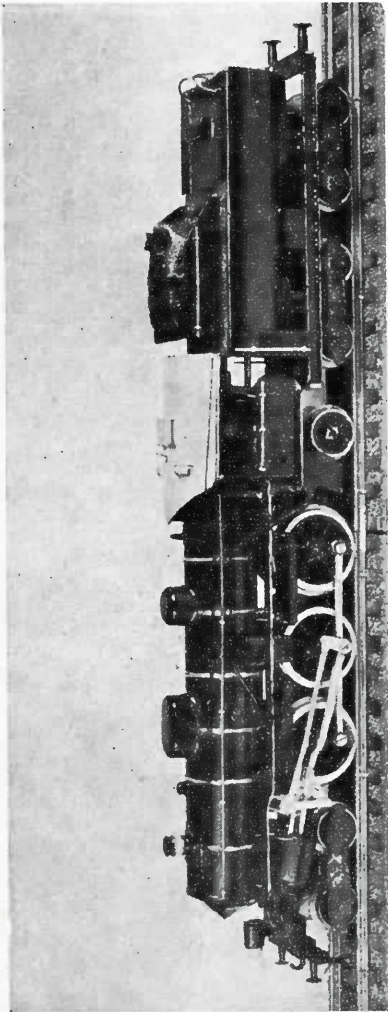

Adlestok 1/87 - Spor H0

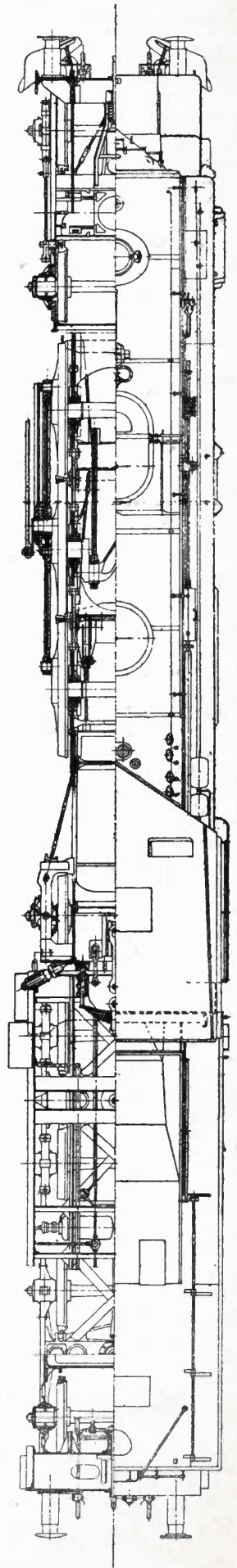

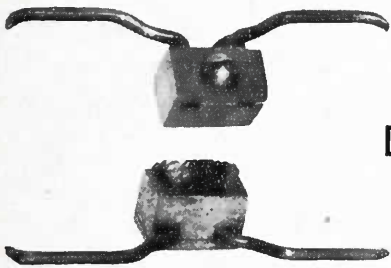
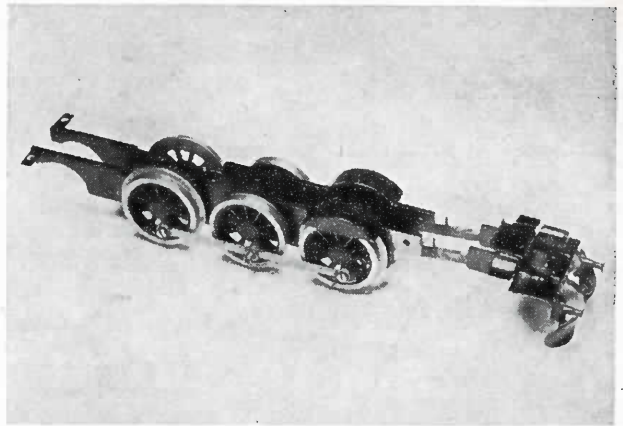
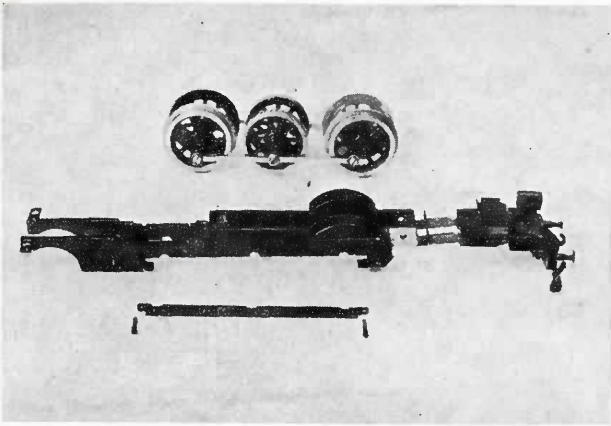

Detailfotos

Strømaftager

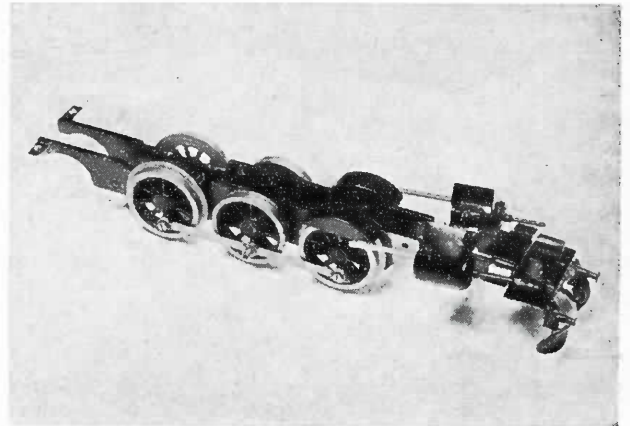

Ramme

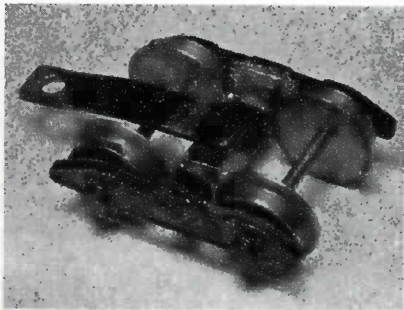

Forløber

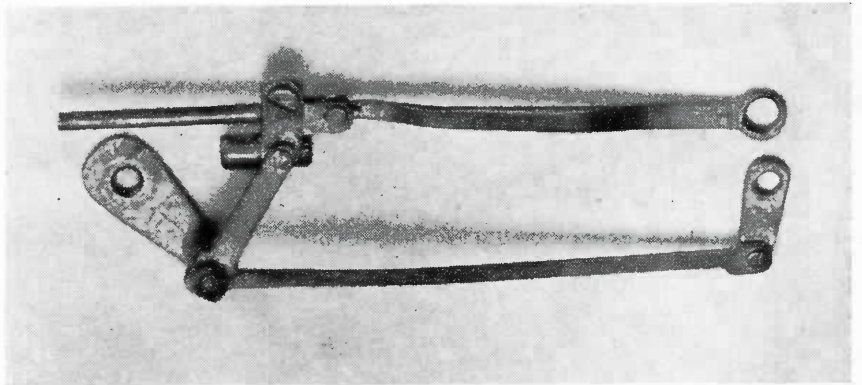

Styretøj

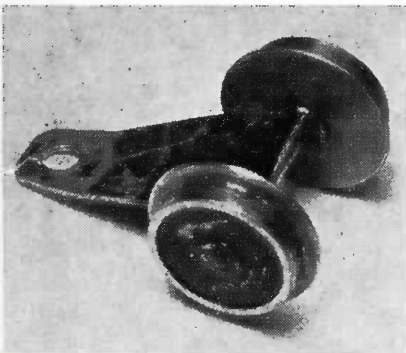

Bagløber

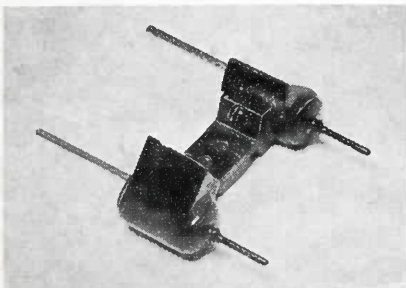

Cylindre

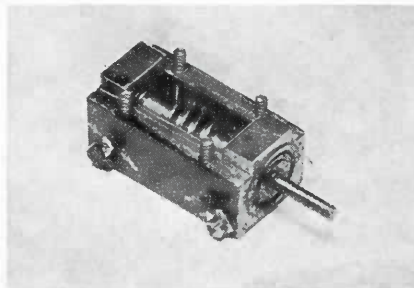

Gearkasse

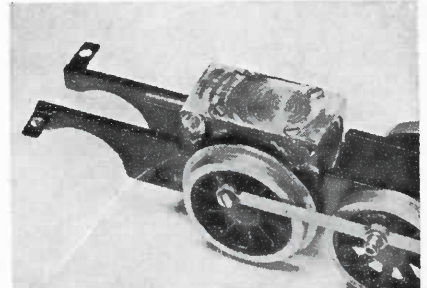

Gearkasse på ramme

# Detailtegninger

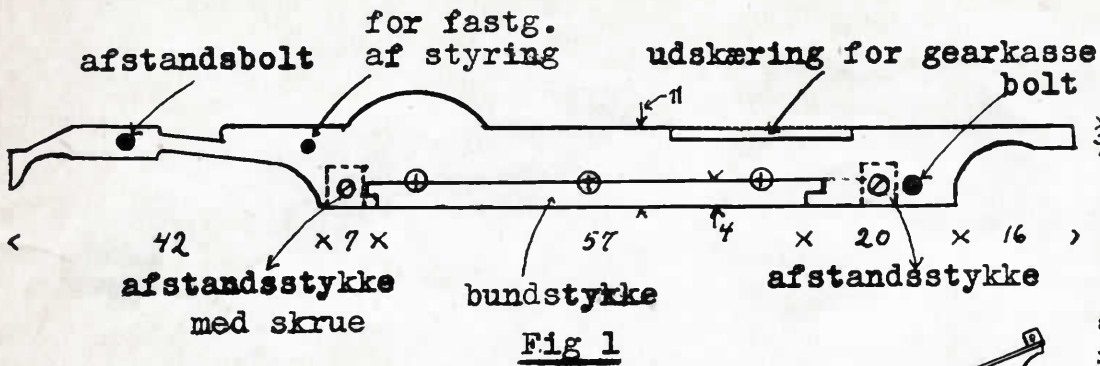
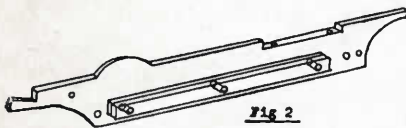
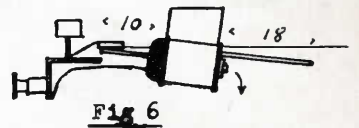
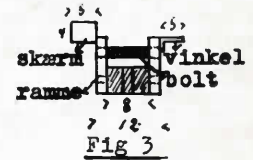
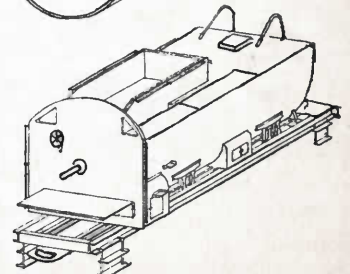
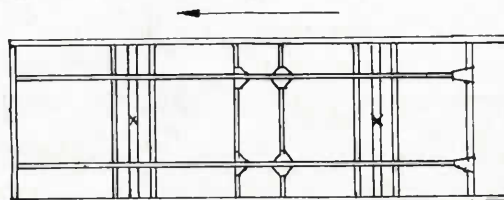
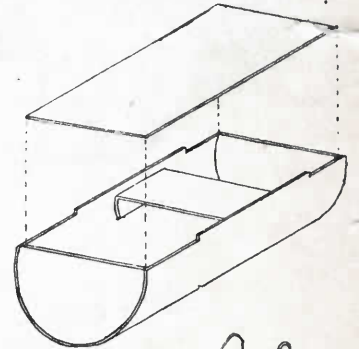
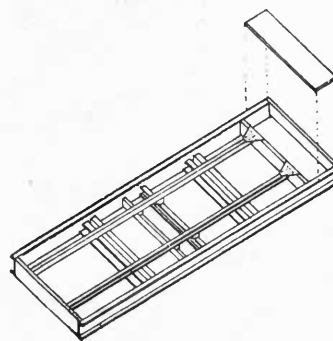
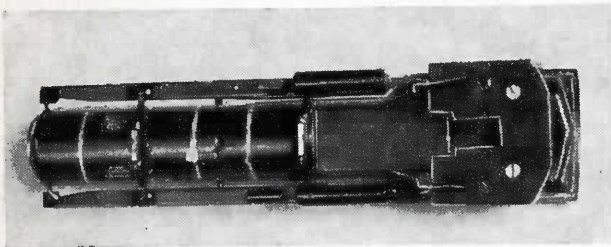
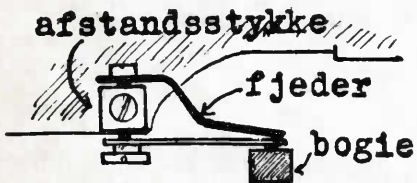
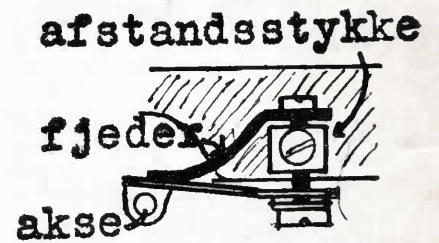
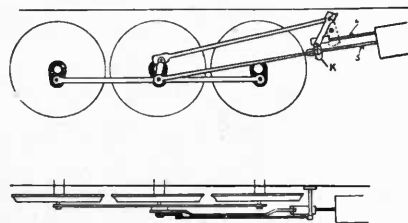
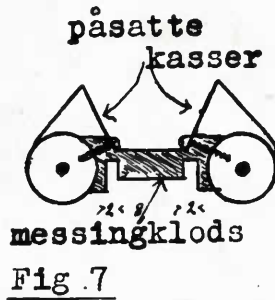
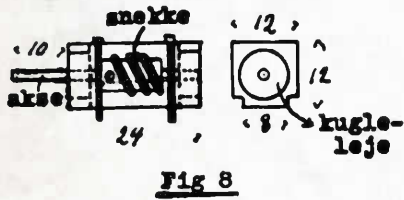
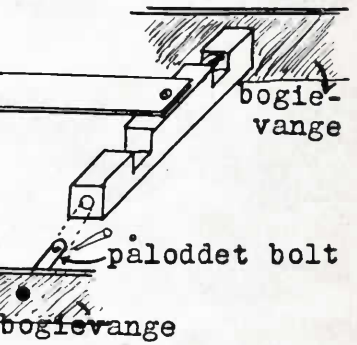
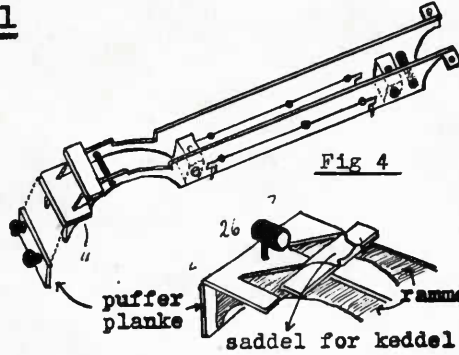

Fig 1



Pålodningen af kobbelstængerne under boringen



# DSB motorvogne og lokomotiver

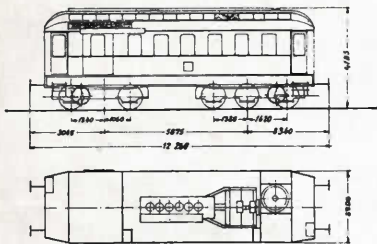

Statsbanerne DSB MW 117, 118 1929

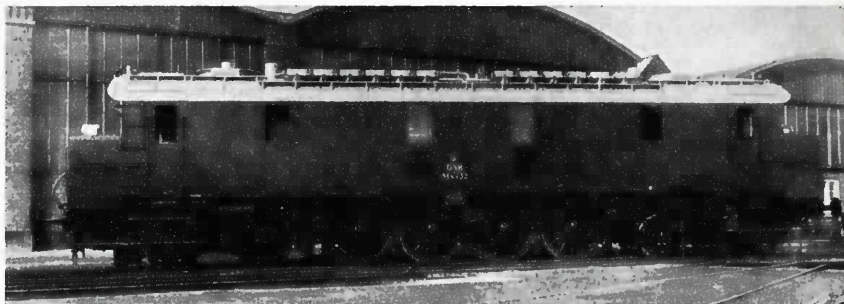

DSB litra MX 132, 1932

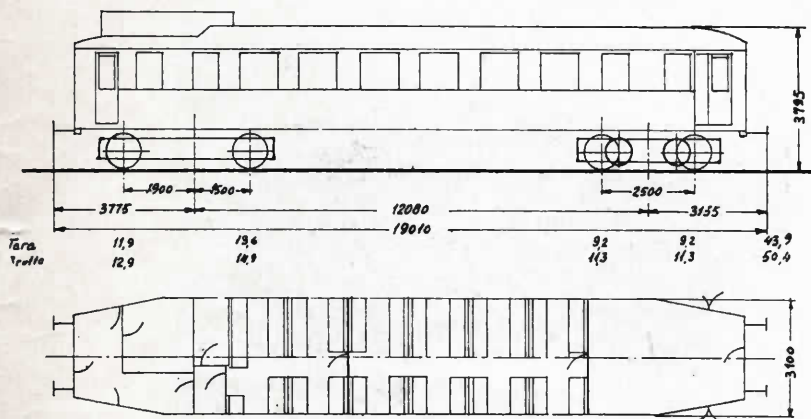

Statsbanerne MR 531, 532. 1928

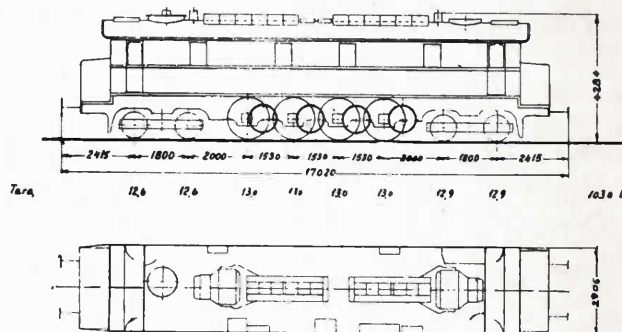

DSB litra MQ 521, 524. 1932

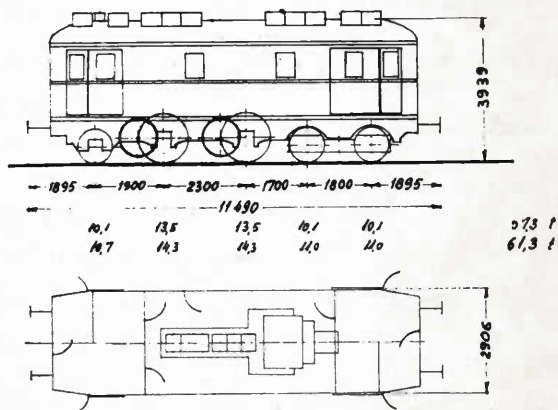

Statsbanerne DSB MV 115, 116. 1929

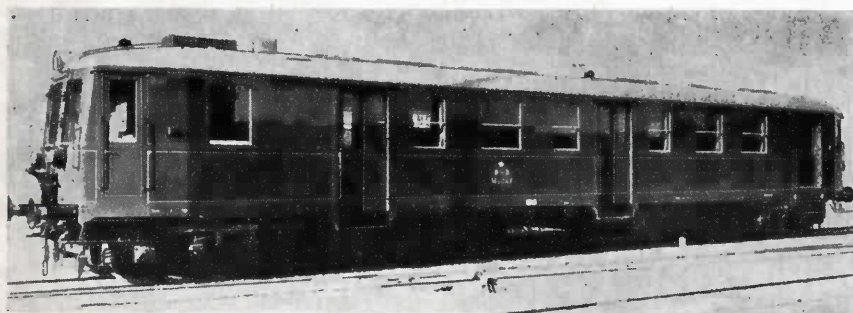

DSB litra MO 288

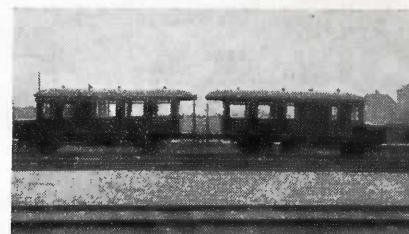

# Privatbane motorvogne og lokomotiver

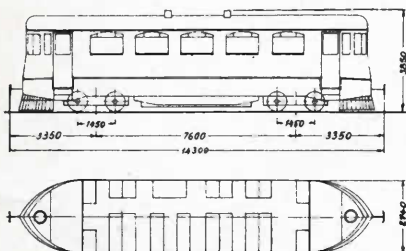

Haderslevs Amtsbanners HAJ M 1-10  
1922-1923

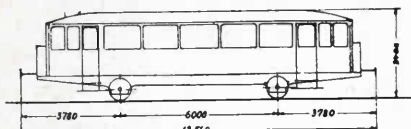

Amagerbanen AB M 1, 1923.  
Kolding Sydbaner KS M 1, 1924

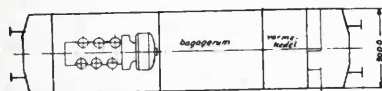
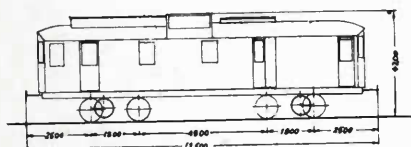

Amagerbanen AB M 2, 1924

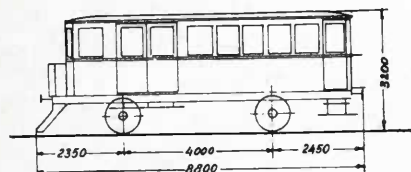

Aarhus-Hammel-Thorsø AHTJ M 1-2,  
1923

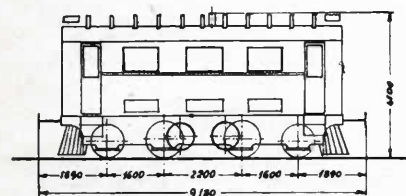

Kolding Sydbaner KS, M3, 1931

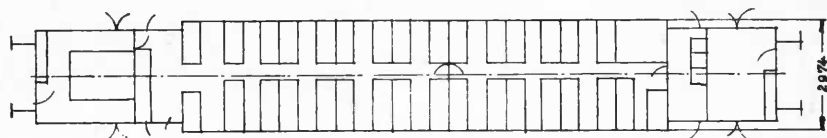
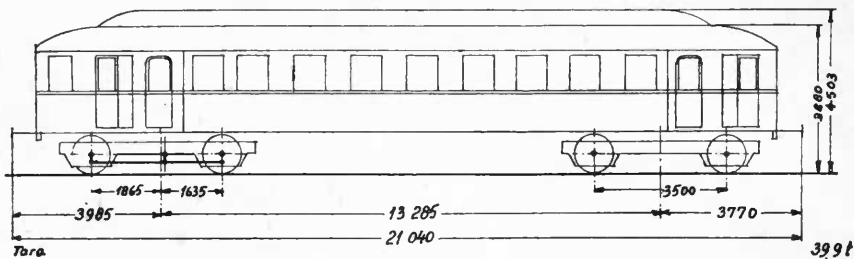

Mariager-Faarup-Viborg Jb. M 1-2, 1927

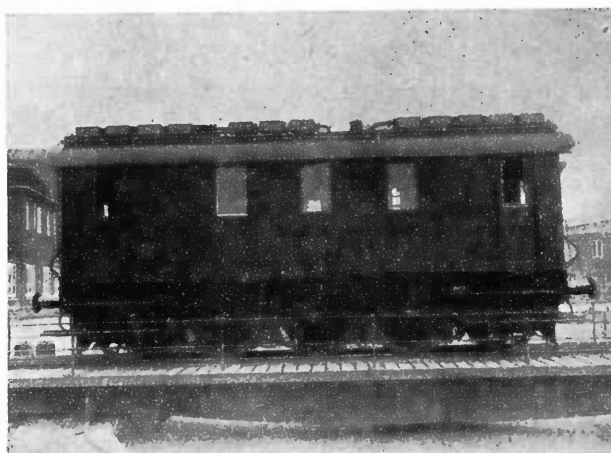

Skagensbanen SB, M4, 1935

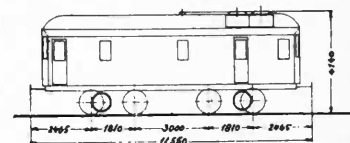

Hads-Ning Herreds Jernb. M1, 1926

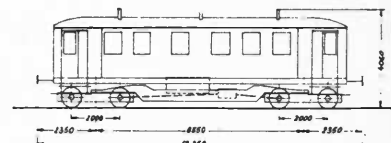

Trolldhede-Kolding-Vejen Jernbane,  
TKVJ, M1, 1926

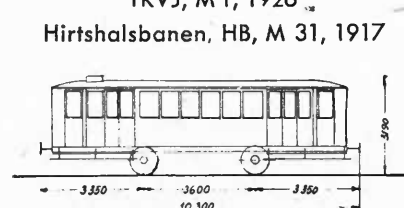

Hirtshalsbanen, HB, M 31, 1917

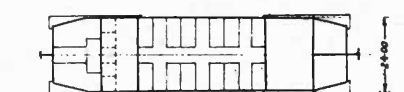

Sønderborg Amtsbanner, SAJ, M 1-2,  
1925

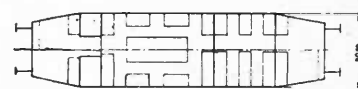

Maribo-Torrig Jb. M 2-3

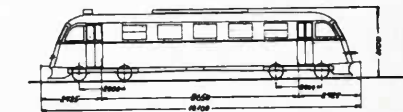

Diesel-skinnebus



DSB vogne

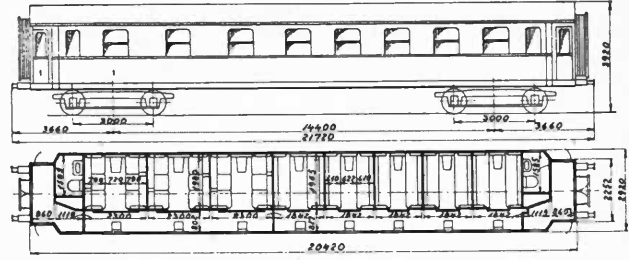

litra AV

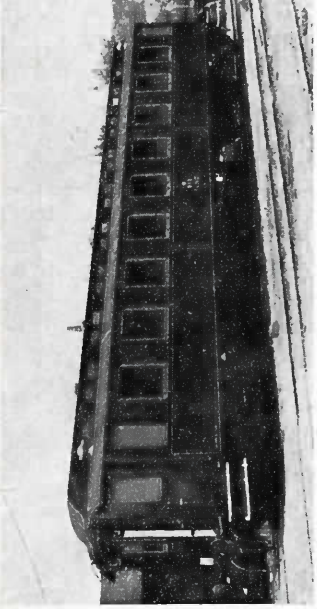

litra CM

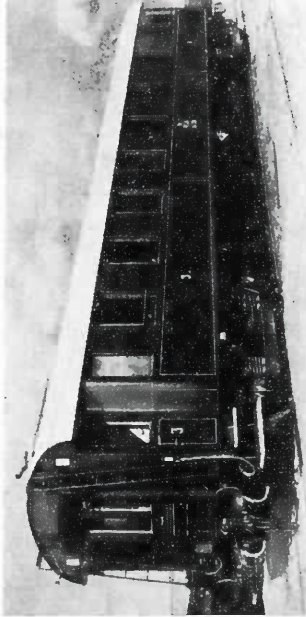

litra AU

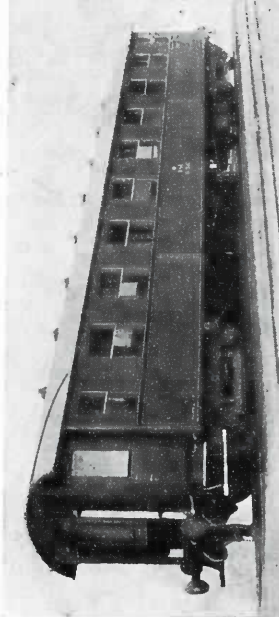

litra CO

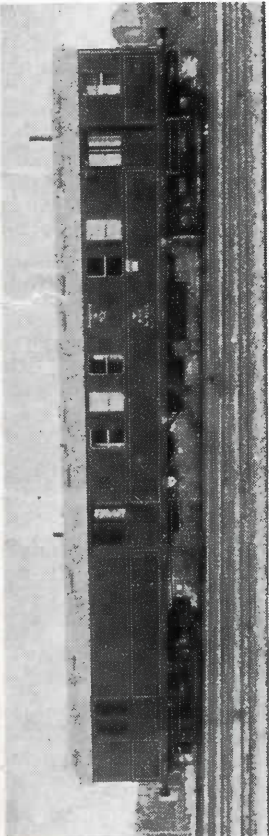
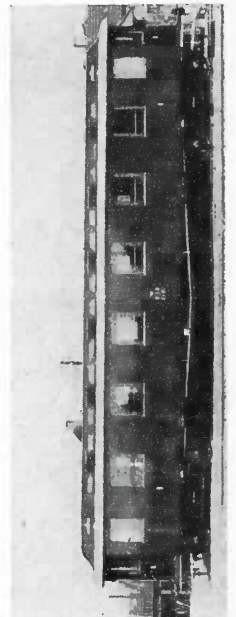

litra DC, Postvogn

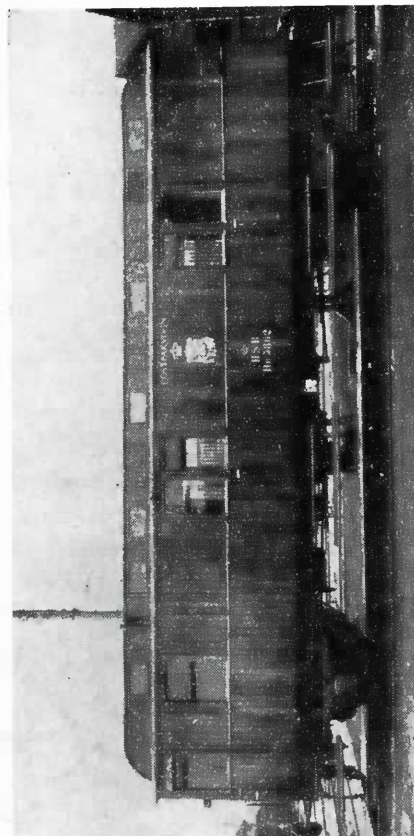

litra DR, Postvogn

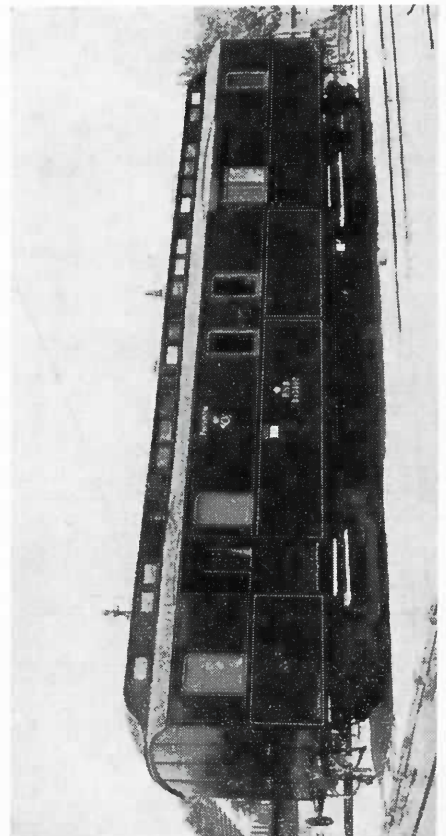

litra DJ, Postvogn

# Bogietyper

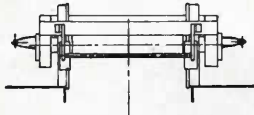
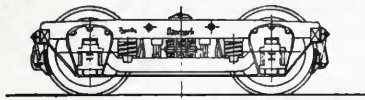

2,5 m træbogie

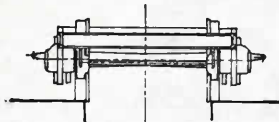
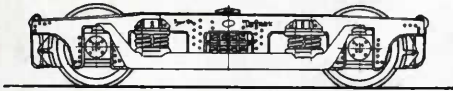

3,0 m niftet stål bogie

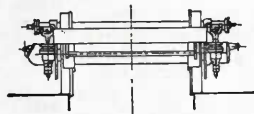
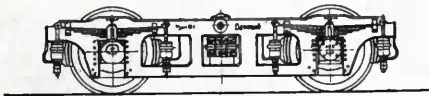

2,5 m jernbogie, Berlinertruck

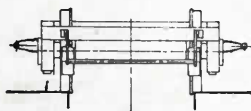
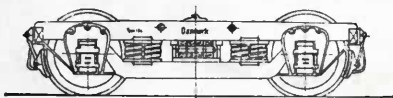

2,1 m træbogie

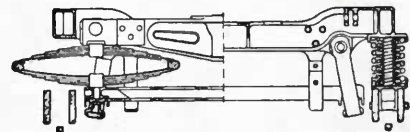
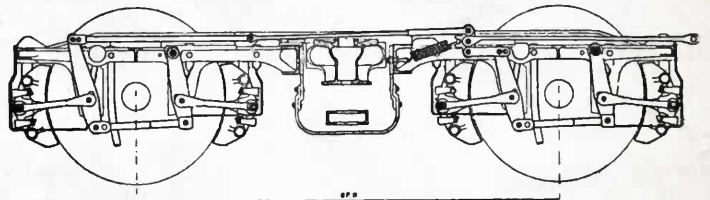
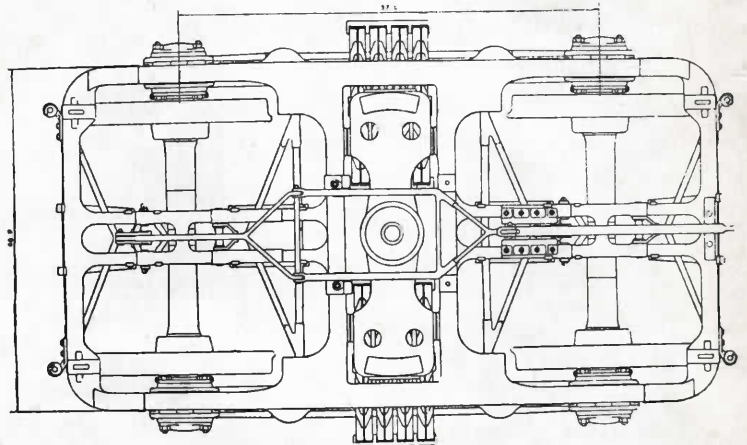
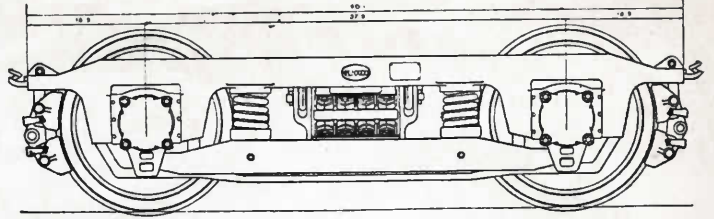

Serie 3300, Wagon lits. Størrelse 1/45

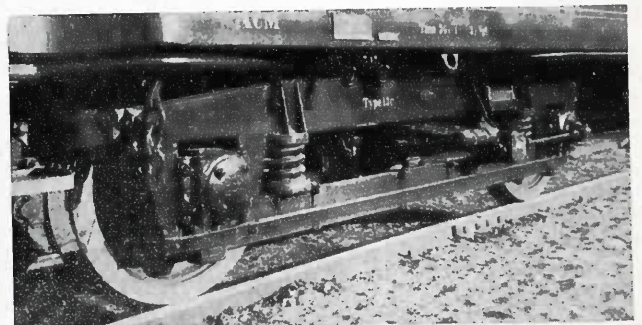

DSBs  
3-vogns lyntog  
dieselektriske  
motortog  
litra MS-AA-MS



Foto af modellen i størrelse 0, 1/45

22908 til Svartfyn paa A0



Målestok 1/87, spor H0

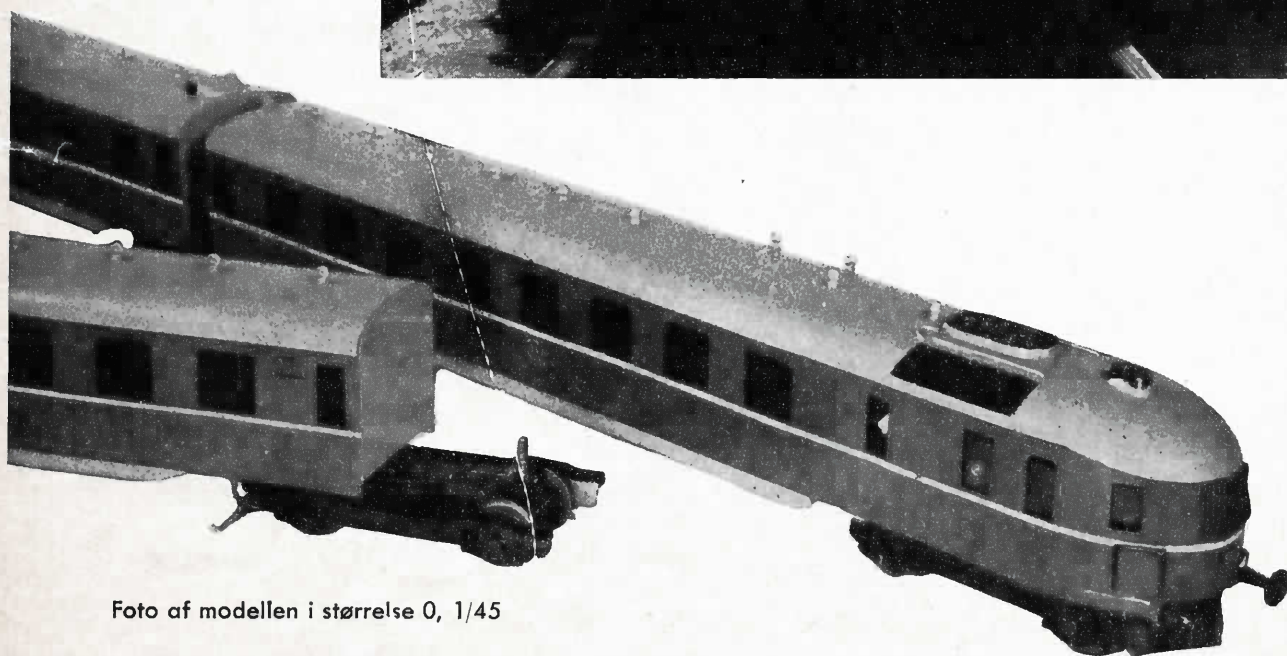
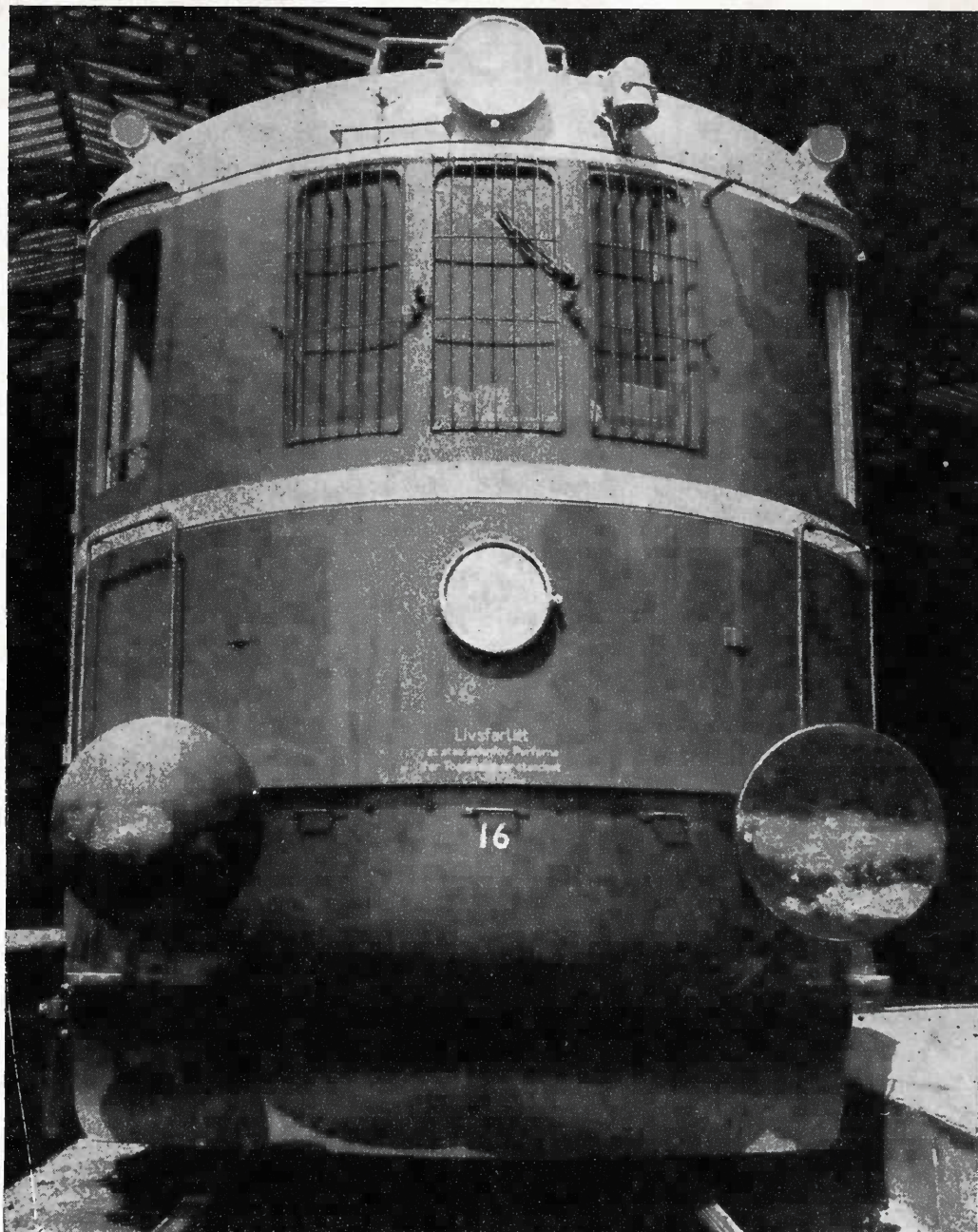
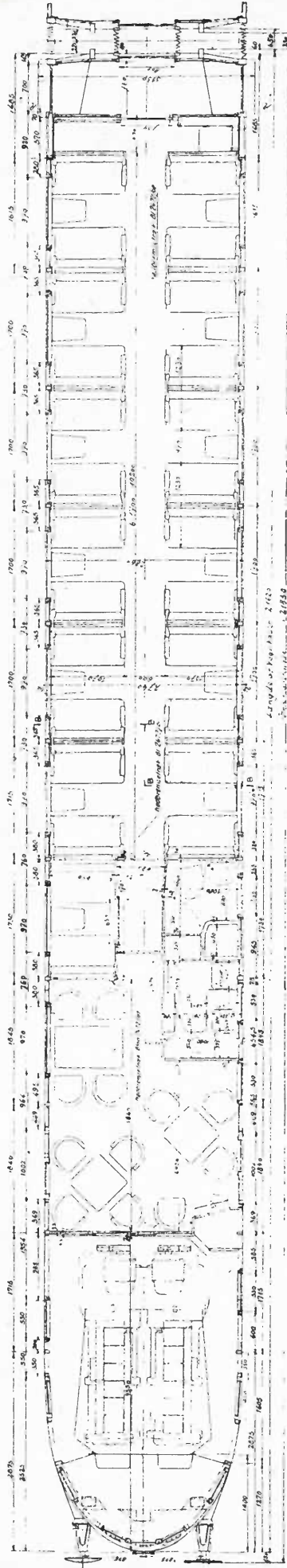
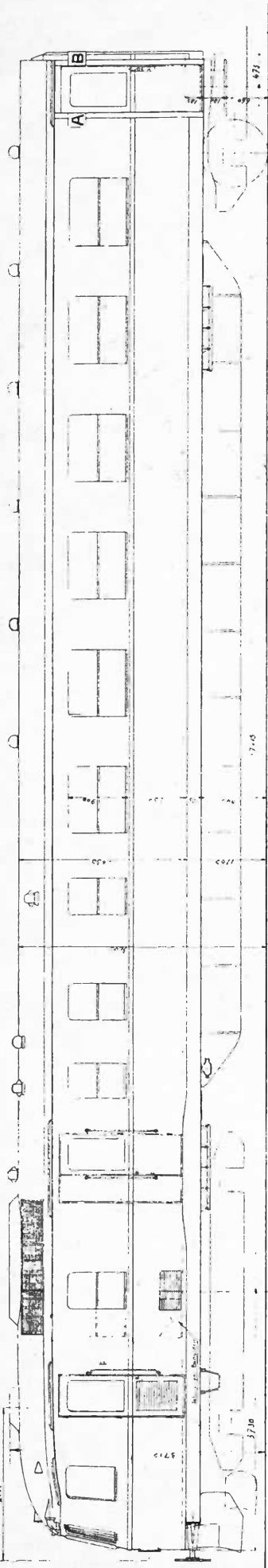
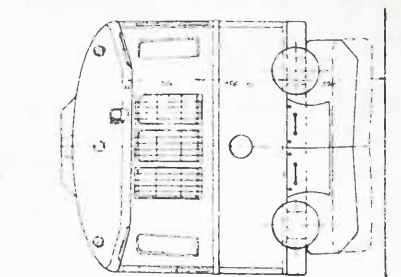
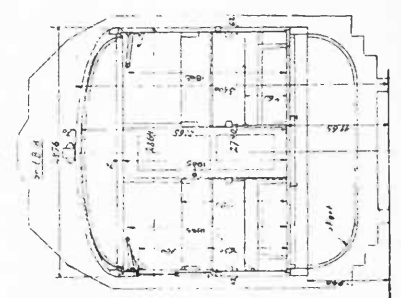
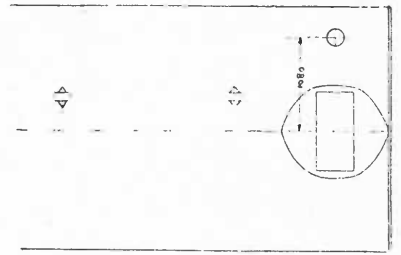

22908 til Svartfyn paa A0

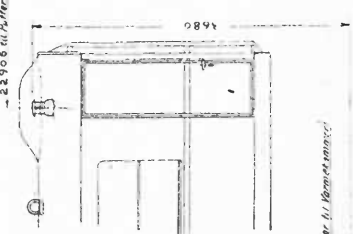

Op. til Svartfyn paa A0

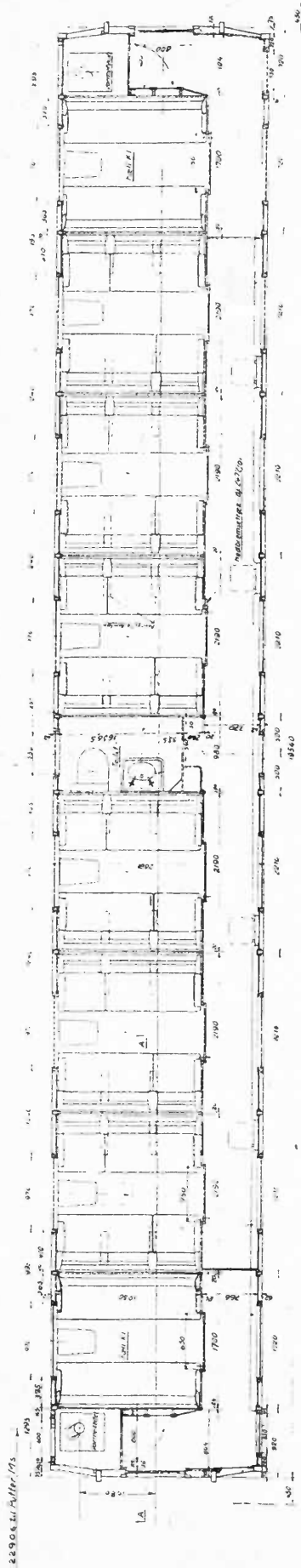
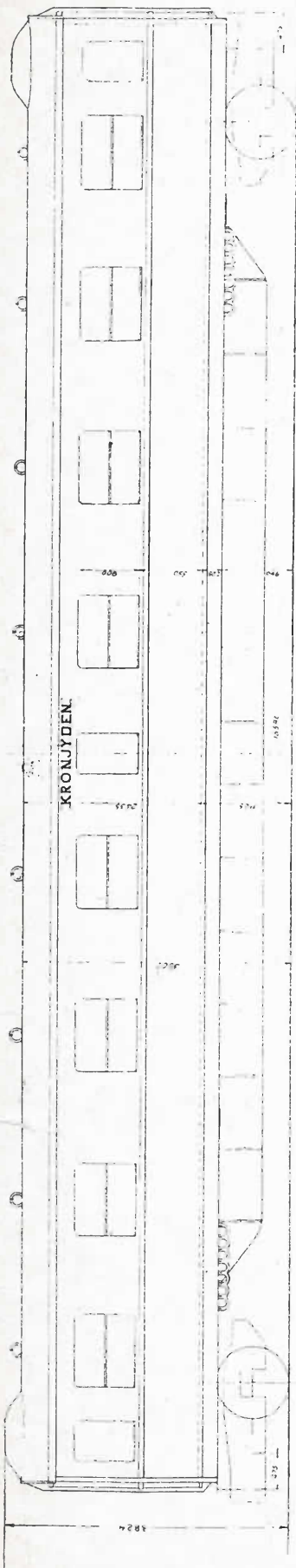

Motorbogje

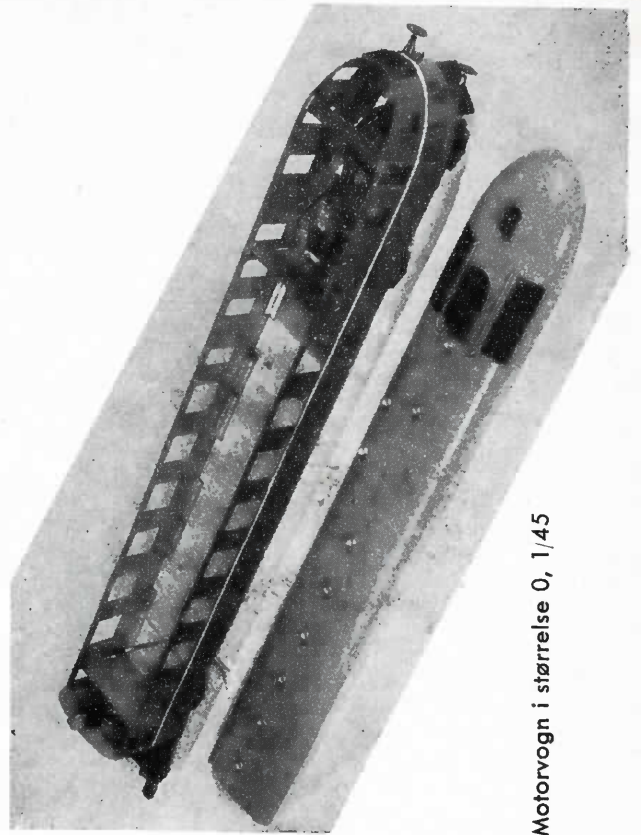
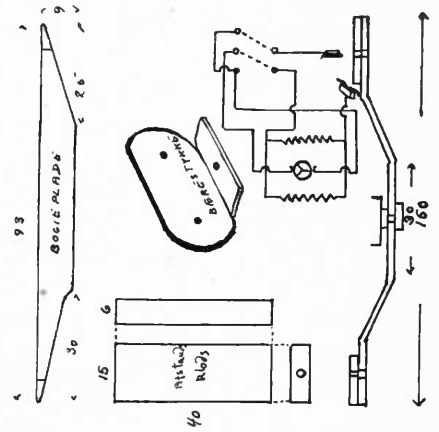
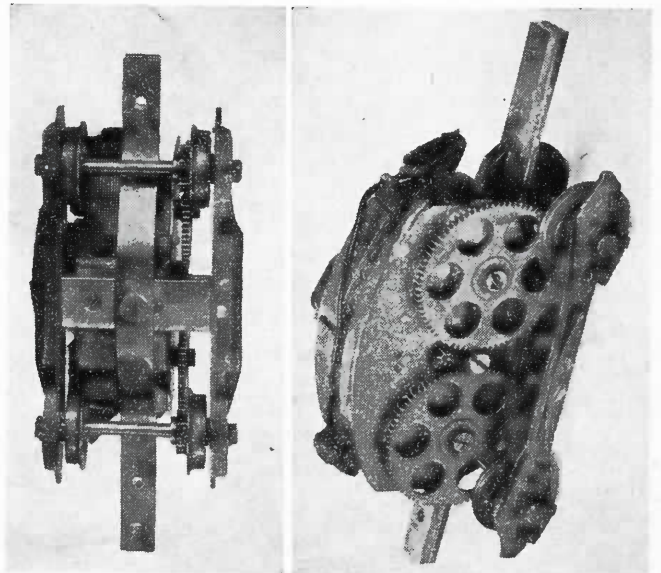

Motorvogn i størrelse 0, 1/45

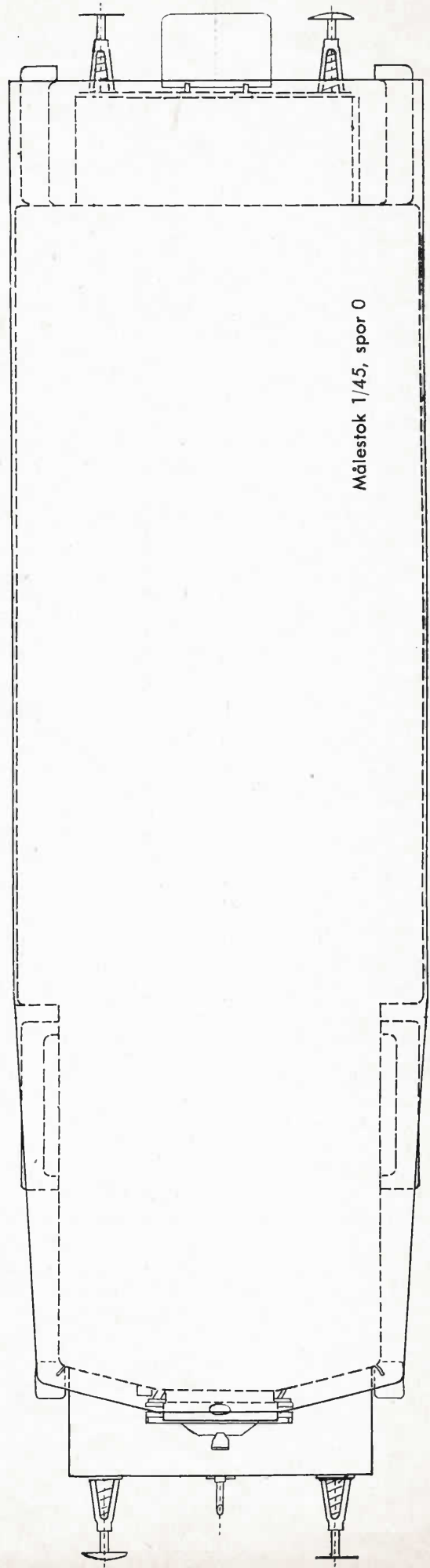
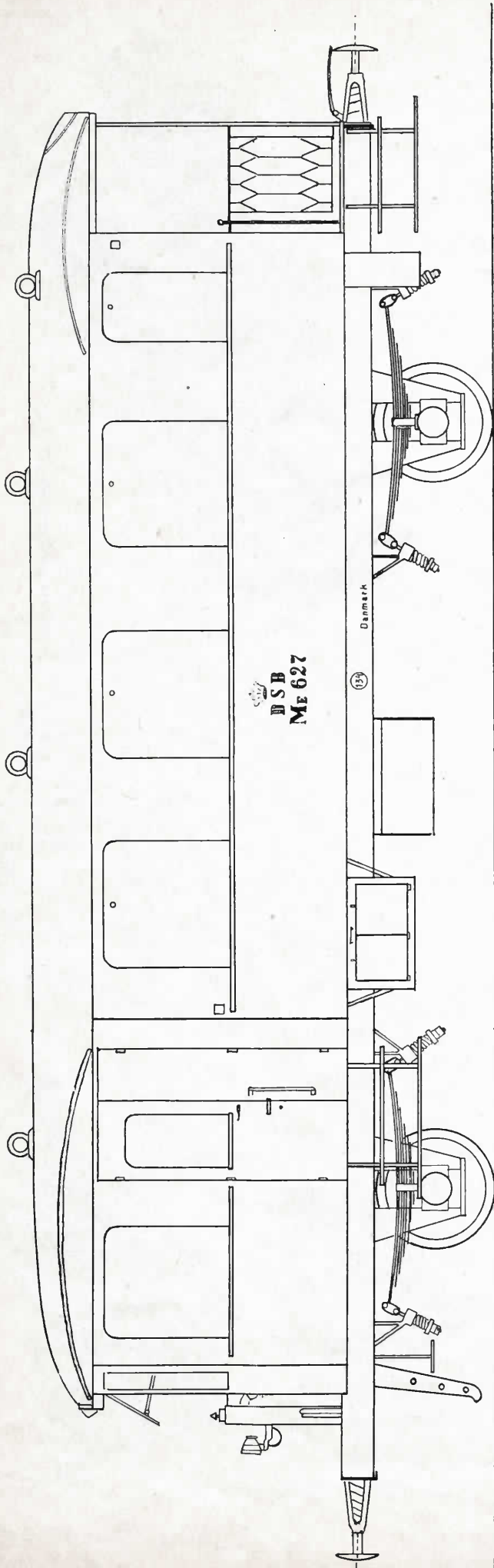

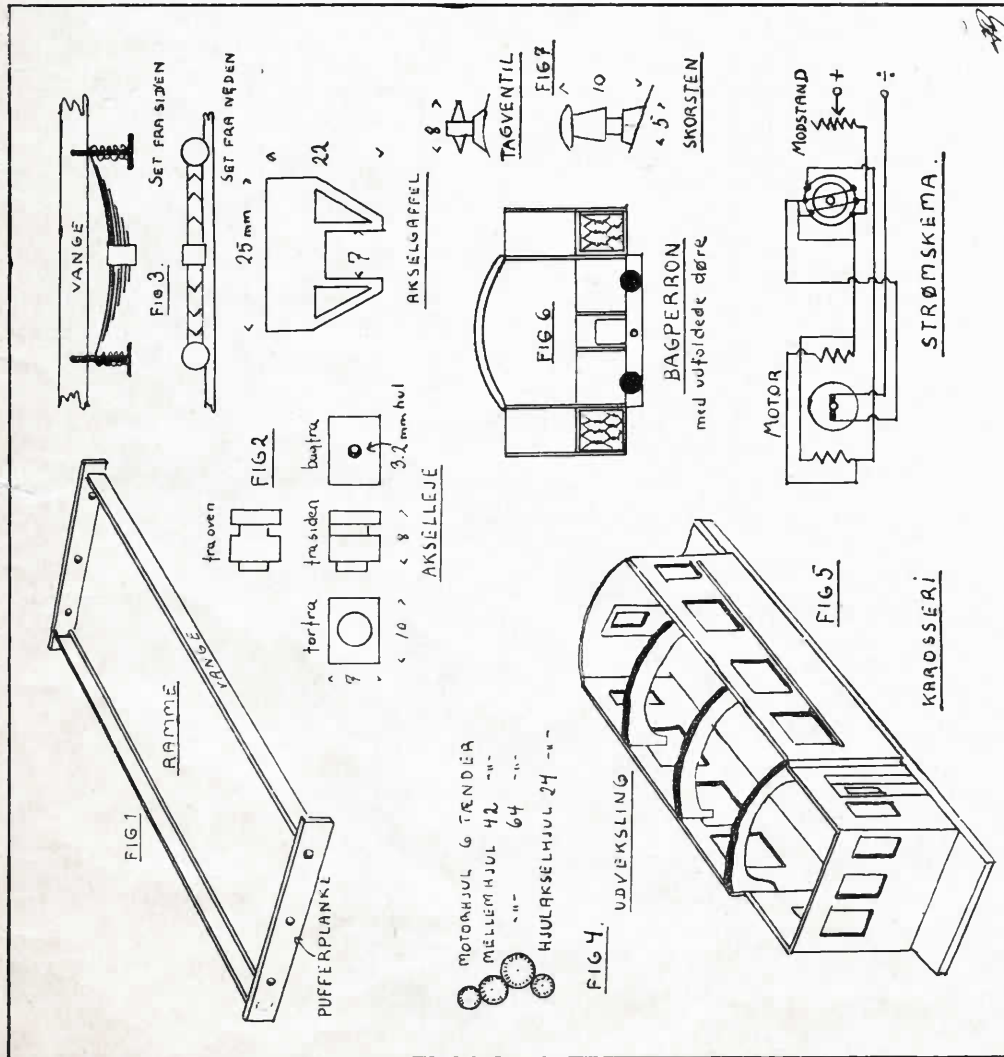

Detailtegninger

DSBs benzin-mekaniske motorvogn litra ME

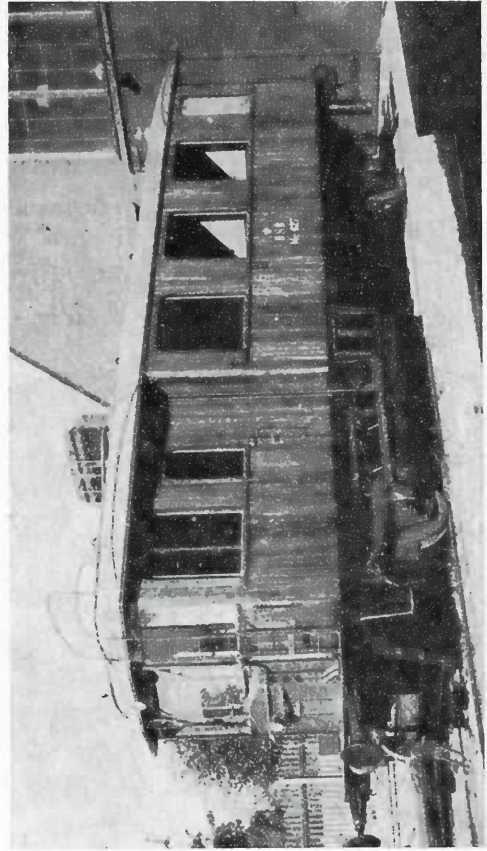
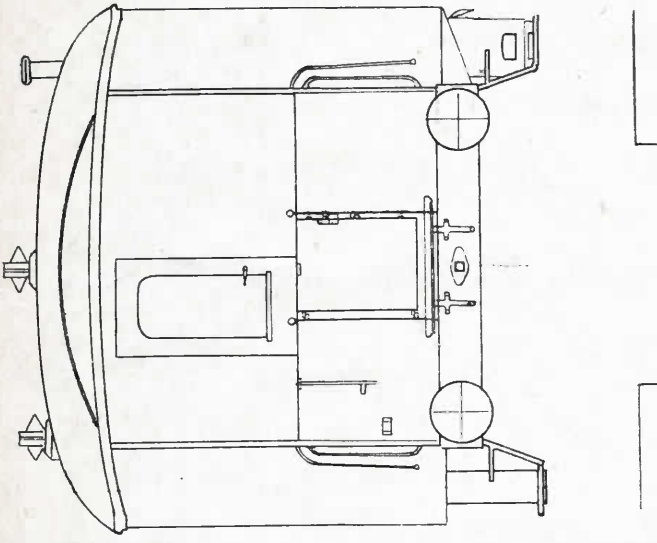

DSB litra ME 627 Foto udlånt af DSB





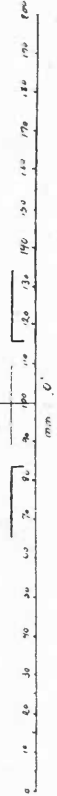
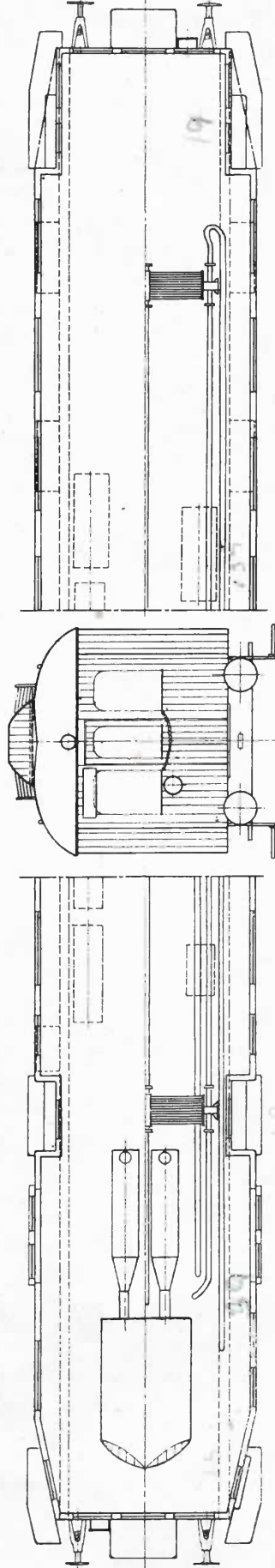
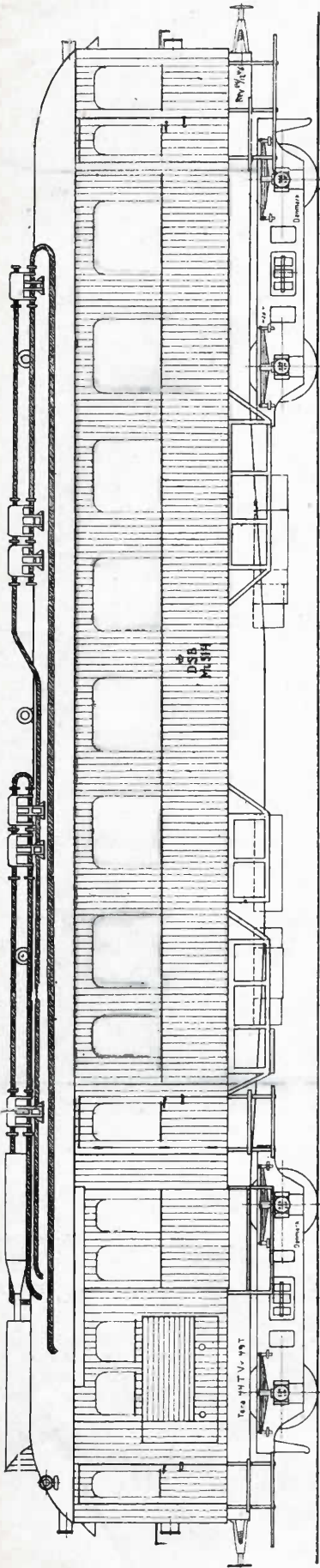

Litra ML 514

## Danske Statsbaners Litra ML dielelektrisk motorvogn

Nr. 501-515

bygget 1929-30 i Odense

Nr. 514 ombygget 1948 i Aarhus

2 dieselmotorer

Trykløftbremse (P)

Vægtfangsbremse

Dynamoanlæg

Varmtvandsanlæg

Vandkloset

70 siddepladser, fællesklasse

Tara ca. 44.000 kg

Last i rejsegodsrum 1760 kg

Maling:

Tag: lysegråt

Vognkasse: brun

Undervogn: sort

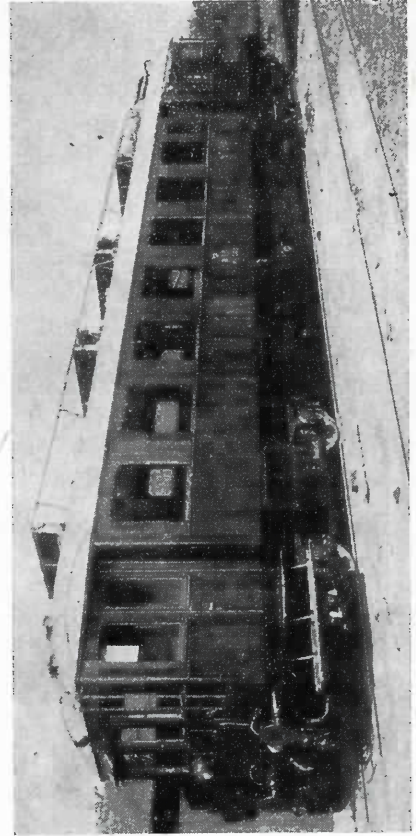

Litra ML 508







# Skinnebus

Målestok 1/87, spor H0



Foto af en SJ skinnebus



Motorvogn

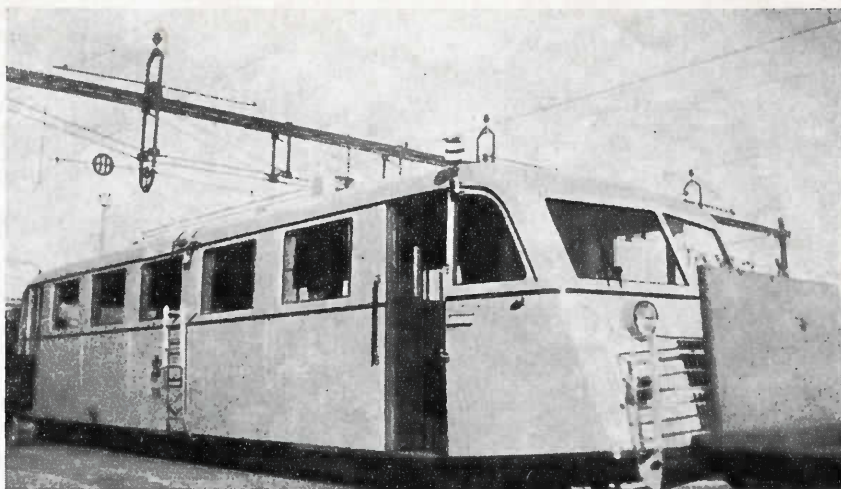
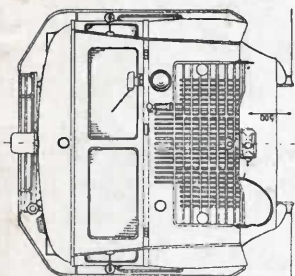
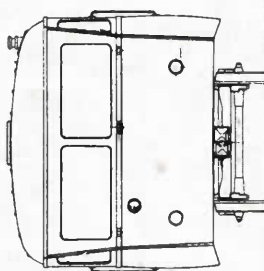
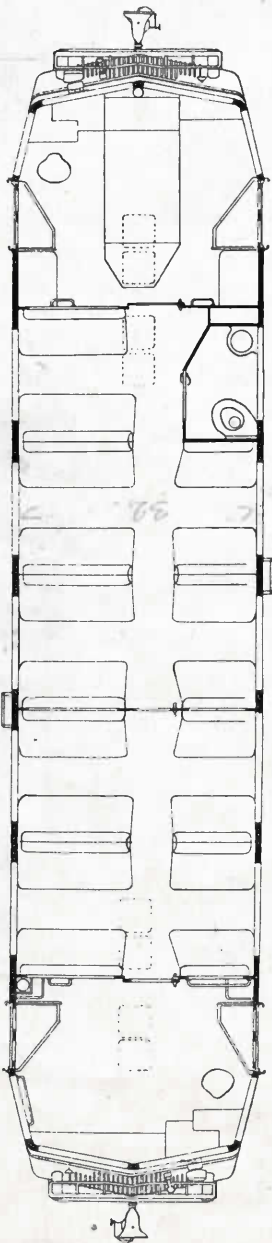
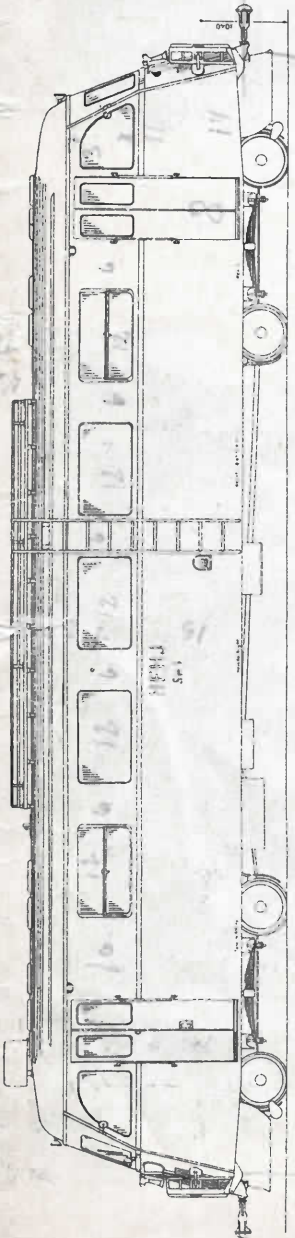

Bivogn

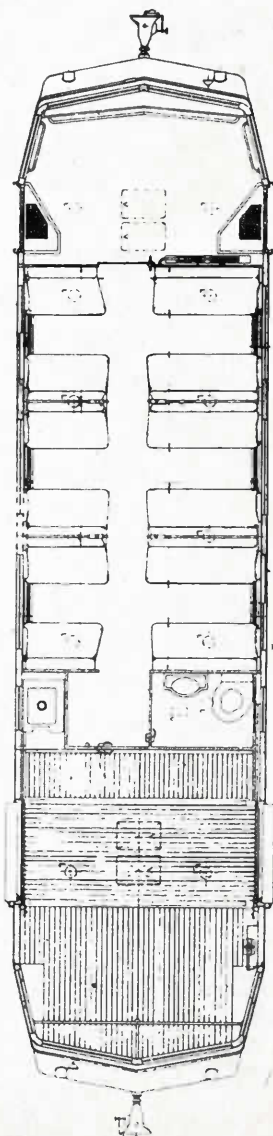
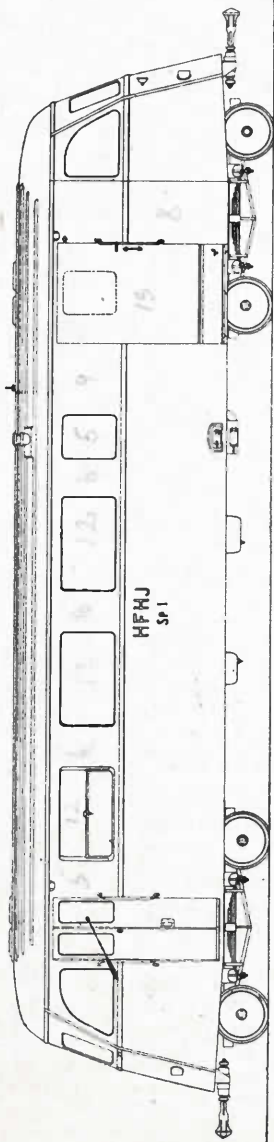

# DSB personvogn litra AC

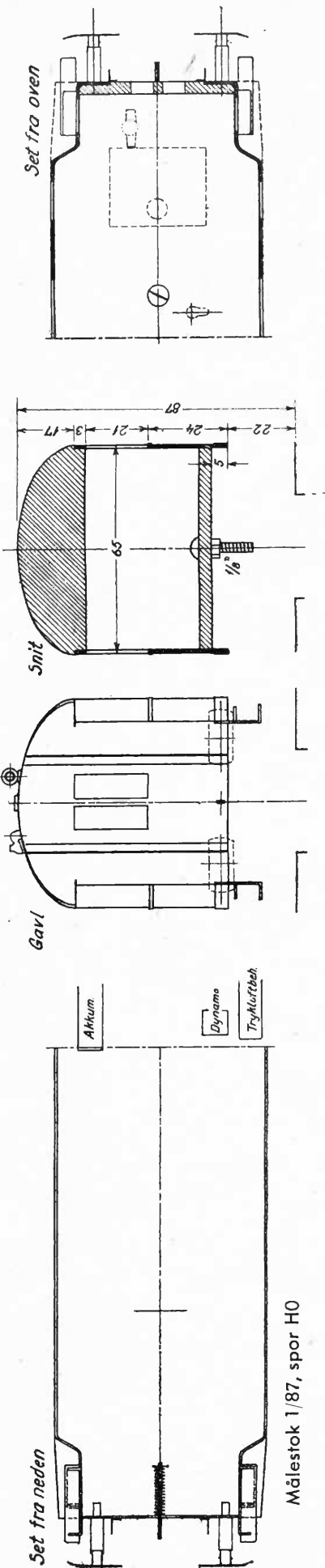
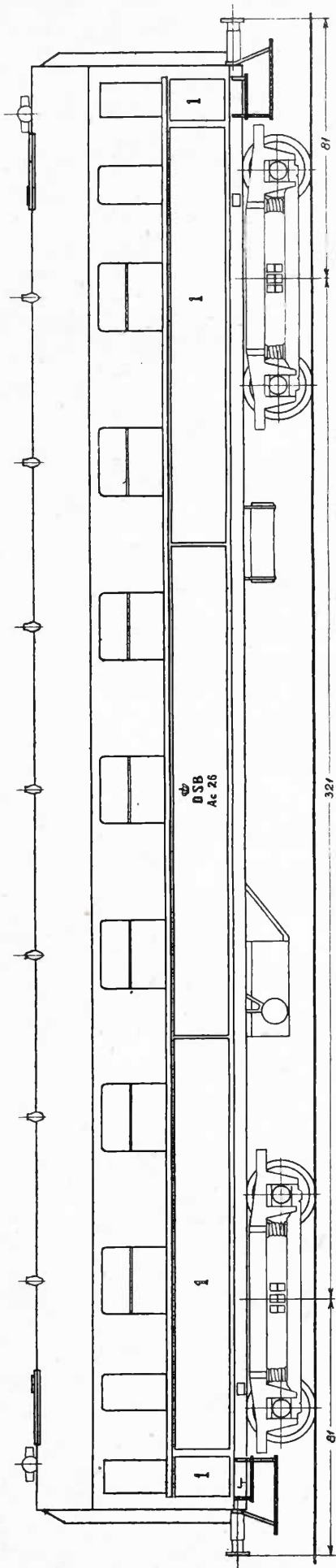

Målestok 1/87, spor H0



Foto af originalen, ny model (Nr. 37-42)



Foto af originalen, ældre model

# Detailfotos

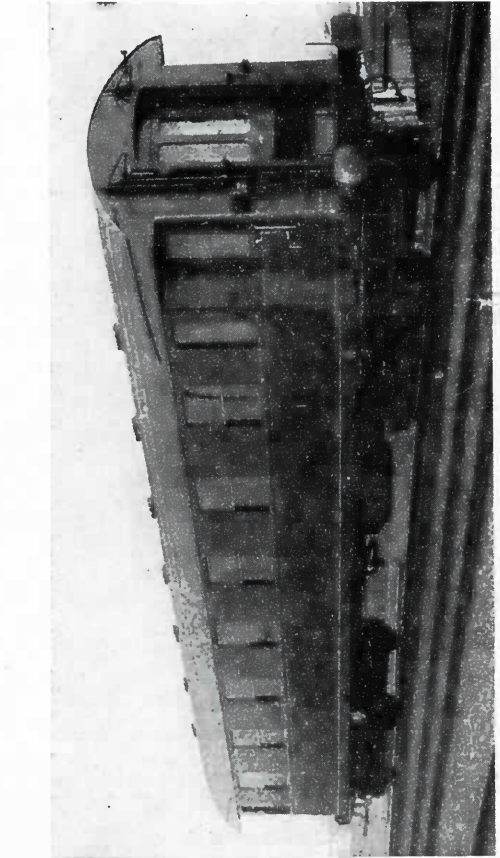

Model af AC 27, spor 0, 1/45

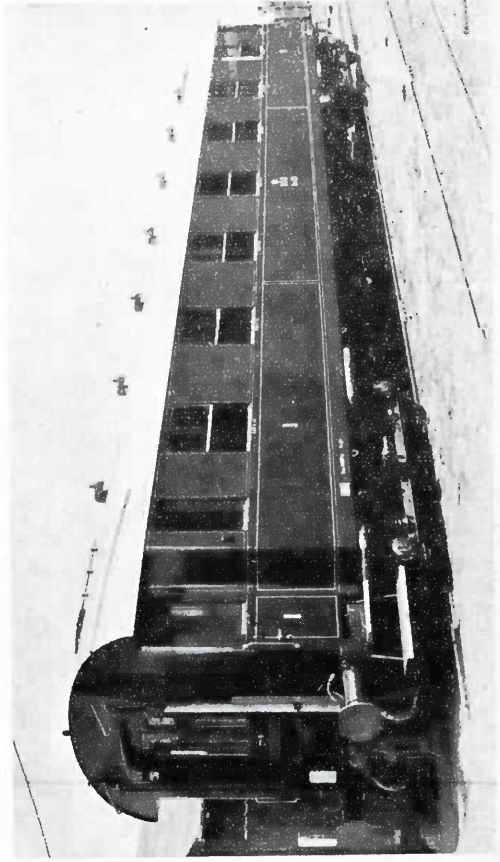
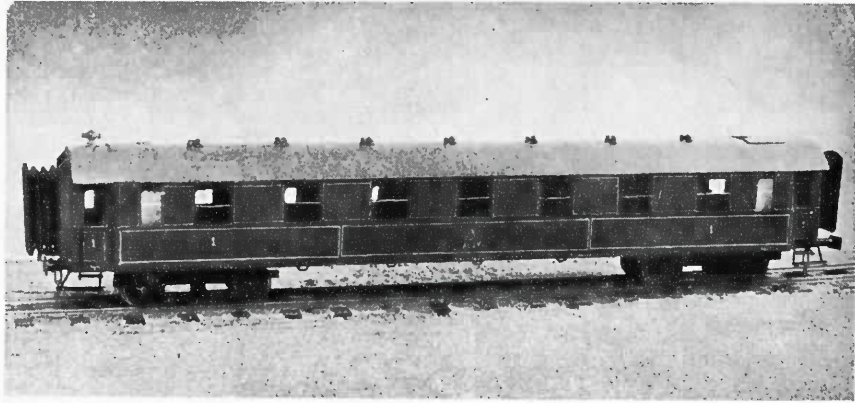
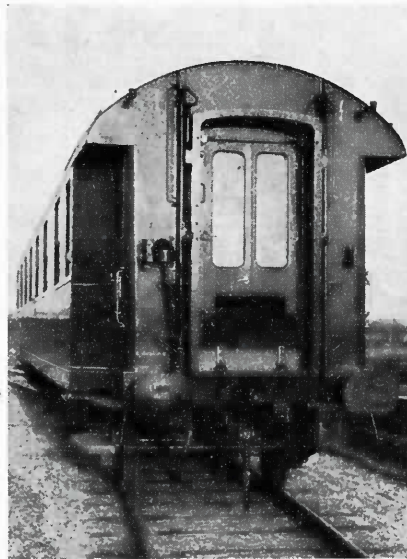

Gavl

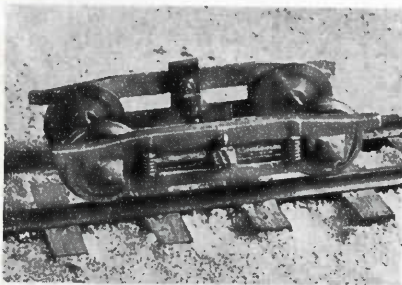

Bogien i 1/45

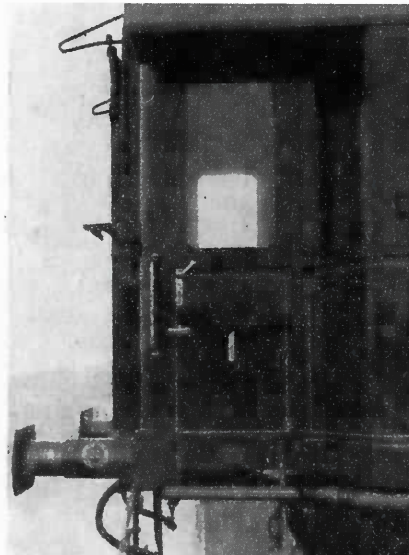

Dør







Foto af model i 1/45, spor 0



AF-vogn i målestok 1/45, spor 0

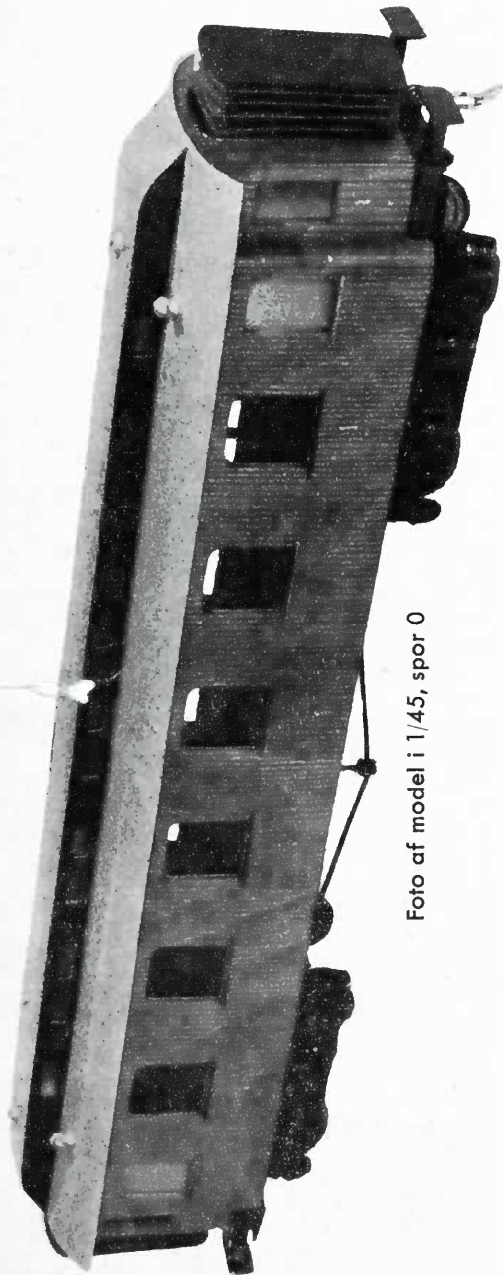
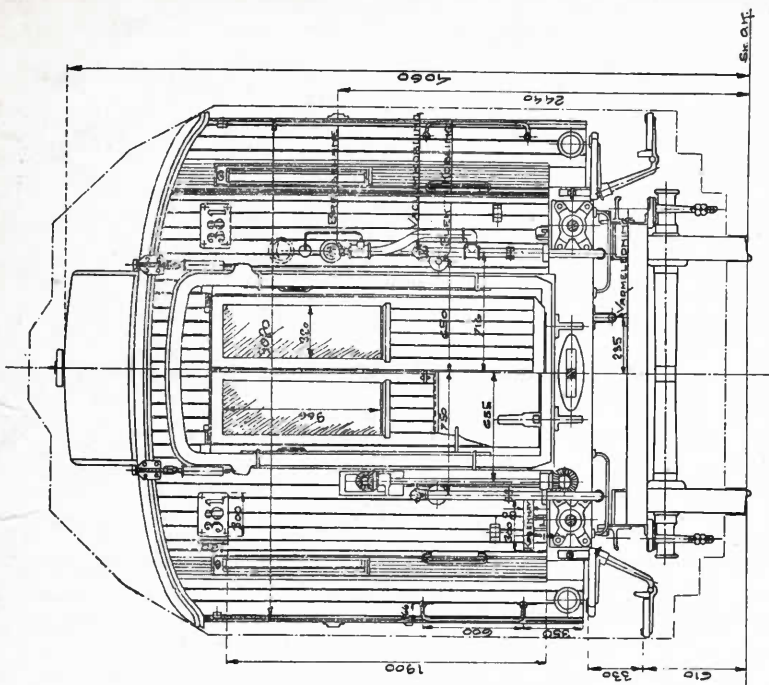

Foto af modellen

## Odsherreds Jernbanes to-akslede personvogn A 202

Målestok 1/87, spor H0

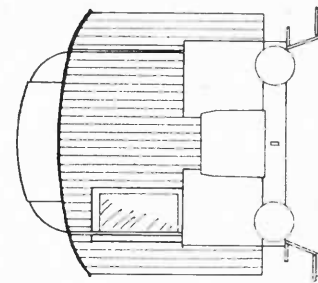
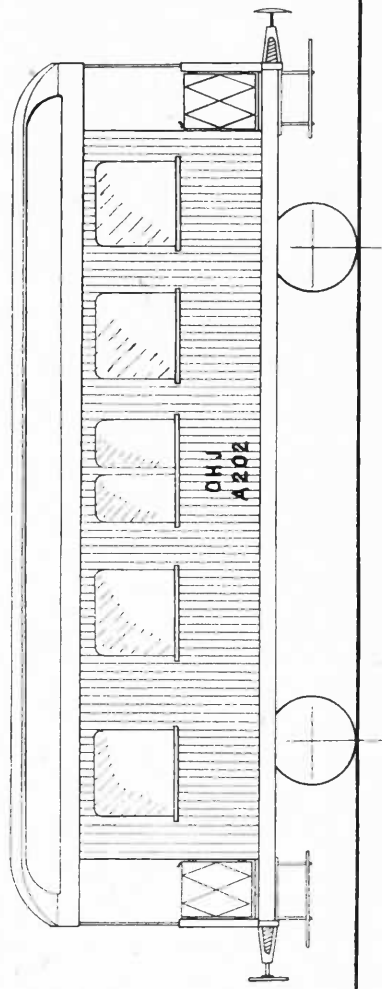

# DSBs postvogn litra DO

Målestok 1/45, spor 0

166

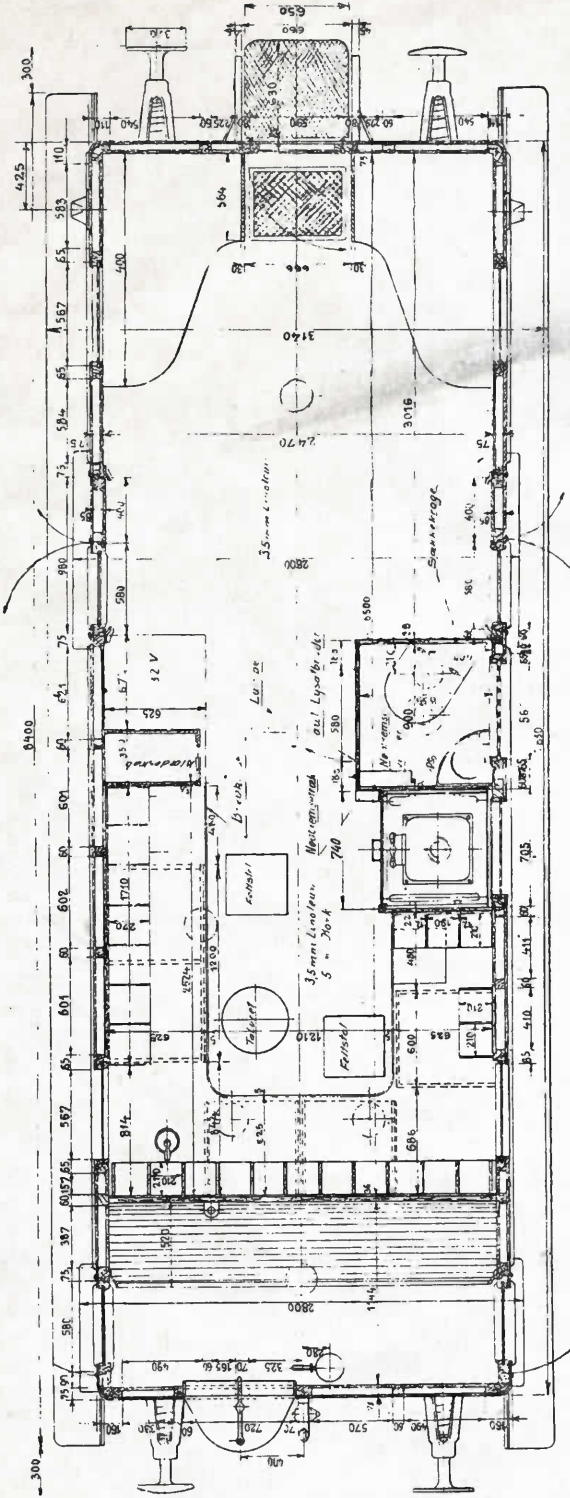

Indiker for vinduet

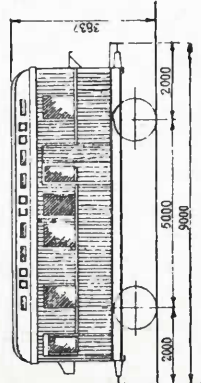
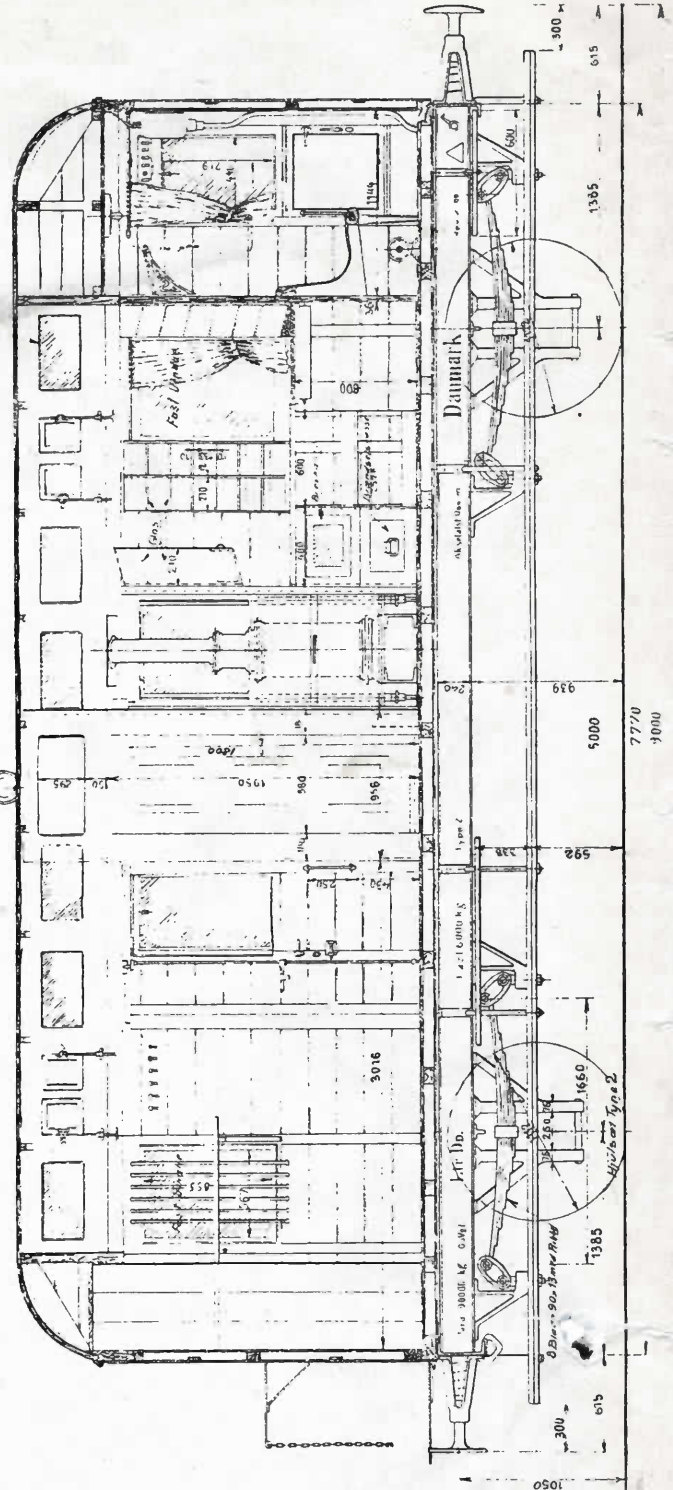

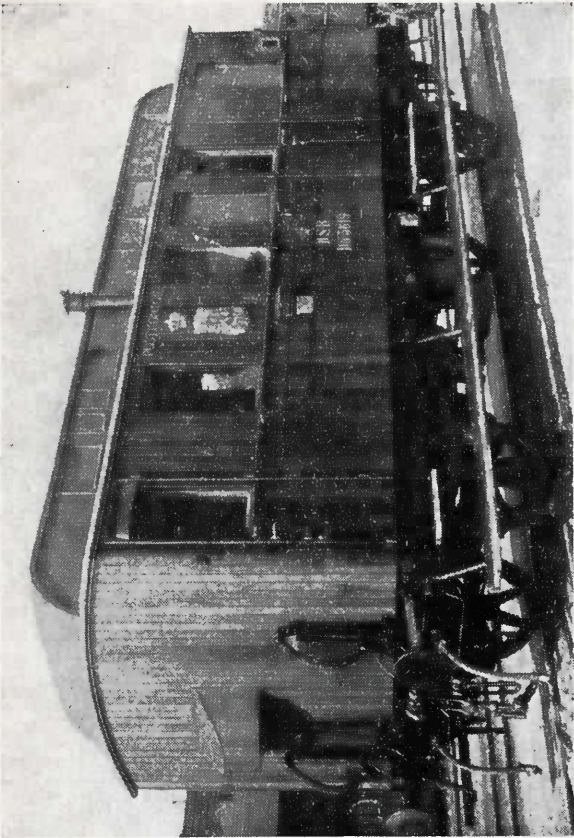

DSBs litra DO

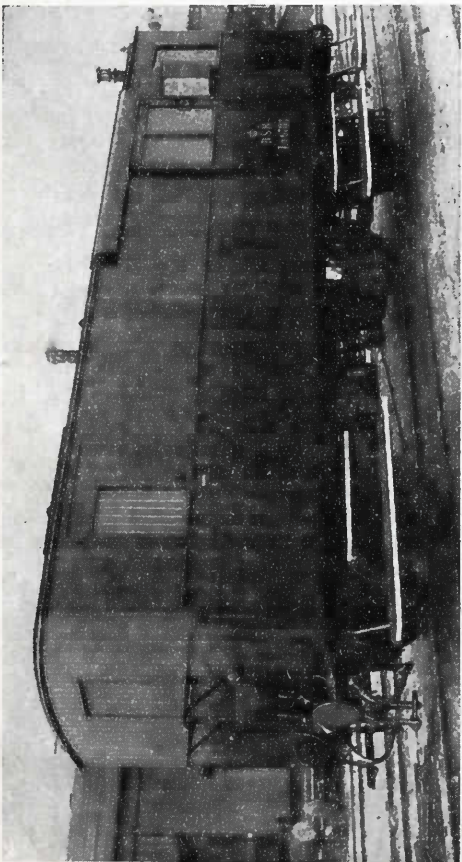
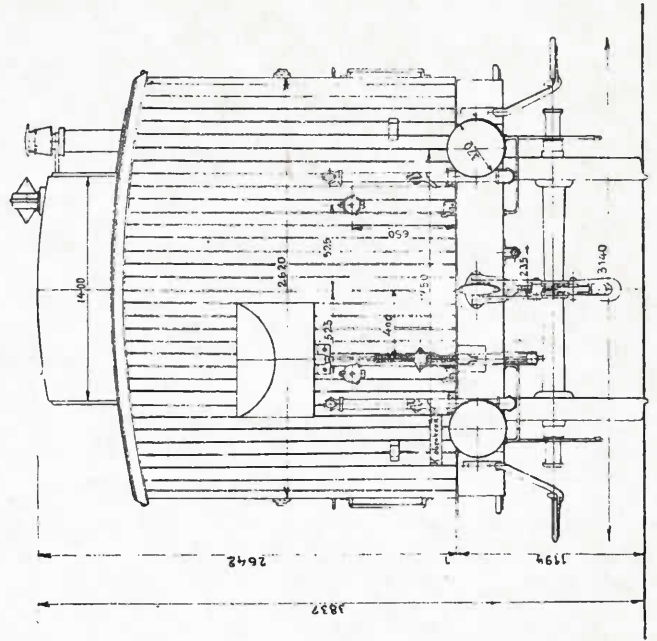

DSBs litra EH



Foto af EH-model i 1/45, spor 0

# DSBs rejsegodsvogn litra EH

Målestok 1/45, spor 0



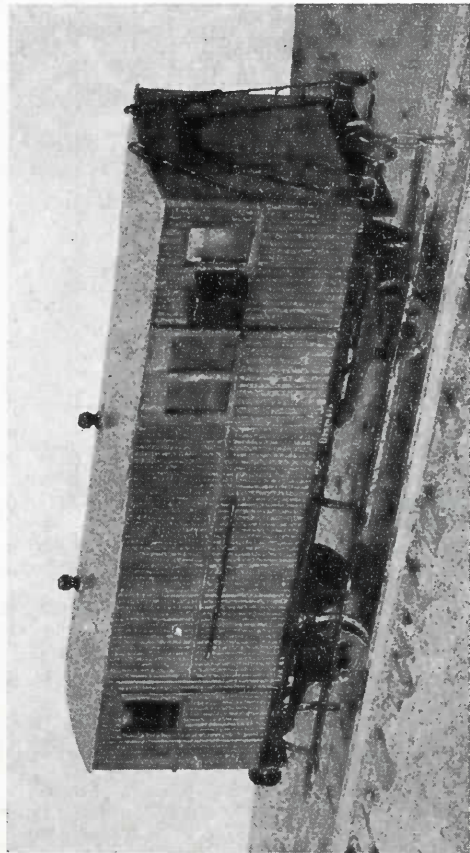
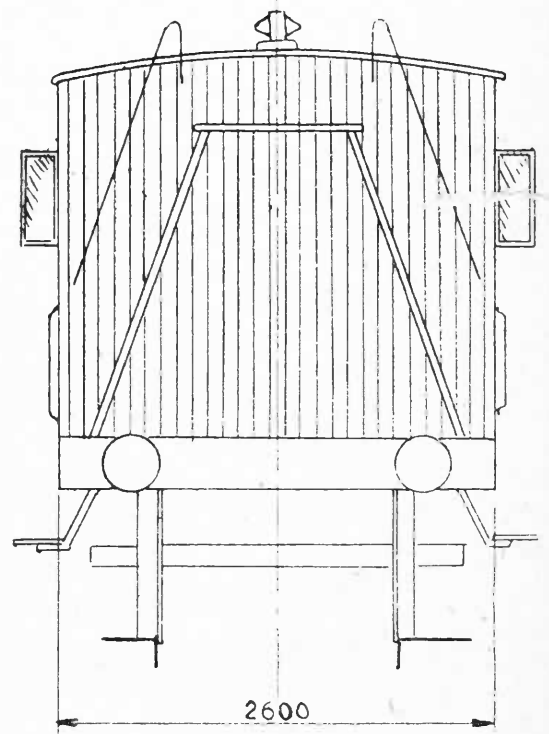
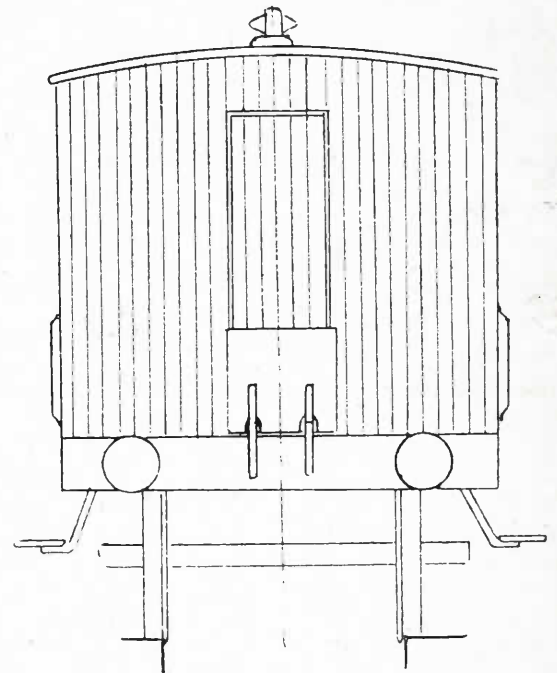
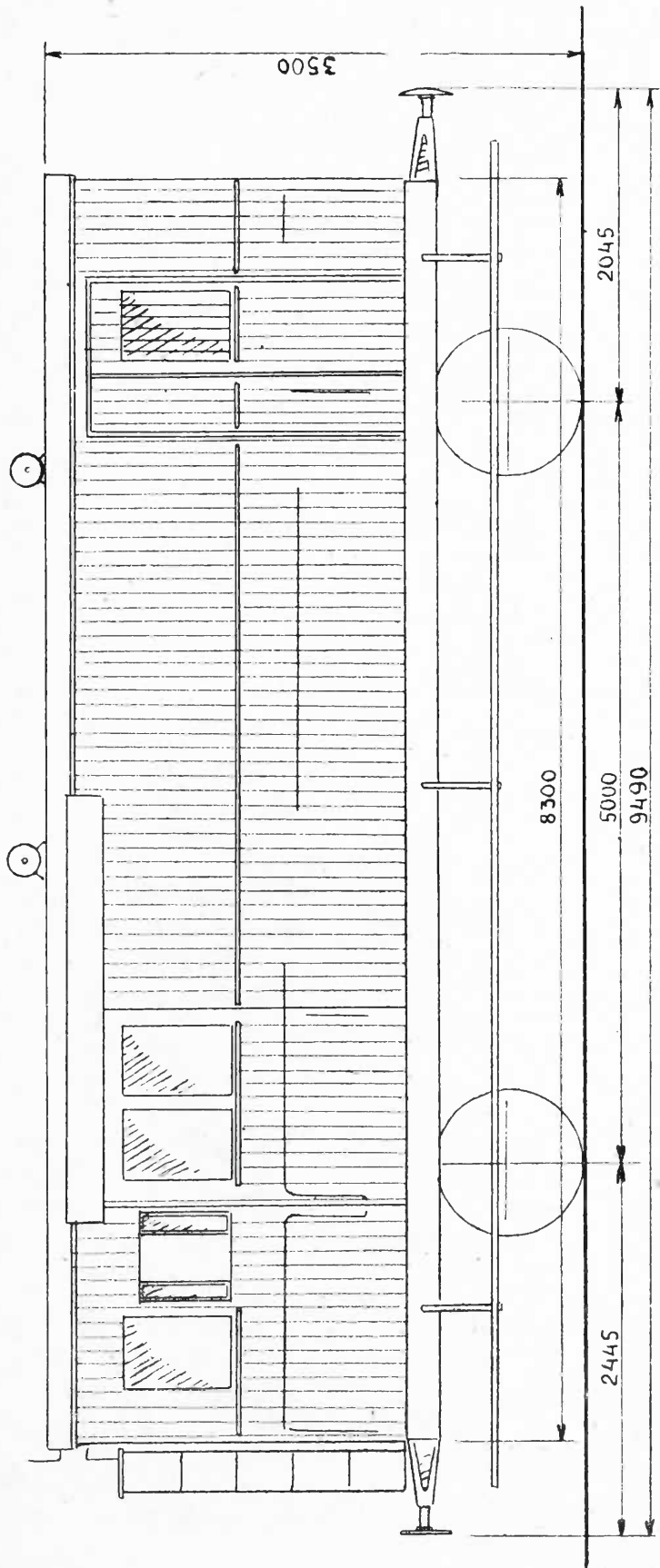
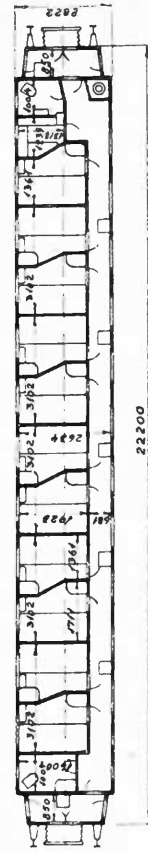
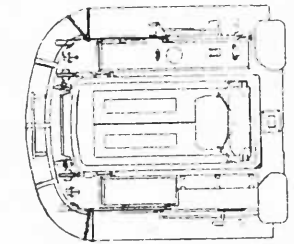
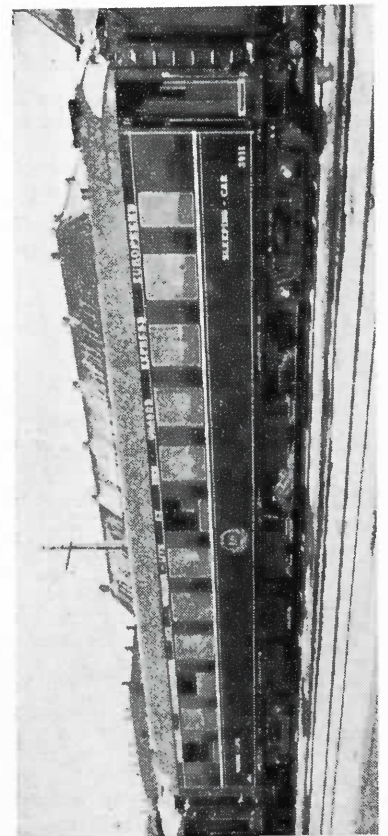
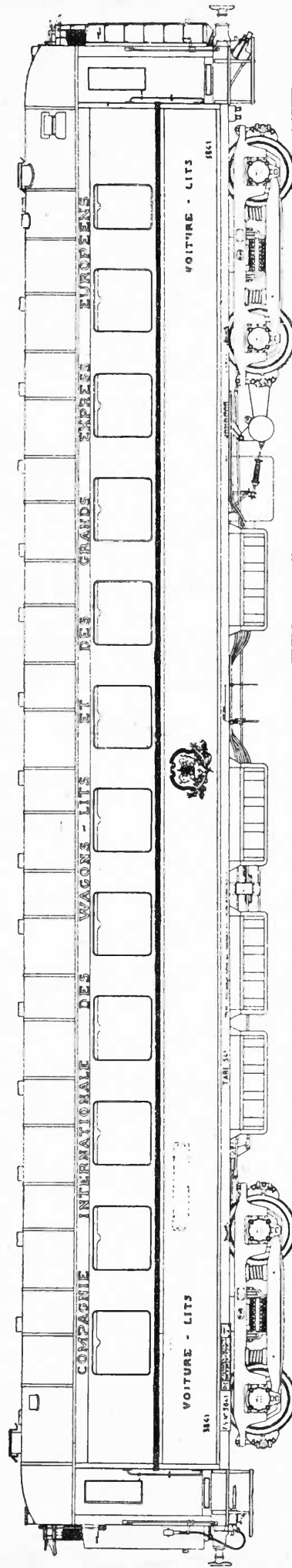
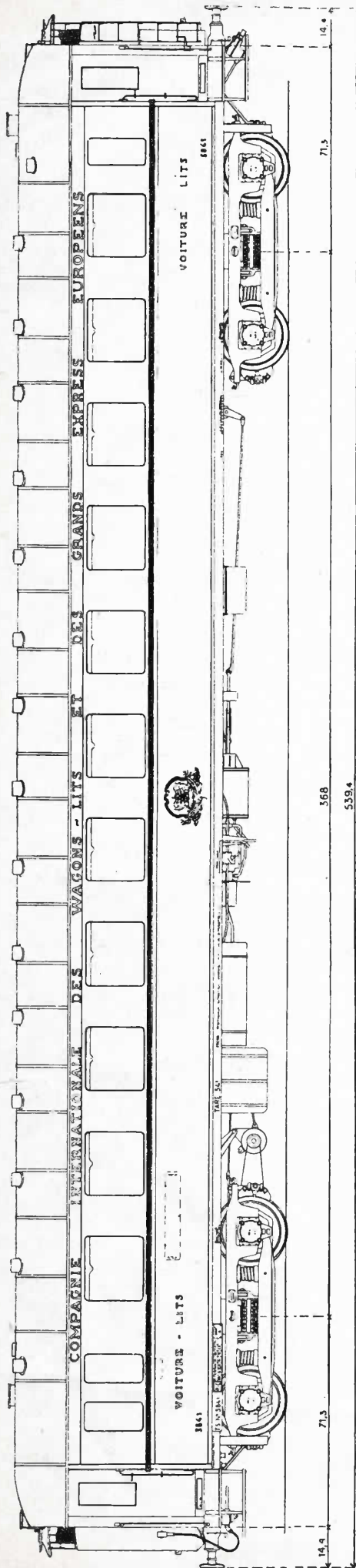

Det internationale Sovevogns Selskab:  
1. og 2. classes vogn. Sovevogne

Målestok 1/87, spor H0

# Det internationale Sovevogns Selskab Spisevogn

Målestok 1/87, spor H0

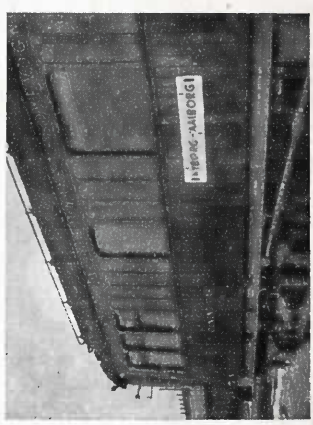
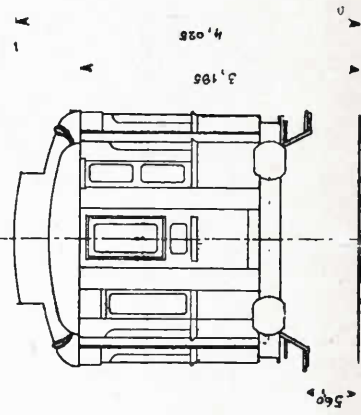
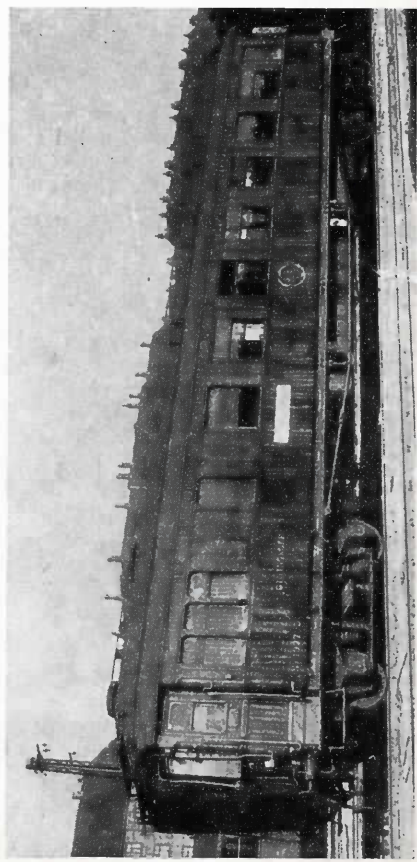
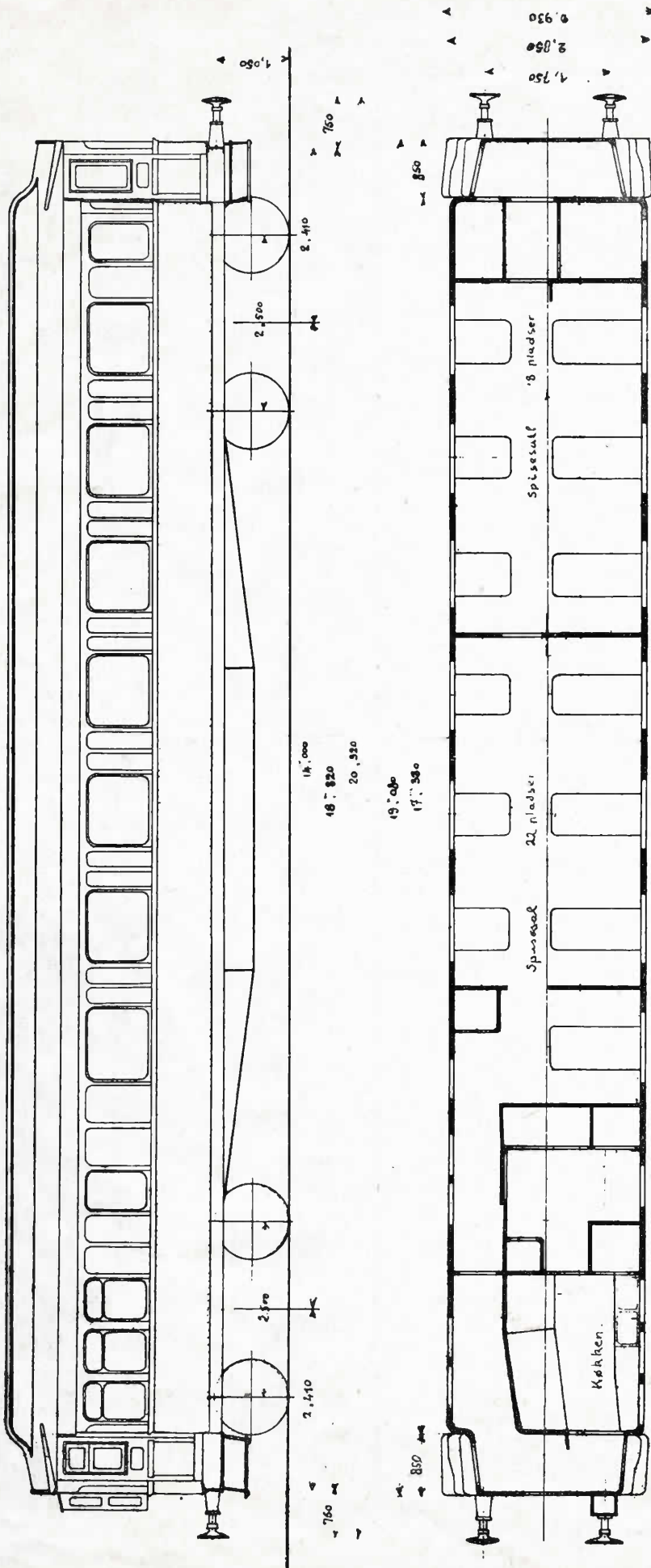

# DSB lukket godsvogn litra QH

Målestok 1/45, spor 0

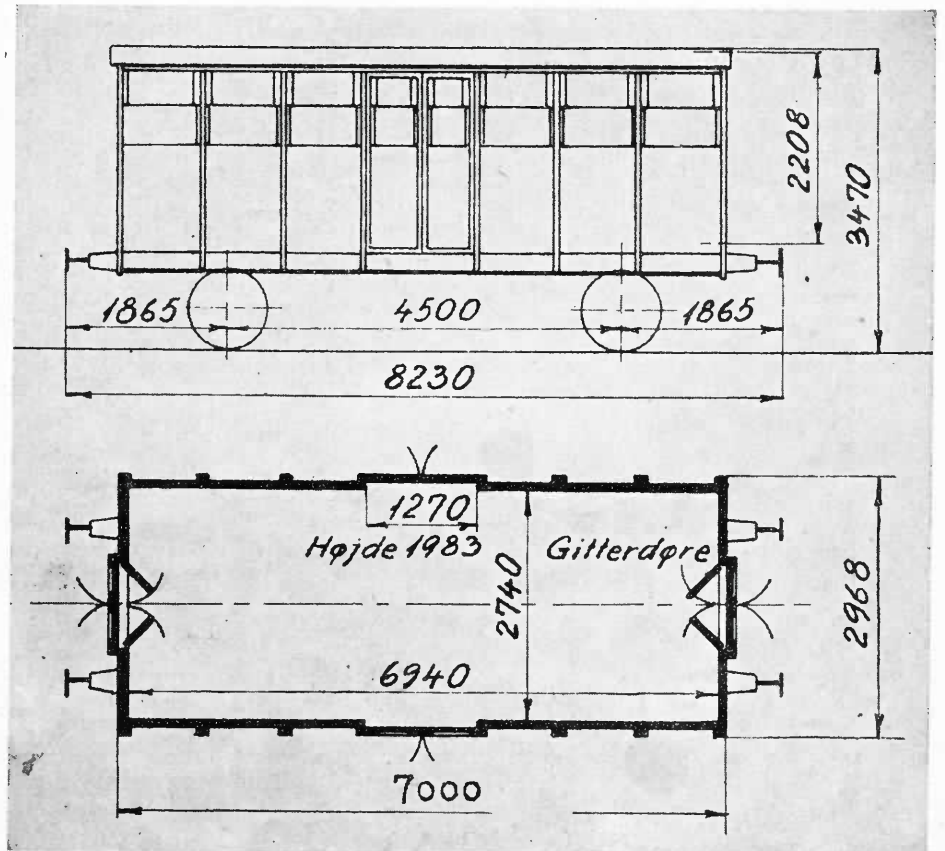
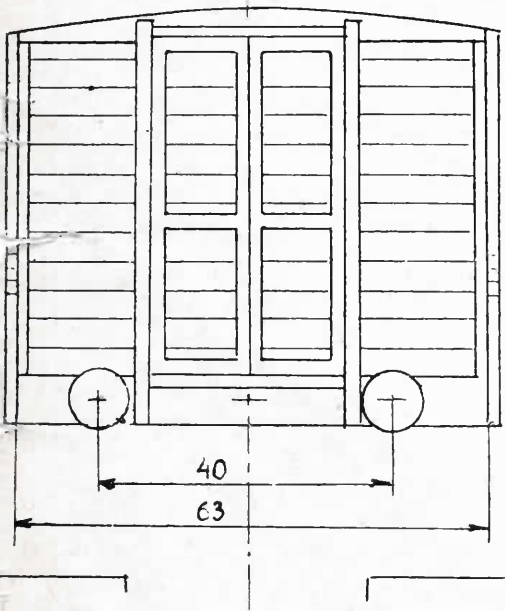
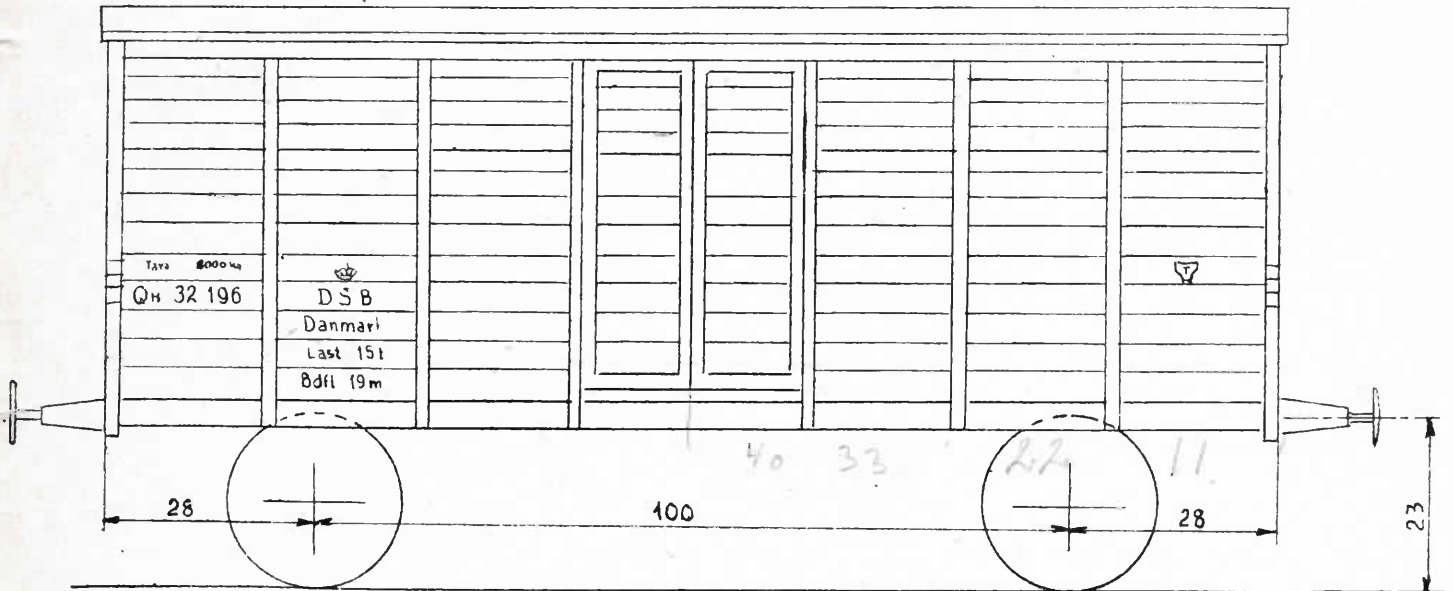
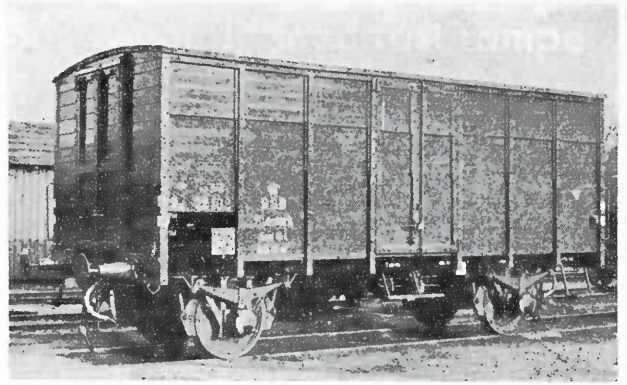

# DSB åben godsvogn litra PB

Målestok 1/47, spor H0

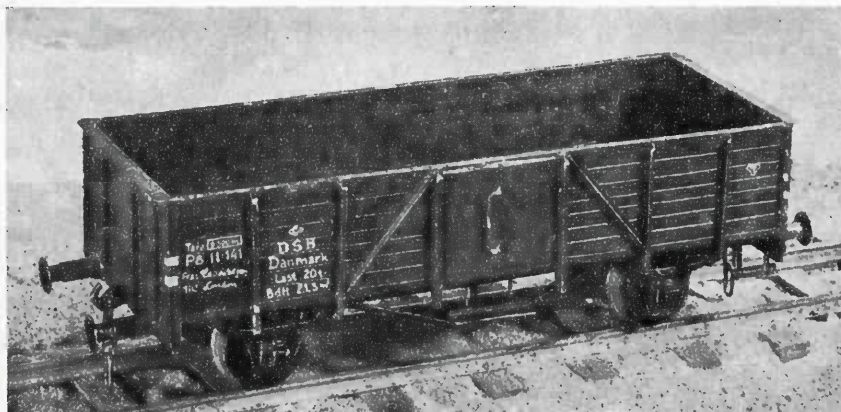
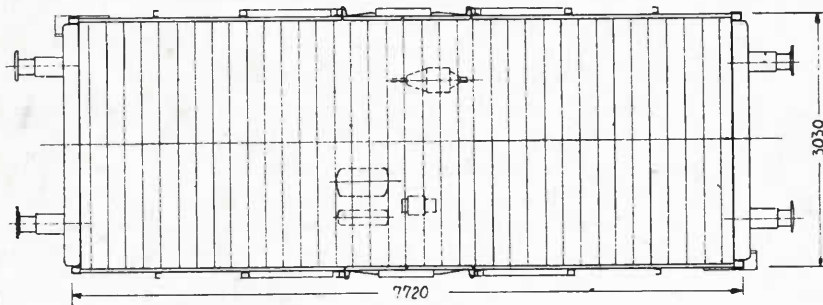
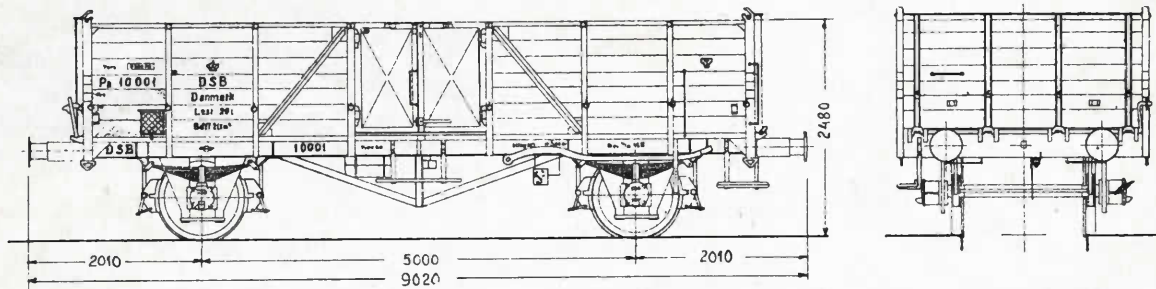



# DSB kølevogn litra IKS

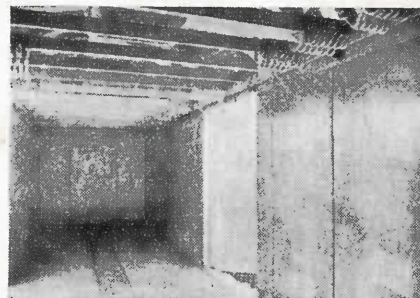
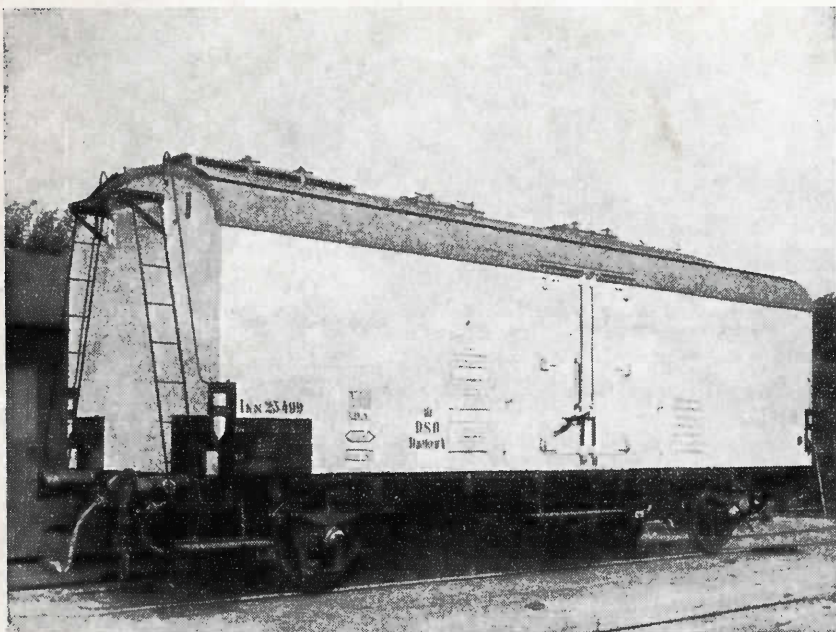

Det rustfri indre

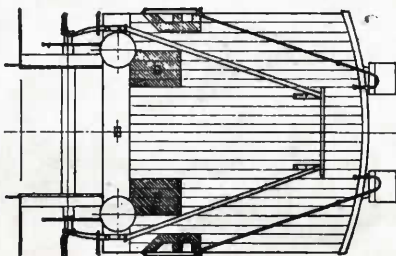
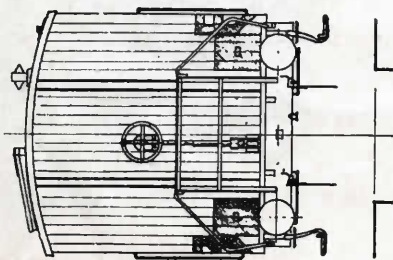
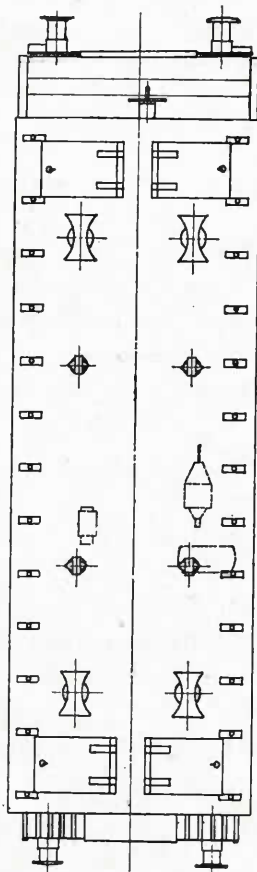
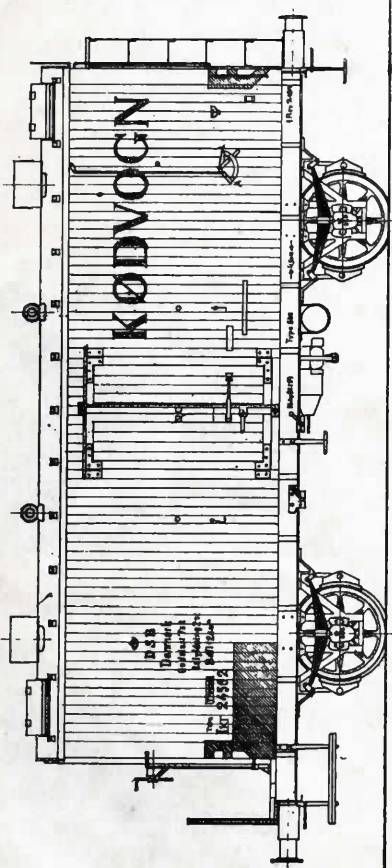
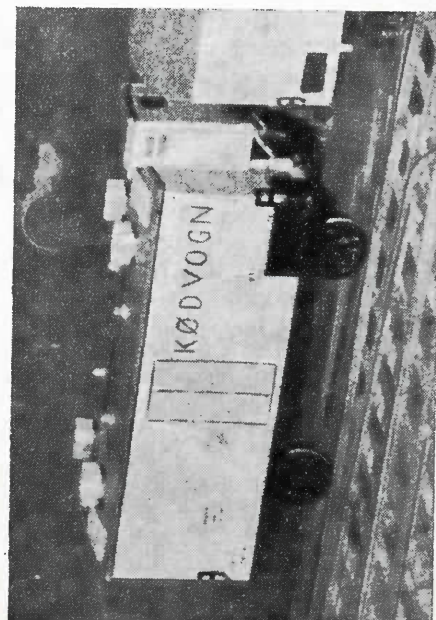

# DSB hvidmalet kødvogn litra IKT

# Privatejede gods- og cisternevogne: Cisternevogn litra ZE

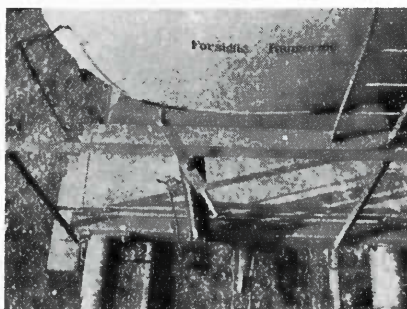
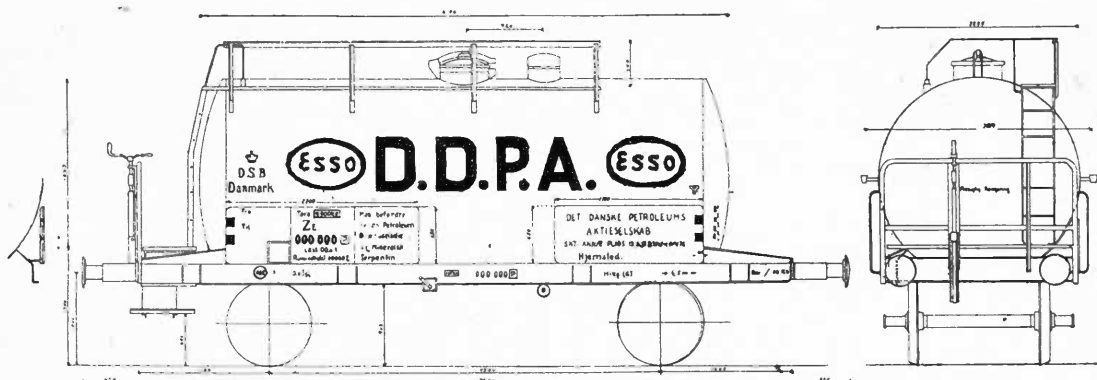
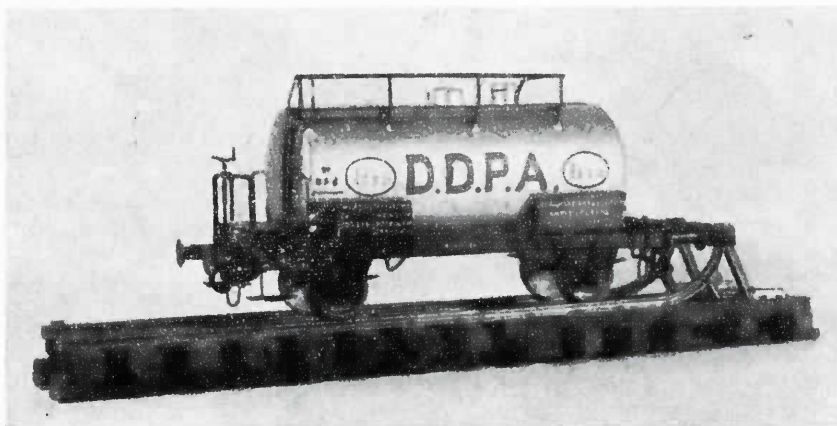

## Tilhører

Det Danske Petroleum Aktieselskab  
Bygget 1948 på Tatraværkerne  
i Tjsekslovakiet. 20 stk. helsvejste  
Nr. fra Ze 502218-Ze502237

## Maling:

Tanken: aluminium  
Påskrift på tank: sorte bogstaver  
Essomærket: Blå-hvid-rød  
Nødbremsehåndtag: rødt  
Kanten af alle skilte: hvid  
Bogstaver på skiltene: Hvid  
Understel, tavler, håndgreb, stiger:  
sort

Målestok 1/87, spor H0

Alle mål i mm virkelig

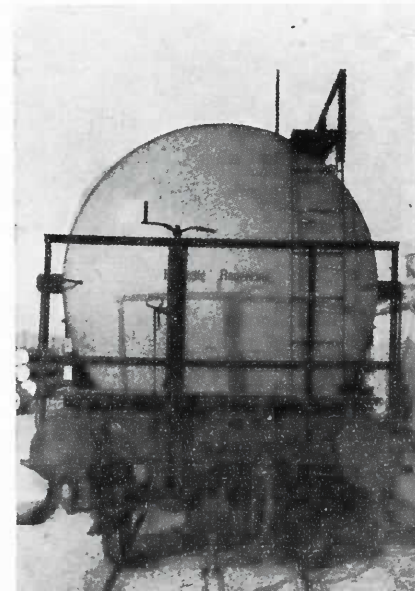
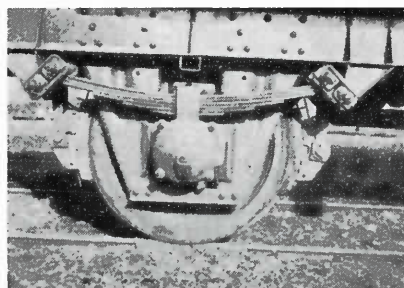

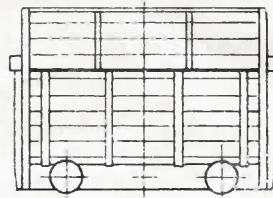
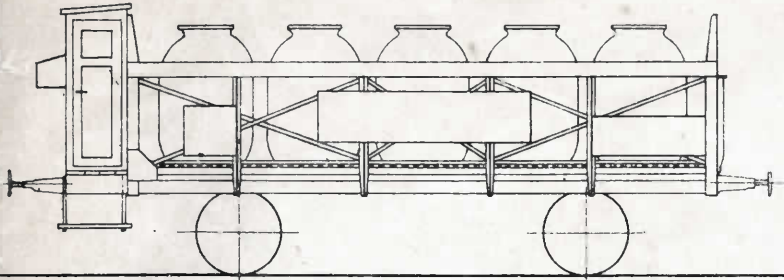

Tilhører  
A/S Dansk Svovlsyre- og  
Superphosphatfabrik  
Målestok 1/87, spor H0

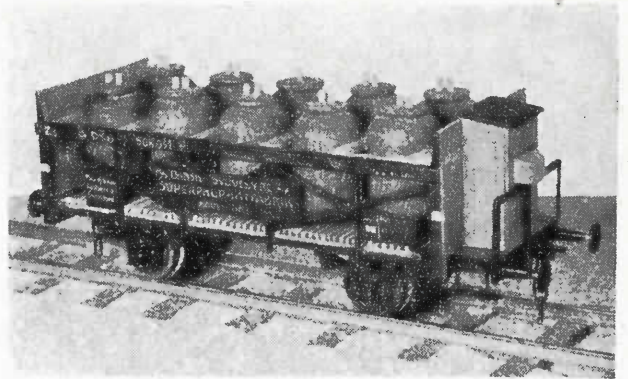
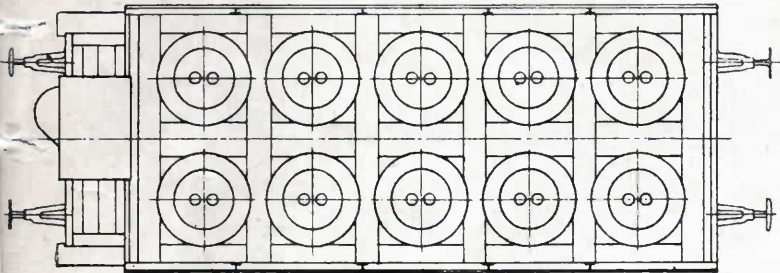

Privatejede gods- og cisternevogne:  
Krukkevogne

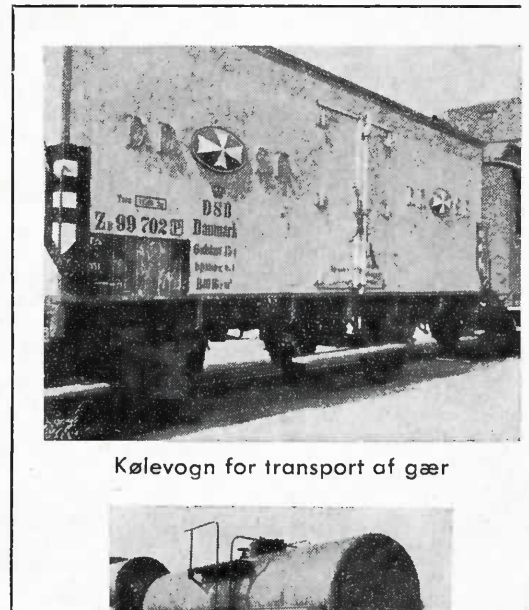

Kølevogn for transport af gær

Privatejede gods- og cisternevogne:  
Gær- og melassevogne



Cisternevogn for transport af melasse

Tilhører De Danske Spritfabriker. Målestok 1/100

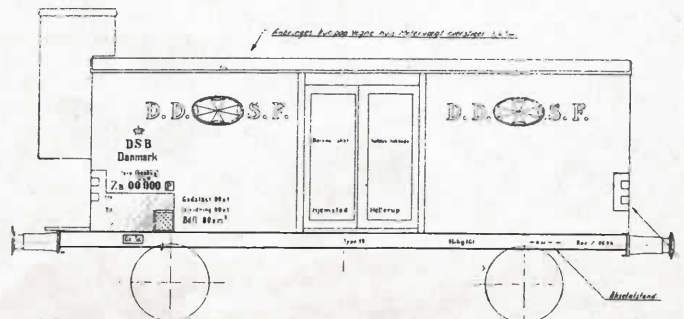
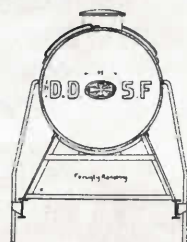
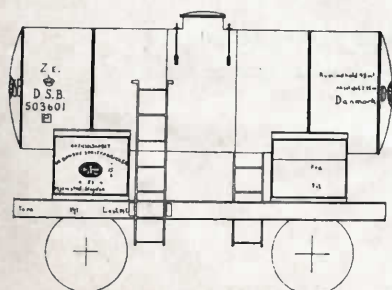

# Privatejede gods- og cisternevogne. Ølvogne Litra Za-Zb

Tilhører Carlsbergs og Tuborgs bryggerier

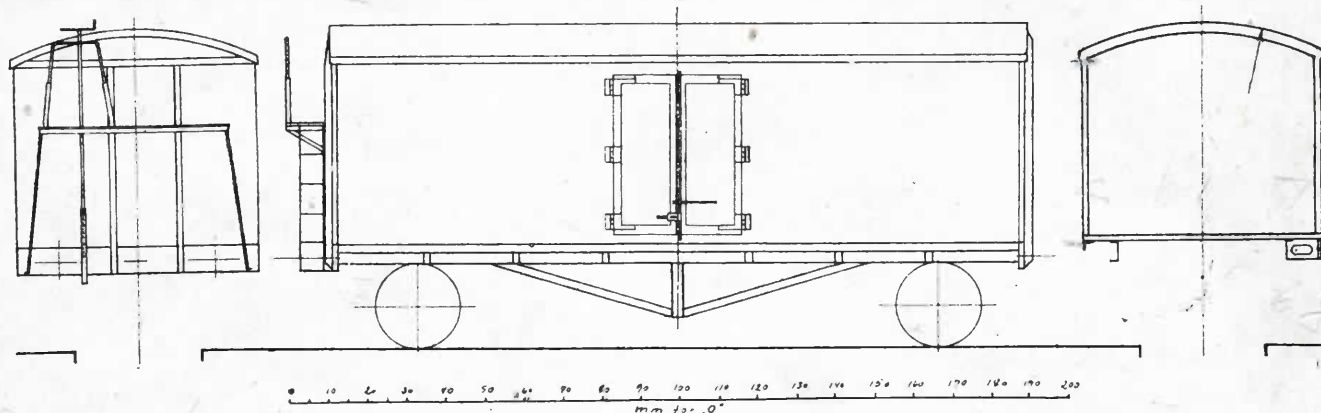

*Dimension 158 x 55*

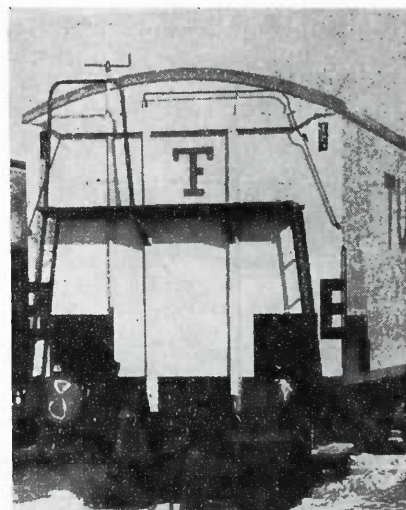

Bygget hos Scandia i Randers 1946-48

Carlsberg: Za nr. 99465-99494

Tuborg: Zb nr. 99616-99635

Ma befordre øl og mineralvande

Last: 18 t. - 600 kg is

Akselafstand: 6 m

Trykluftbremse

Rangerskruebremse

Maling

Hvidmalede med rød og sort påskrift

det store navn er rødt og den mindre

skrift er sort

Undervognen: sort

Tag: tagpap

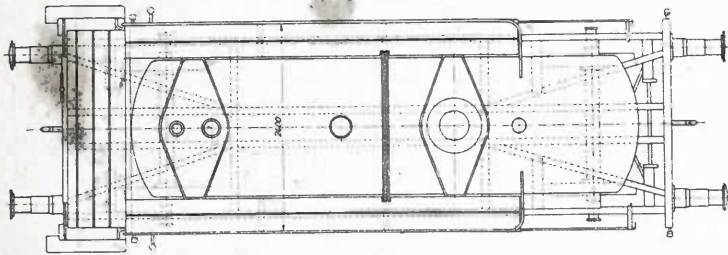
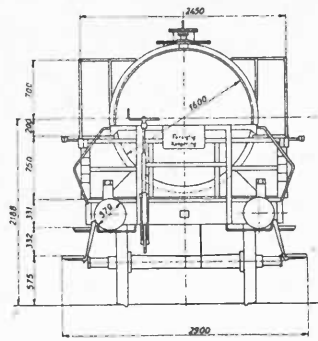
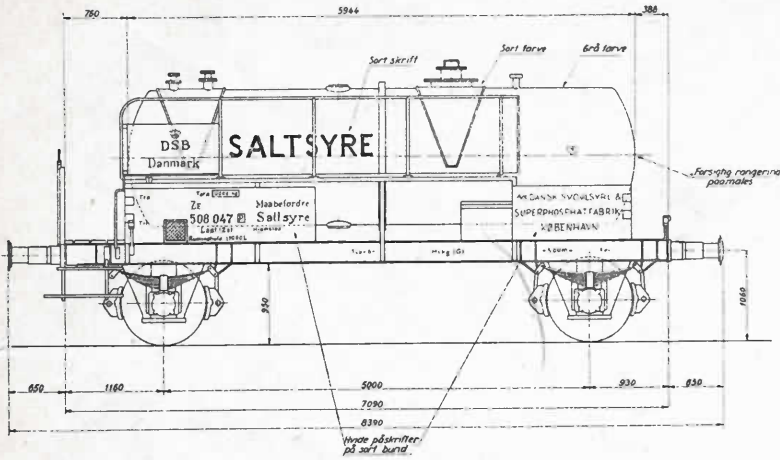

**Privatejede  
gods- og cisternevogne:  
Cisternevogn litra ZE**

Tilhører  
A/S Dansk Svovlsyre og Superphosphatfabrik  
Målestok 1/87, Spor H0

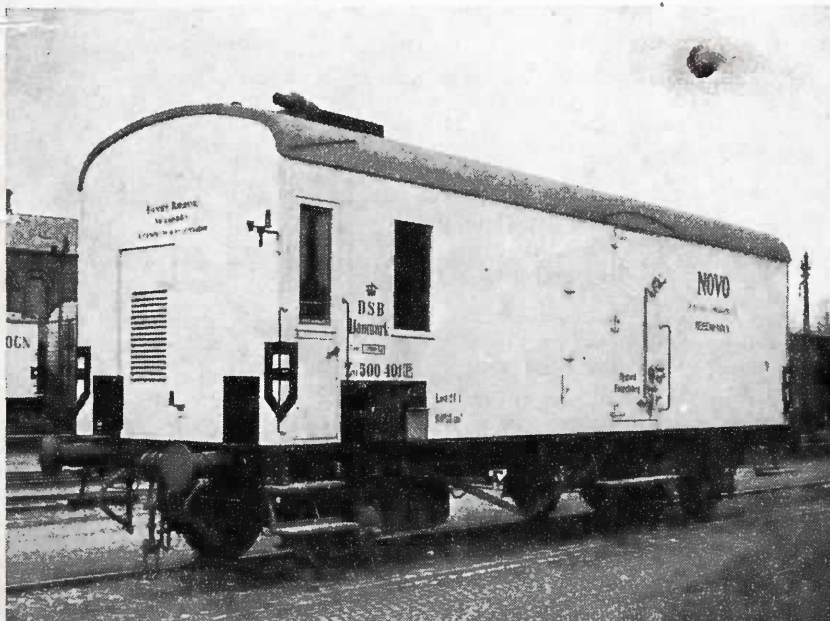

**Maskinkølevogn litra ZM  
nr. 50040**

Tilhører  
NOVO Terepeutisk Laboratorium  
Målestok 1/87, spor H0

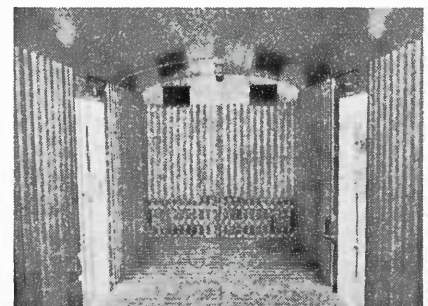



# DSBs svinefold med fast rampe



Målestok 1/100

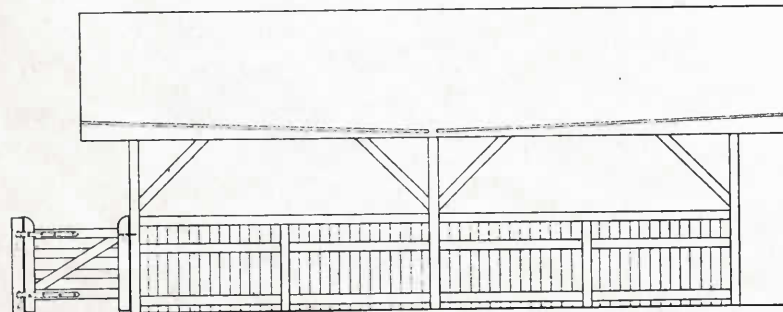
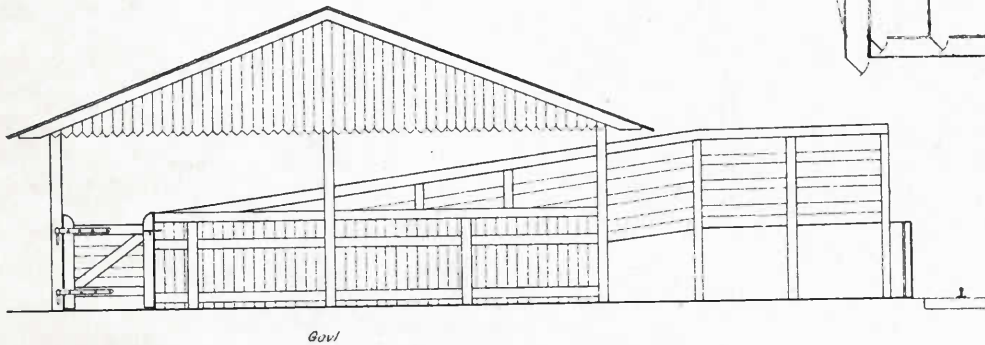
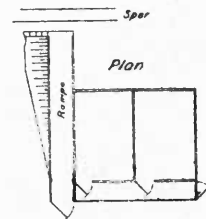

# DSBs 2-sporet remise for motorvogne

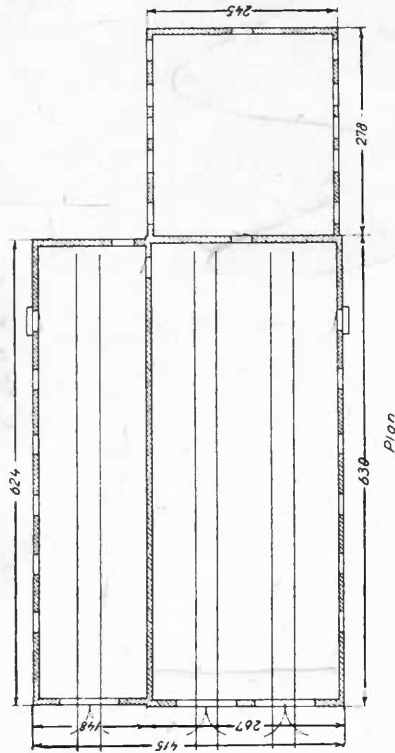
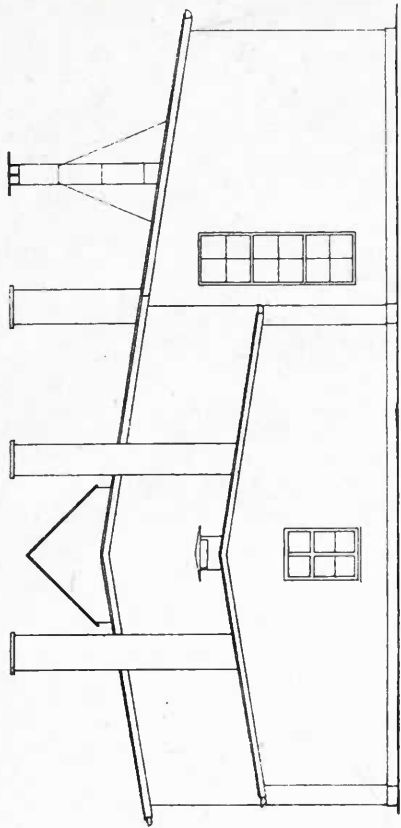
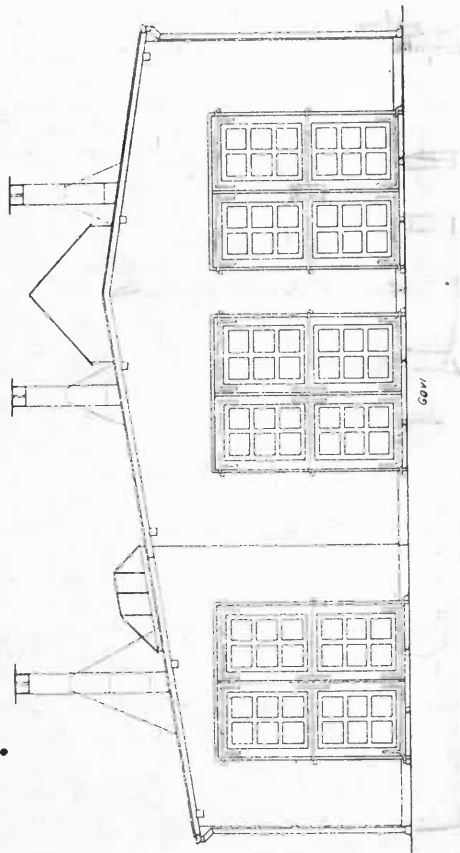

Modellen

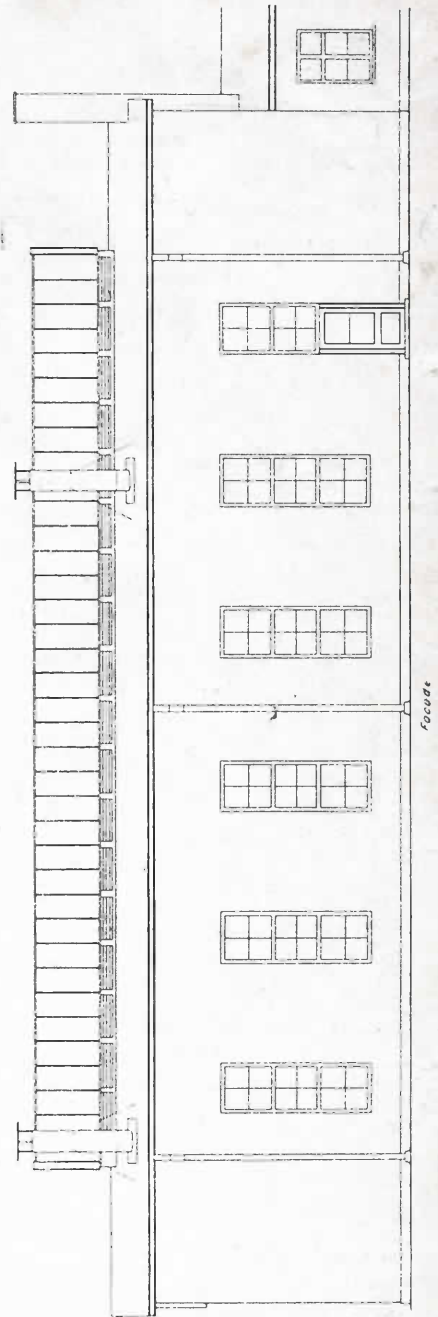

Målestok for facadetegning: 1:180 (1/4 af spor 0, 1/45)  
 Målestok for grundplanen: 1:360 (1/8 af spor 0, 1/45)  
 Målene svarer til spor 0, 1/45



# DSBs vandtårn

Målestok 1/100

passende for bygning i målestok 1/87, spor H0

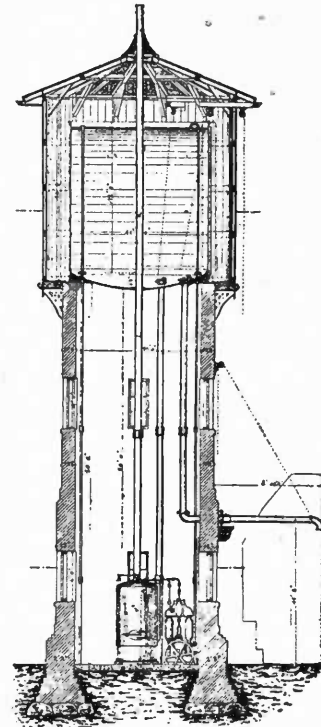
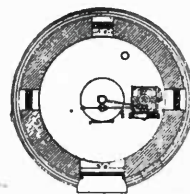
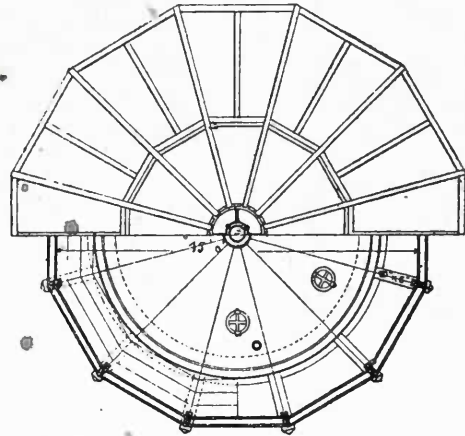
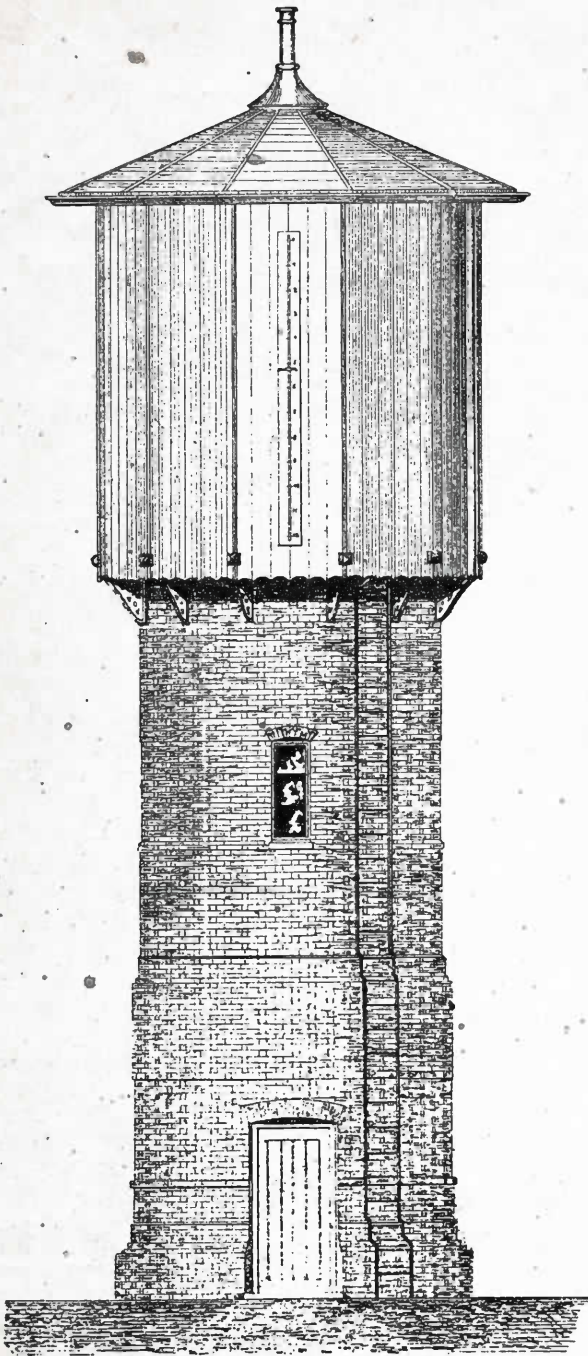

# Drejeskive

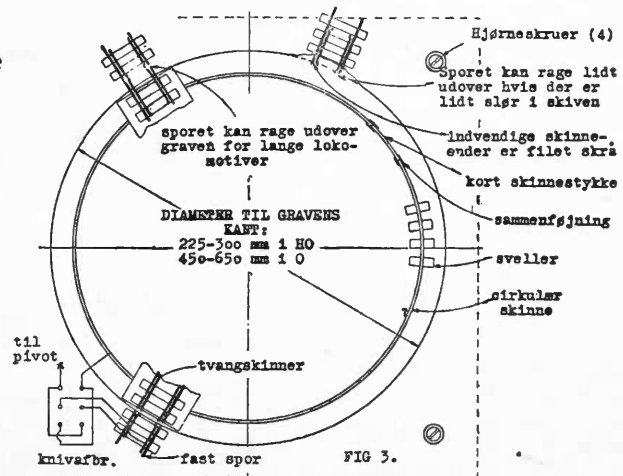

# DSBs signaler

Målestok 1/87, spor H0

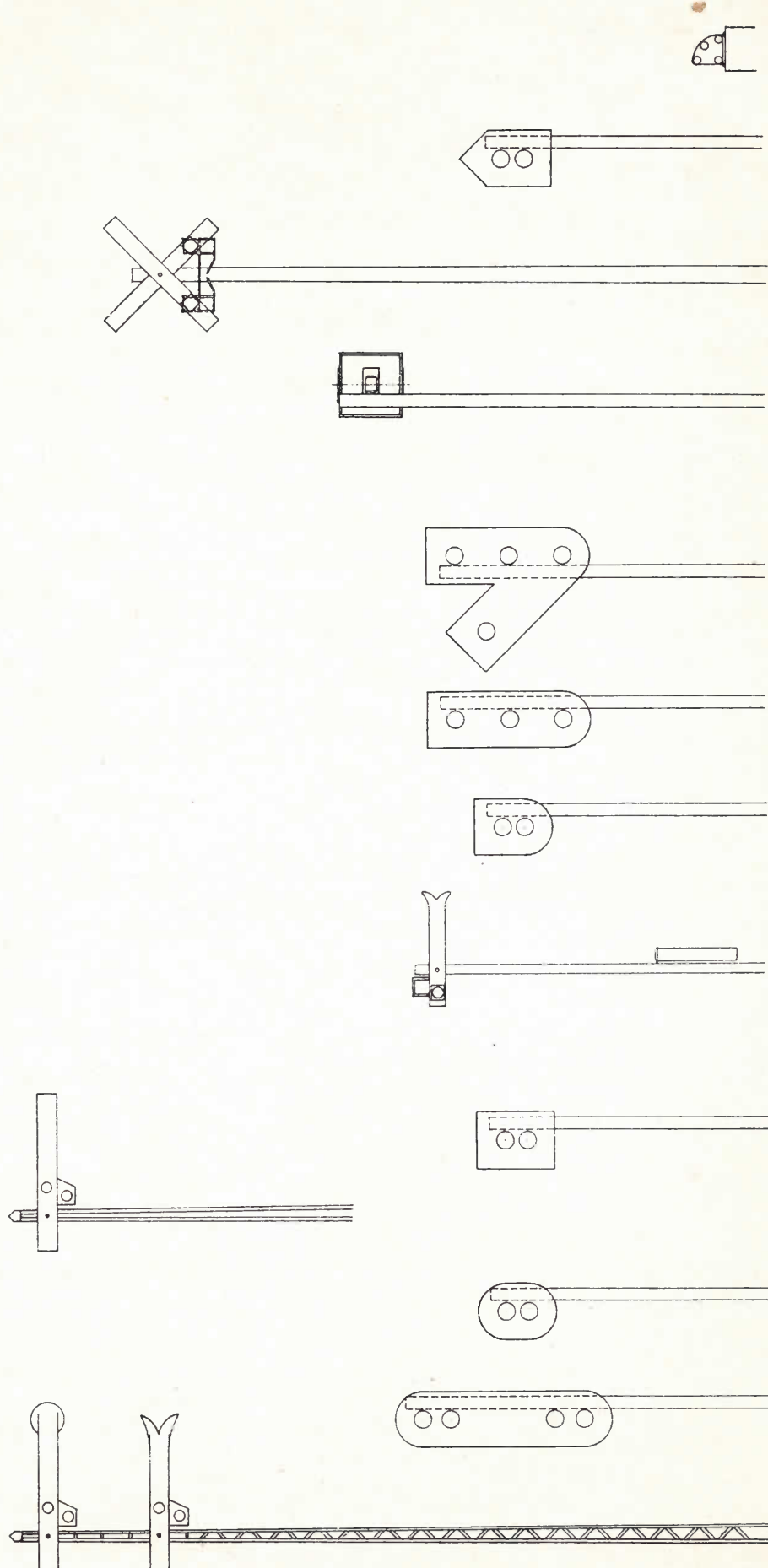



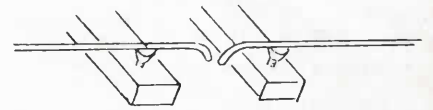
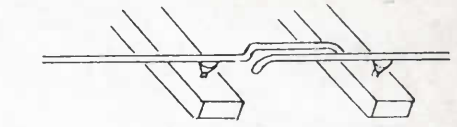
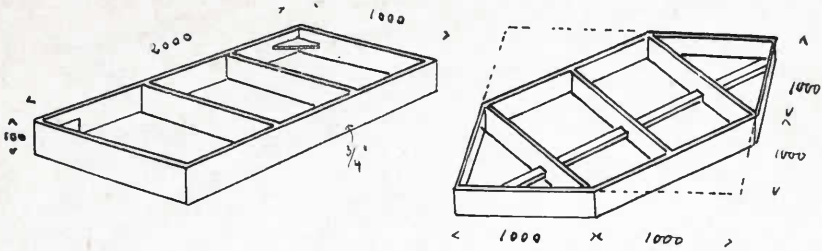

3'skinne-afbrydelse

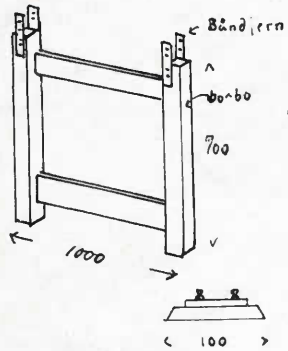
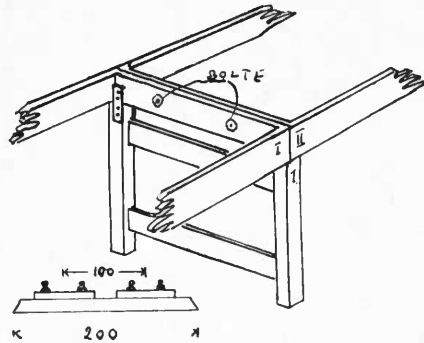
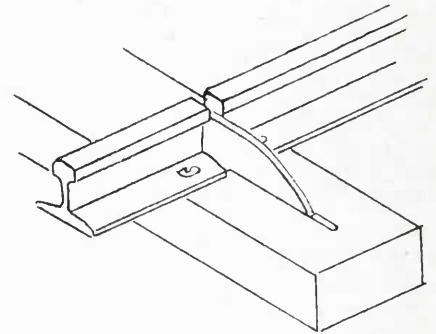

FIG 2



Opbygning af transportable borde



Skinneisolation

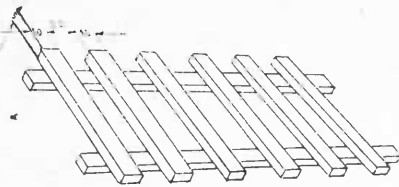

Svellerægning i 1/45, spor 0



Langsveller i kurve

## Broer

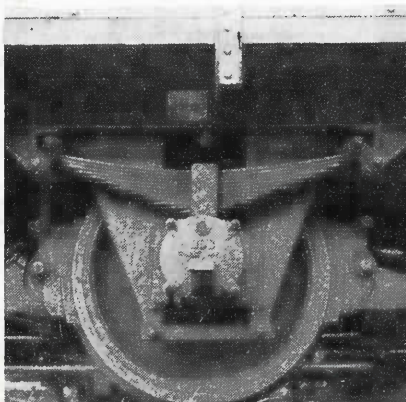
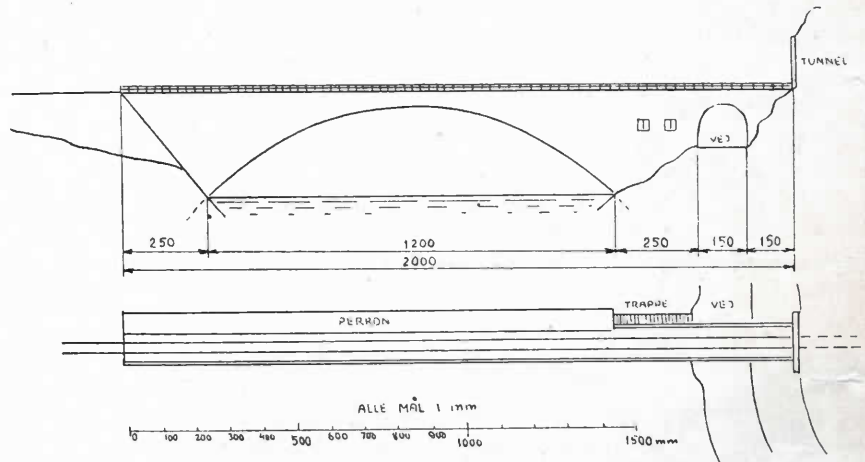
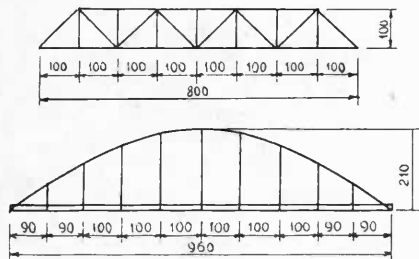

Godsvognshjul m. fjeder og akselkasse

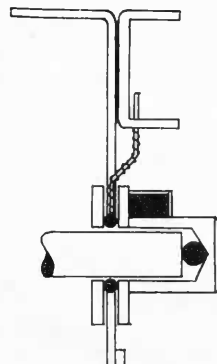

Akselleje, fjedrende model

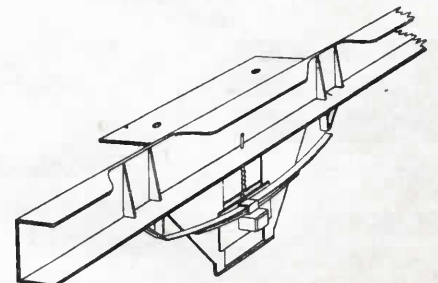

# Sporskiftebygning

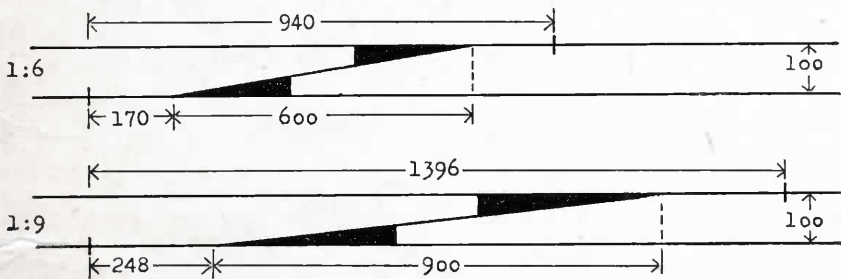
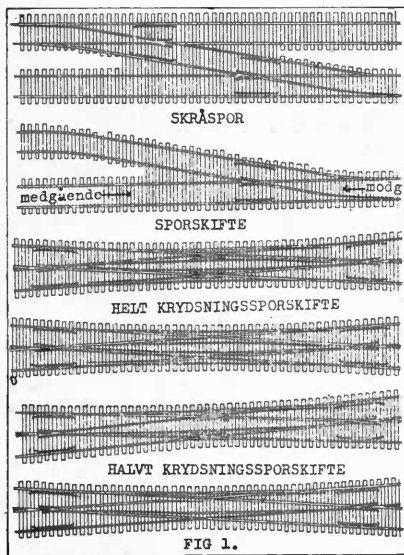
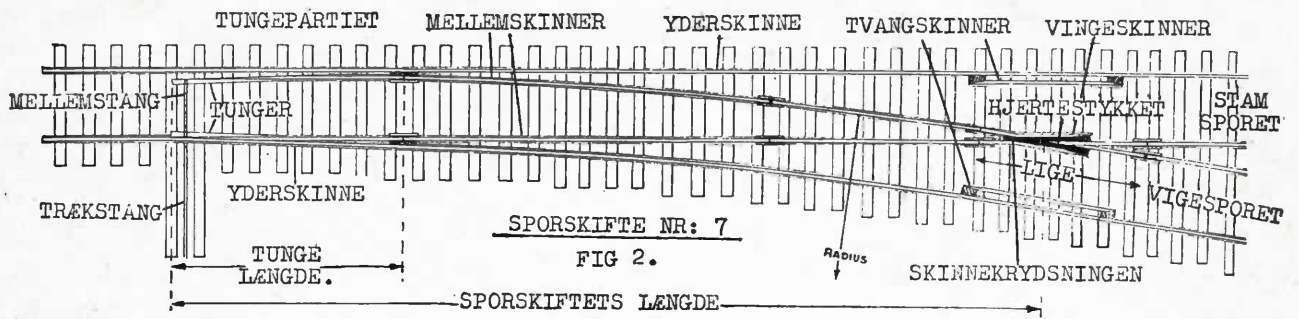

Sporskiftesignaturer

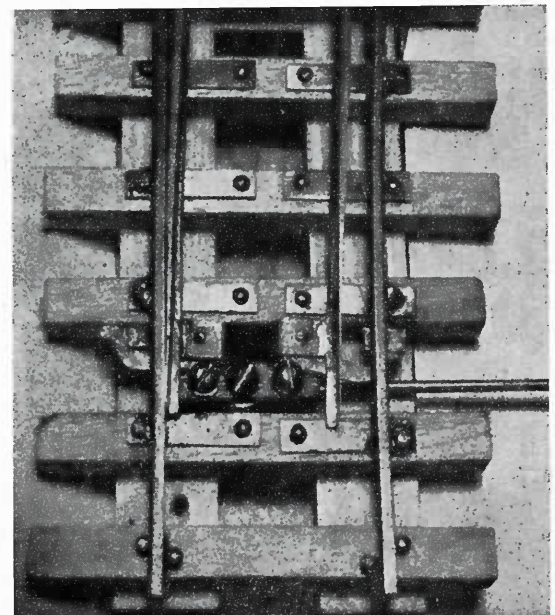
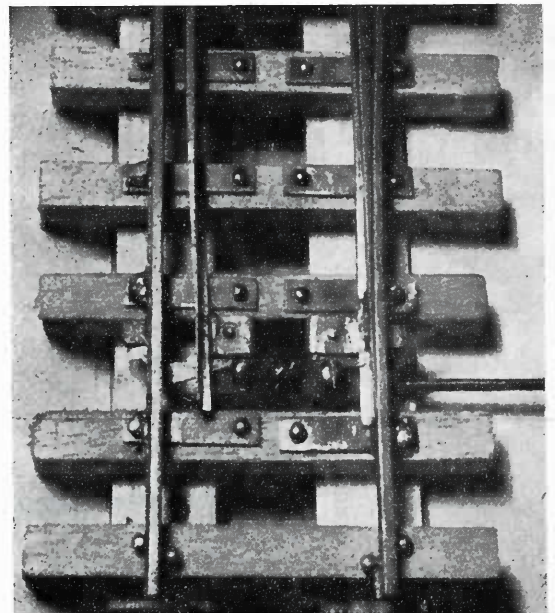
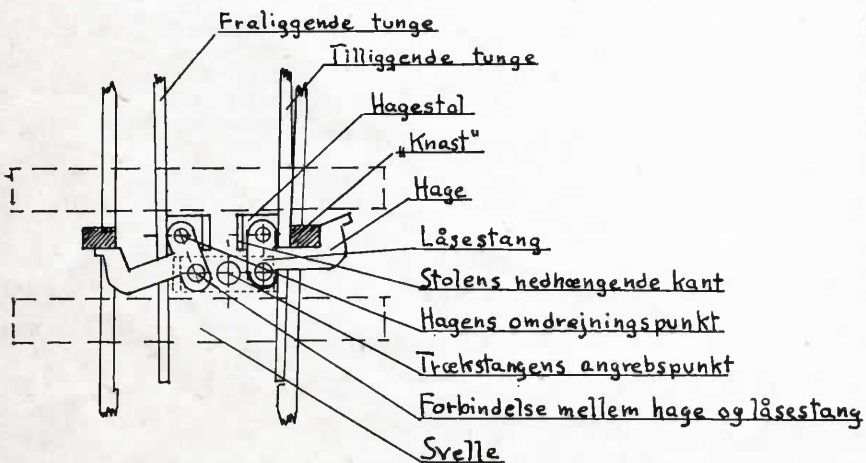

Sporskiftelås



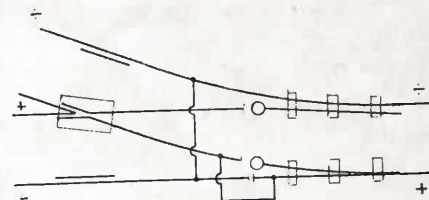
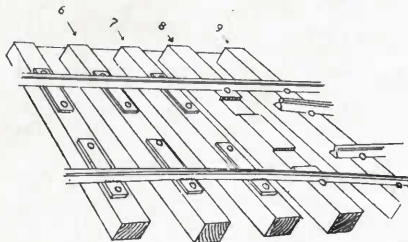
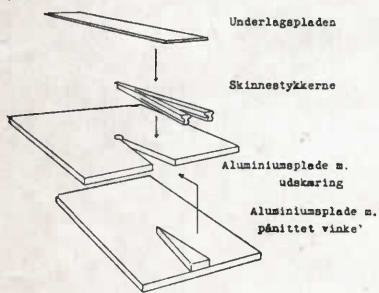
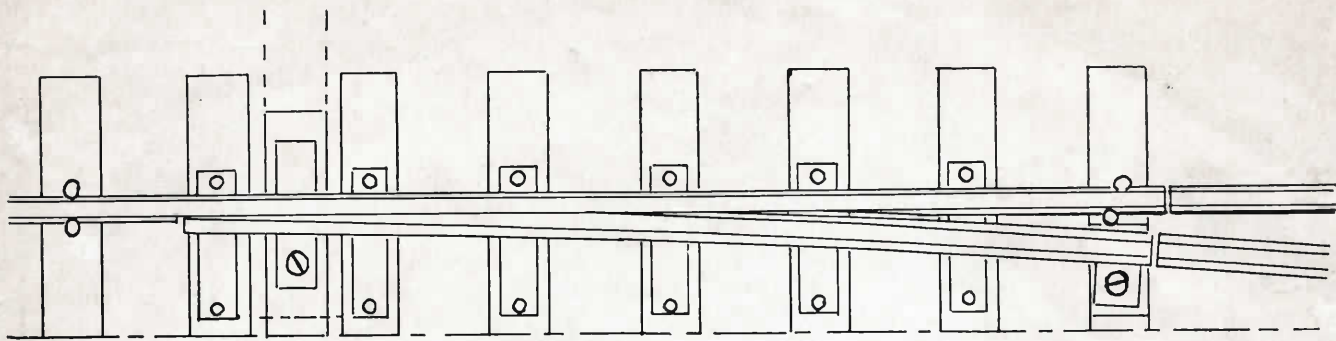

Elektrisk diagram

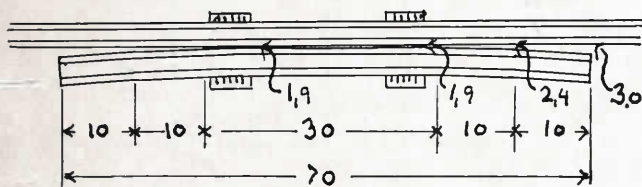

Tvangskinnen

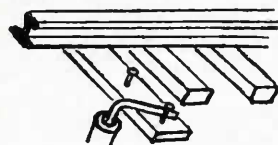

Trækstang



Tunge

## Pufferbygning

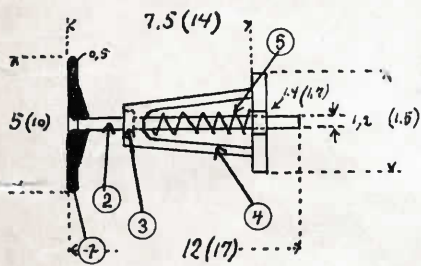

Kurvepuffer

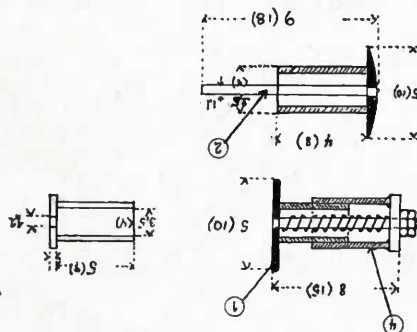

Cylinderpuffer

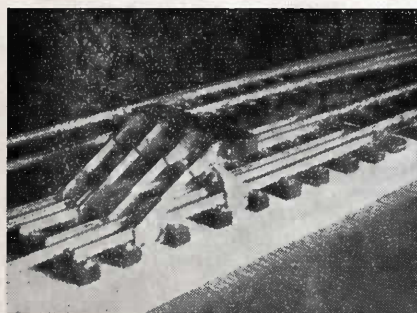
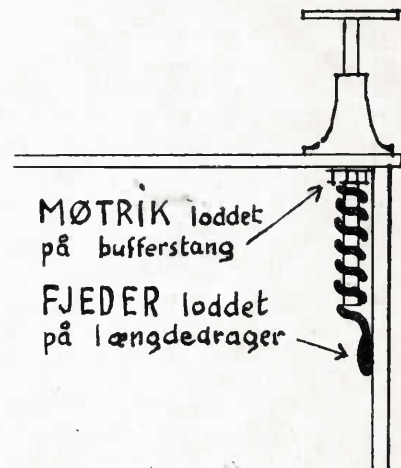

## Stoppebom

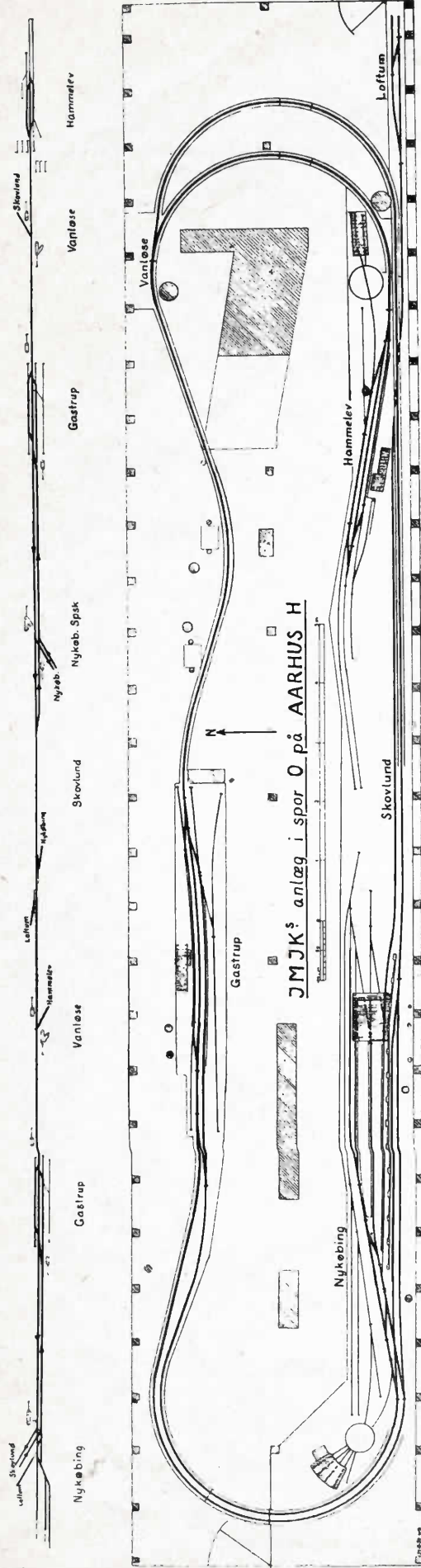

JMK's anlæg i spor 0 på AARHUS H

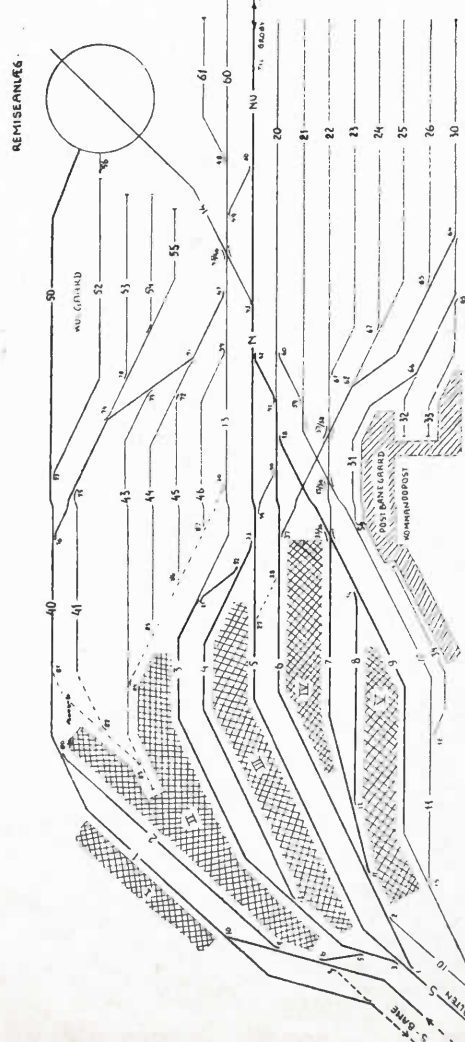
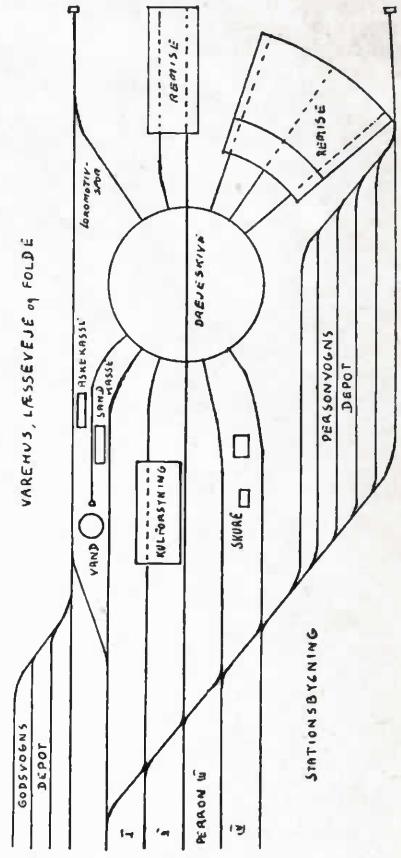
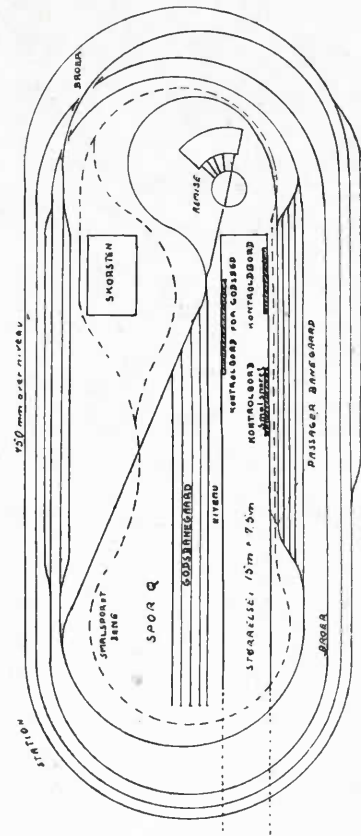

Station

Sporplaner





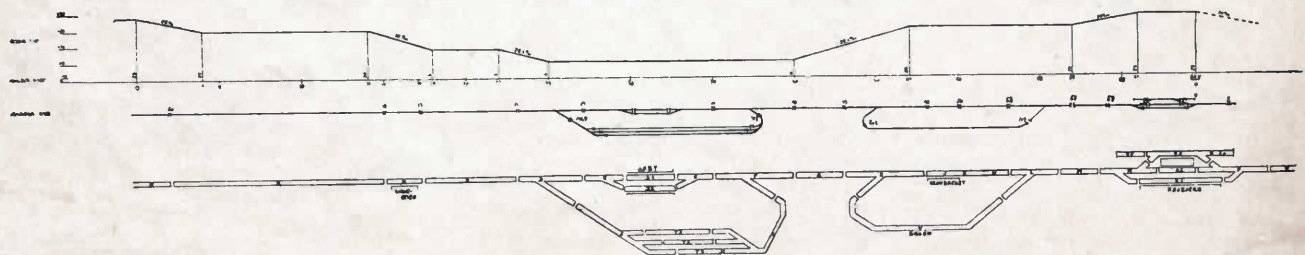
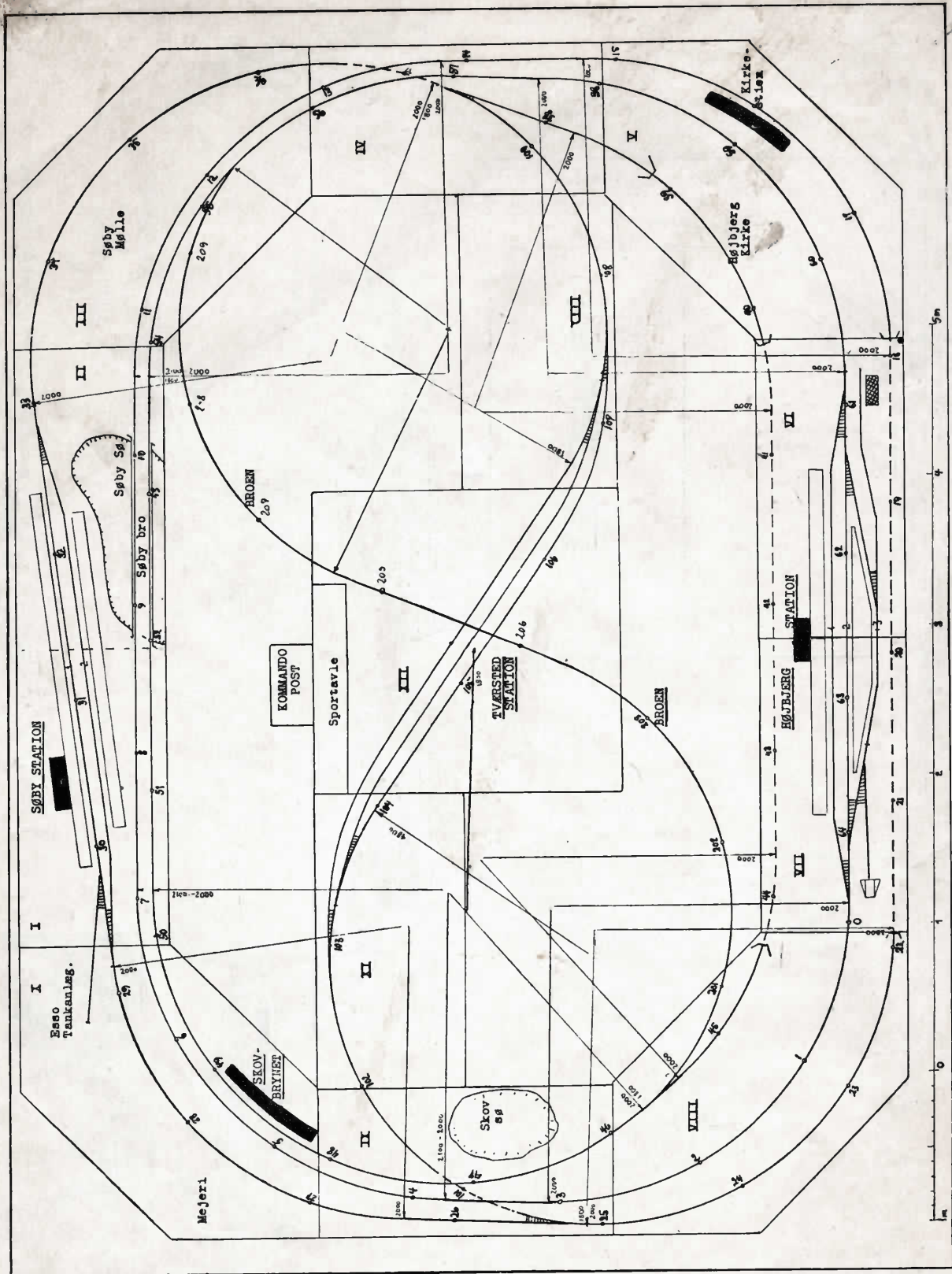

Modeljernbanens transportable anlæg



Er De abonnent på  
„MODELJERNBANEN“

Eneste tidsskrift for  
jernbaner og modeljernbaner  
i Skandinavien

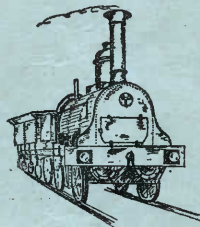

Pris pr. abonnement (12 numre)  
kroner 15.00

Kan tegnes direkte på ethvert posthus  
eller ved indsættelse af beløbet  
på giro 44115

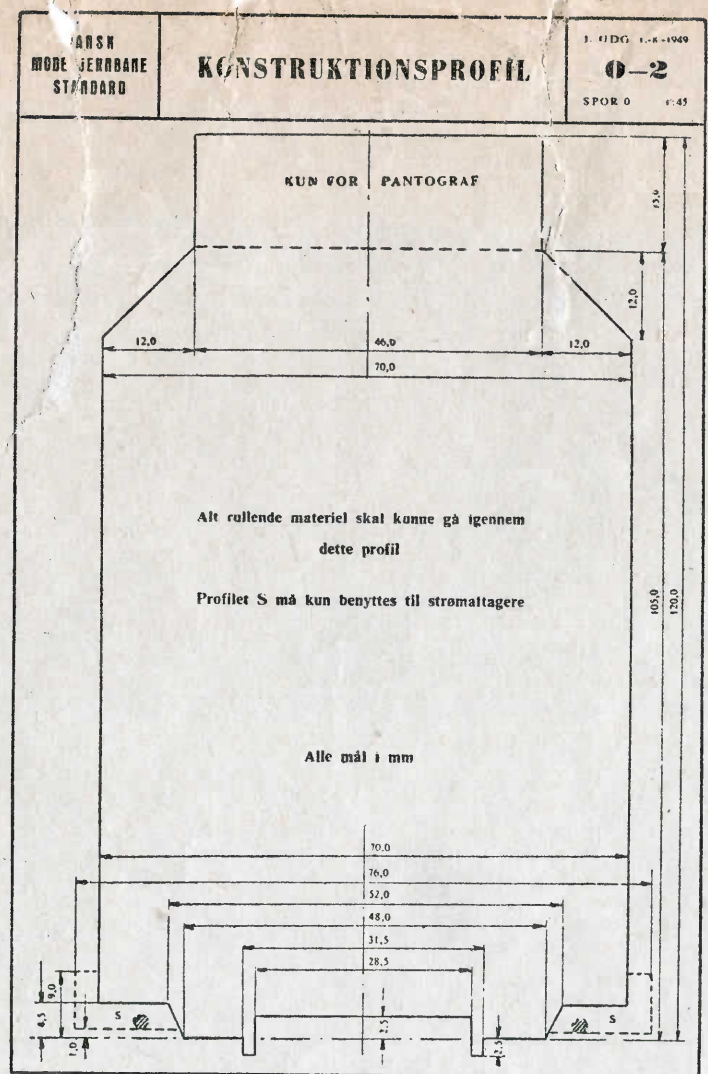
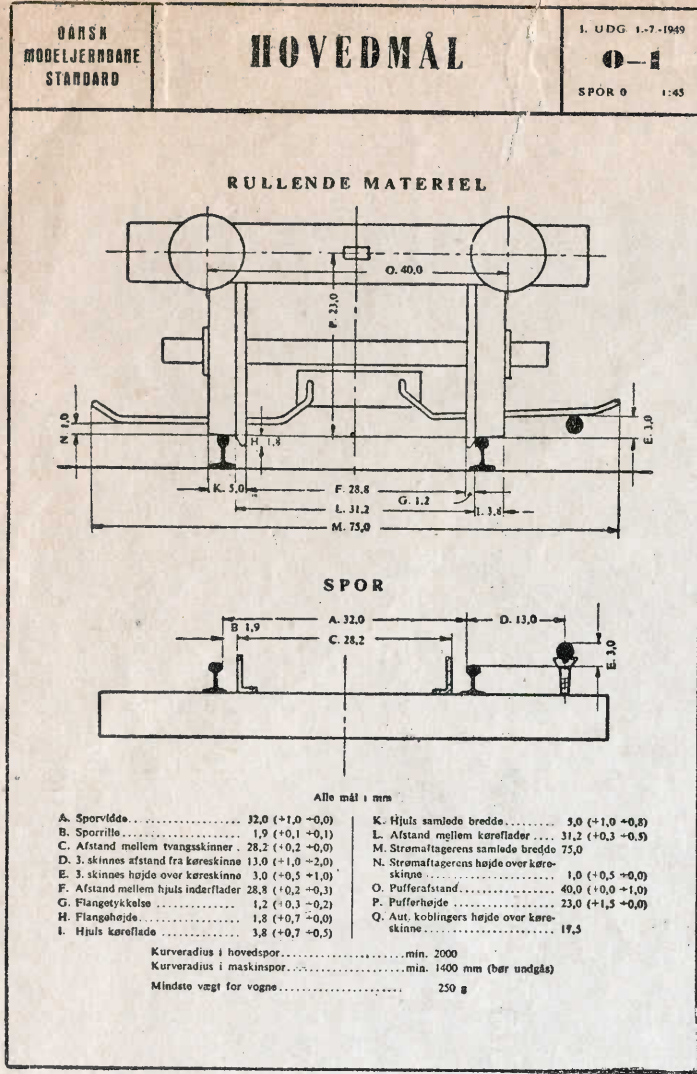

**DANSK MODELJERNBANE STANDARD** **STANDARDS FOR VOGNPUFFER** 1. UDG. 1-12-1949 **0-5** SPOR 0 1:45

For at kunne rangere sikkert gennem 2 m-kurver må følgende mindstemål på vognpuffer overholdes:

Modelvogns længde over puffer: L mm	Puffertype	EKSEMPLER:		
		Litra	Længde i virkelighed m	Længde i model mm
L ≤ 250		DP	10,4	232
		EH	9,5	212
		JA, HD	9,0	200
		Q, P		
250 < L ≤ 325		CX	13,5	300
		DA	11,5	285
		EC	13,2	294
325 < L ≤ 400		CP	17,7-18,9	393-353
400 < L ≤ 450		CM	20,0	445
		CB	19,4	432
450 < L ≤ 500		AC, AU, AV, AX, CA, CB, CL, MO	21,7	483
			20,9	469
500 < L ≤ 524		S1 Internationale øvre- og østevogne	23,0	520

b skal være mindst 8

Alle puffer set fra oven:

Længde vogn..... 524 mm (~23,5 m)  
 Afstand mellem puffermidter..... 40 (+0, -1)  
 Puffermidtet..... 23 (+1,5, 0)

Dansk  
 modeljernbane  
 standard

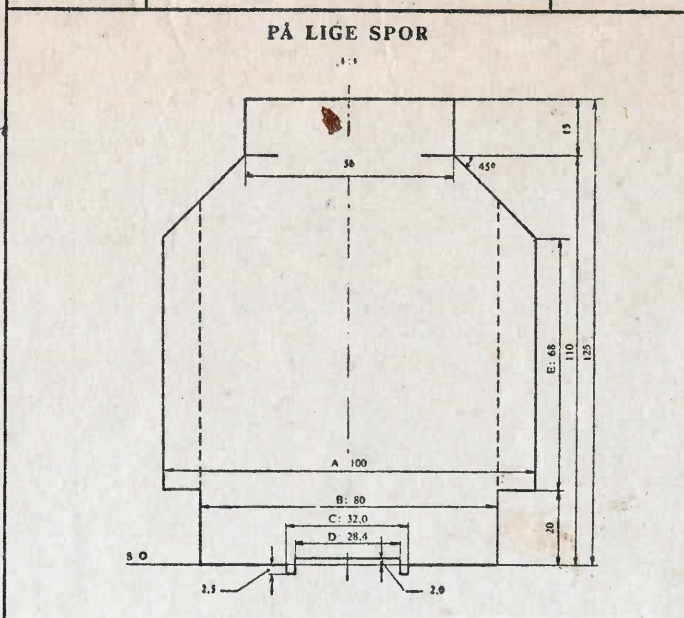

— Fritrumsprofil for spor på fri bane og stationers hovedspor  
 - - - Fritrumsprofil for andre spor  
 Normal sporafstand: 100 mm såvel i lige som i kurve

**I KURVER**

	A		B		C		D		E	
	tilleg	lalt	tilleg	lalt	tilleg	lalt	fradrag	lalt	fradrag	lalt
R = 4000	+14	114	+14	94	0	32,0	0	28,4	-7	61
R = 3000	+16	116	+16	96	0	32,0	0	28,4	-8	60
R = 2000	+20	120	+20	100	+1,0	33,0	+1,0	27,4	+10	58
R = 1600	+26	126	+26	106	+1,0	33,0	+1,0	27,4	+13	55

Alle mål i mm  
 Alt fast opstående skal holdes uden for fritrumsprofilen

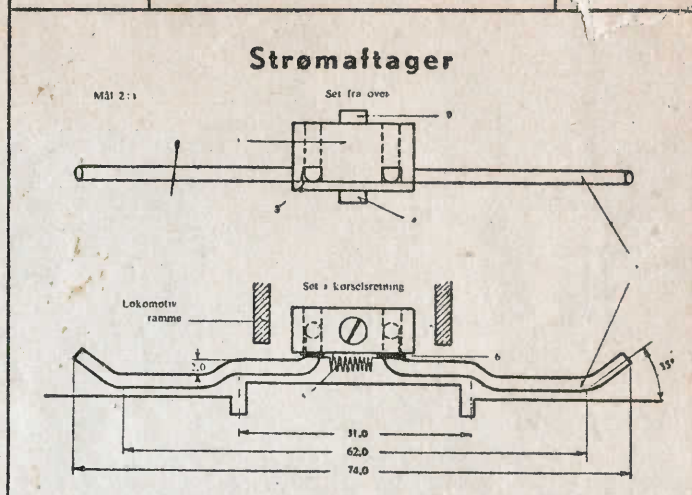

**Beskrivelse:**  
 Strømtageren består af en messingklods (1) med 2 udfræsedde riller og 2 gennemboede huller, hvori den ombojede del af armene (2), der er af 2 mm klavertråd, stikkes ind. Armene holdes inde af pladen (3), der igen holdes på plads af skruen (4). Kontaktrykket fås ved en spiraljeder (5), der har fat i den lodrette del af armene under en skive (6). (7) er befæstelsesskruen

**Regler for anbringelse:**  
 Strømtageren skal monteres således, at den vandrette underkant er 1,0 mm over S.O. (tolerancer + 0,5 mm, - 0). Kontaktrykket på en tredieskinne i normal højde skal være mindst 30 g.  
 En strømtager må ikke anbringes mere end 40 mm foran eller bag en fast aksel, hvis hjul deltager i køretøjets styring. Ved bogjeevogne skal strømtagerene anbringes på boggiene.  
 For at undgå stødvis gang skal der i ethvert tog være to virksomme strømtager, hvis afstand, målt i togets længderetning, såvidt muligt bør være mindst 150 mm. Forreste strømtager må højst befinde sig 400 mm bag forreste aksel i toget.

**Standard for spænding m.v.:**  
 Kørespændingen skal være enten 12 volt jævnspænding eller 20 volt vekselspænding. På fri bane skal tredieskinne i førstnævnte tilfælde altid være positiv i forhold til køreskinne.  
 Sikkert der i et tog findes ubenyttede strømtager, må disse ikke være i elektrisk forbindelse indbyrdes.  
 Omstyring af kørselsretningen skal kunne foretages på selve toget. Omskifteren skal have en mellemstilling, hvor motorstrømløbet er afbrudt; hvis omskifterbetjening foregår på tværs af køretøjet, skal højre yderstilling svare til fremadskørsel

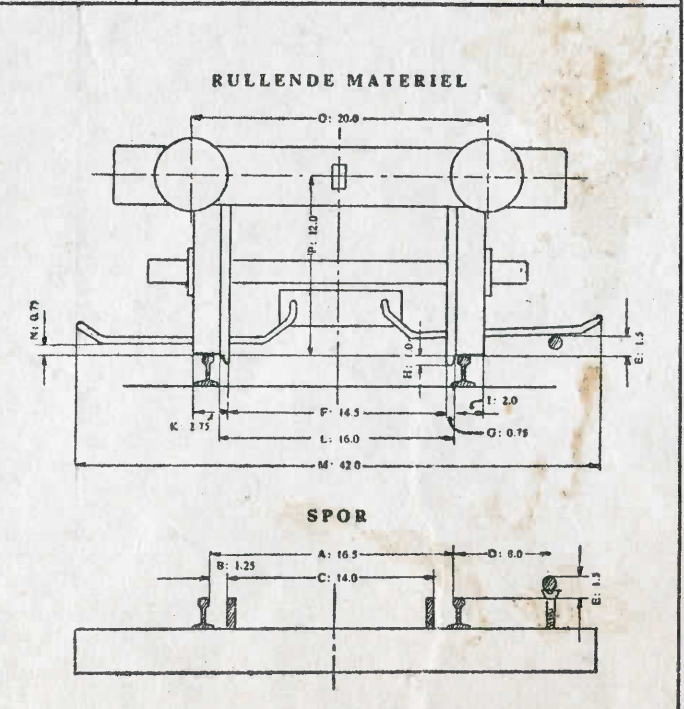

A. Sporvidde	16.5	I. Hjuls køreflåde	2.0
B. Sporrille	1.25	K. Hjuls samlede bredde	2.75
C. Afstand mellem tvangsskinne	14.0	L. Afstand mellem køreflader	16.0
D. 3. skinnes afstand fra køreskinne	8.0	M. Strømtagerens samlede bredde	42.0
E. 3. skinnes højde over køreskinne	1.5	N. Strømtagerens højde over køresk	0.75
F. Afstand mellem hjuls inderflader	14.5	O. Pufferafstand	20.0
G. Flangetykkelse	0.75	P. Pufferhøjde	12.0
H. Flangehøjde	1.0	Q. Aut. koblingers højde over køresk	10.0

Alle mål i mm

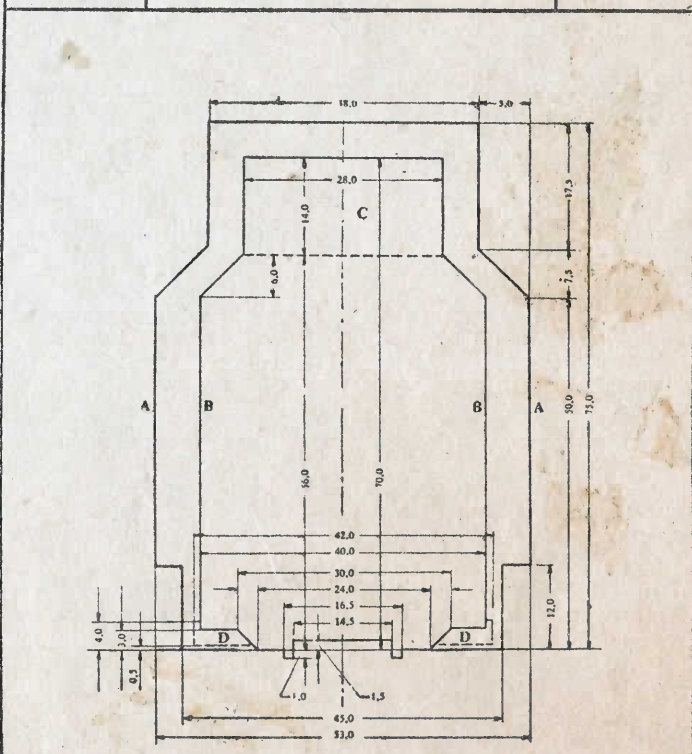

A. Fritrumsprofil. Alle faste genstande skal holdes uden for dette profil.  
 B. Konstruktionsprofil. Alt rullende materiel skal kunne gå igennem dette profil.  
 C. Dette profil må kun benyttes til pantografer.  
 D. Dette profil må kun benyttes til strømtagerer.  
 Normal sporafstand på lige spor og i kurver er 55.0.  
 Alle mål i mm