

12833

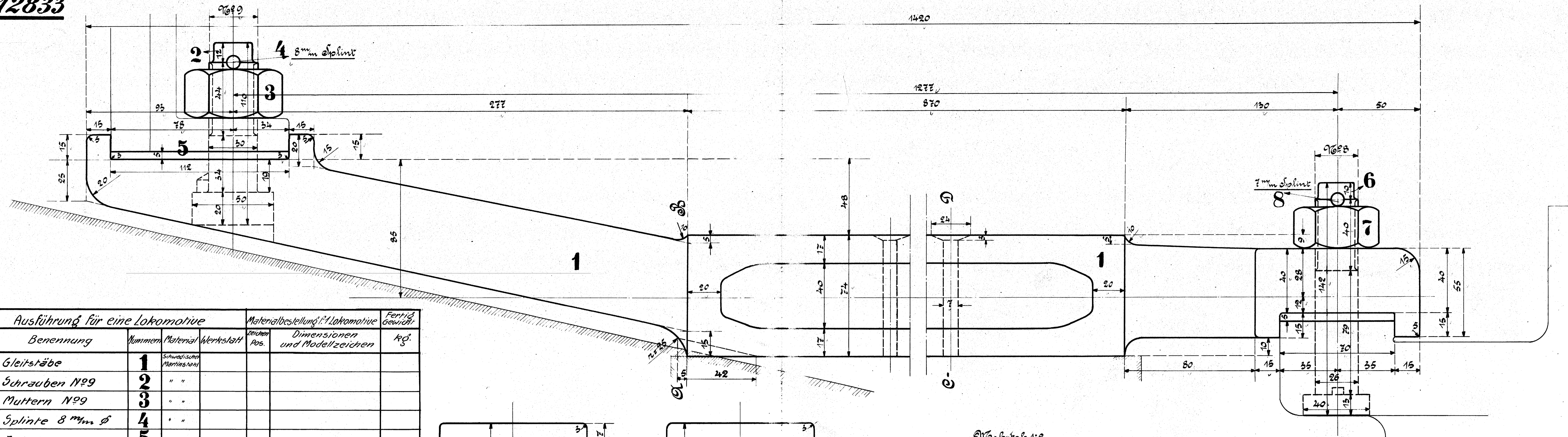

Ausführung für eine Lokomotive				Materialbestellung f. Lokomotive		Fertig Gewicht	
Stück zahl	Benennung	Nummern	Material	Werkstatt	Zeichen Pos.	Dimensionen und Modellzeichen	Kg.
2	Gleitstäbe	1	Schwedischer Martinstahl				
2	Schrauben N°9	2	"				
2	Muttern N°9	3	"				
2	Splinte 8 mm Ø	4	"				
2	Zwischentlagen	5	Messing				
4	Schrauben N°8	6	F. E.				
4	Muttern N°8	7	"				
4	Splinte 7 mm Ø	8	"				
2	Zwischentlagen	9	Messing				

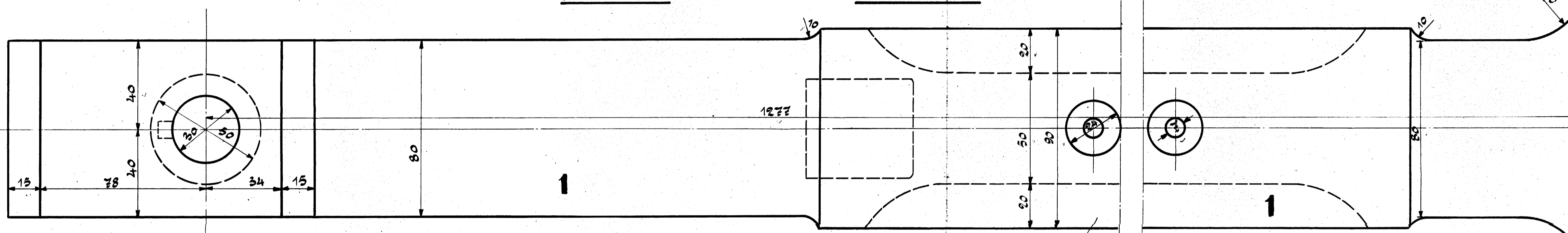
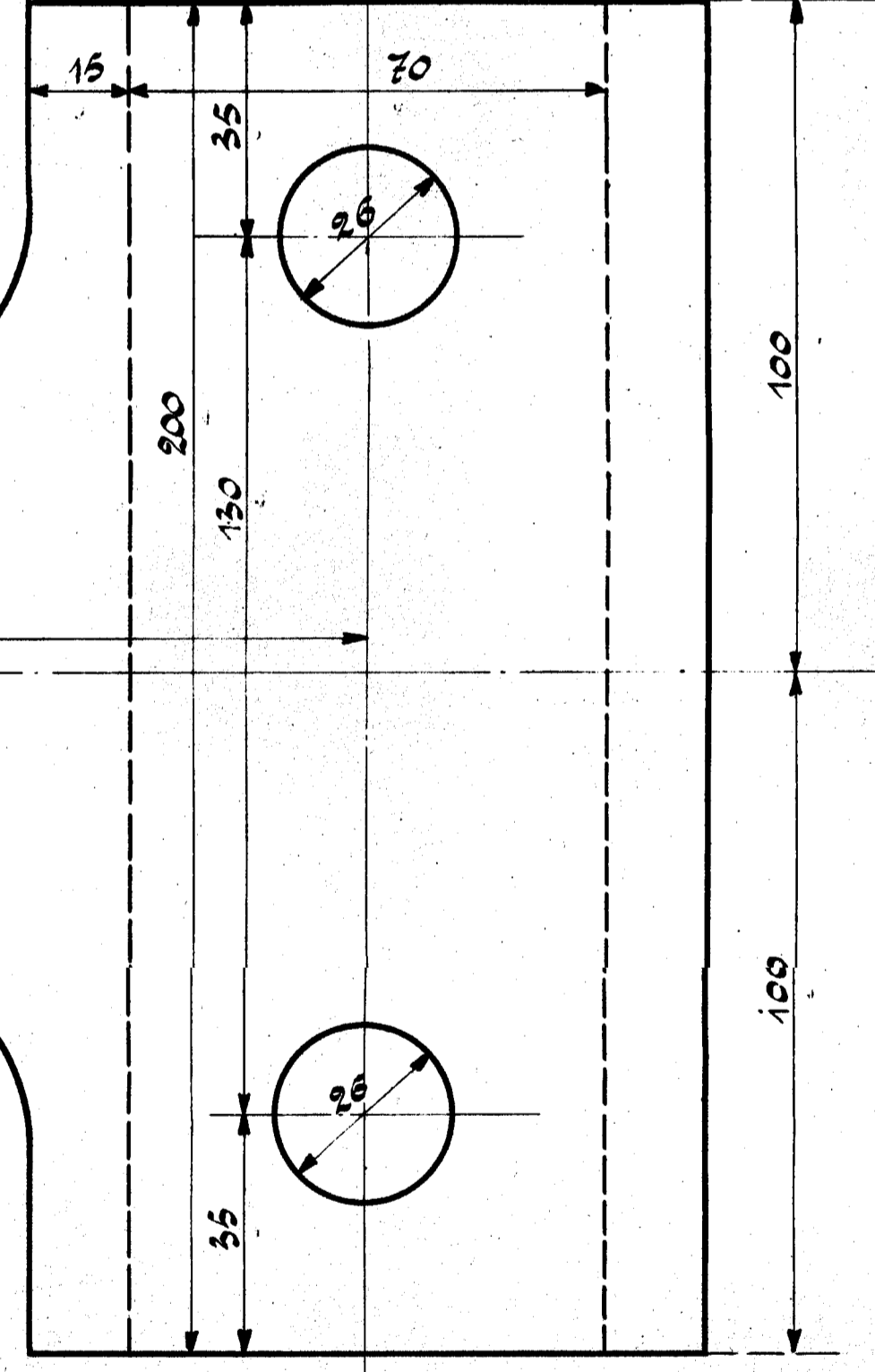
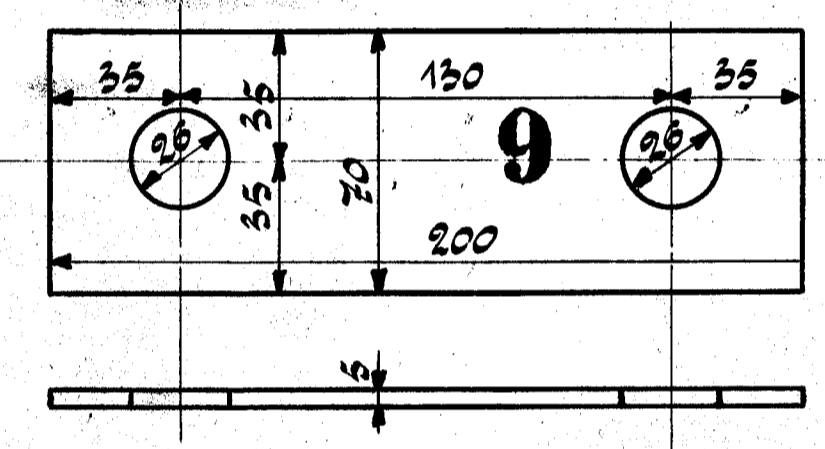
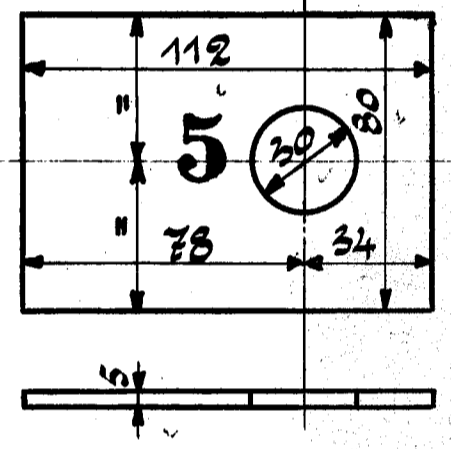
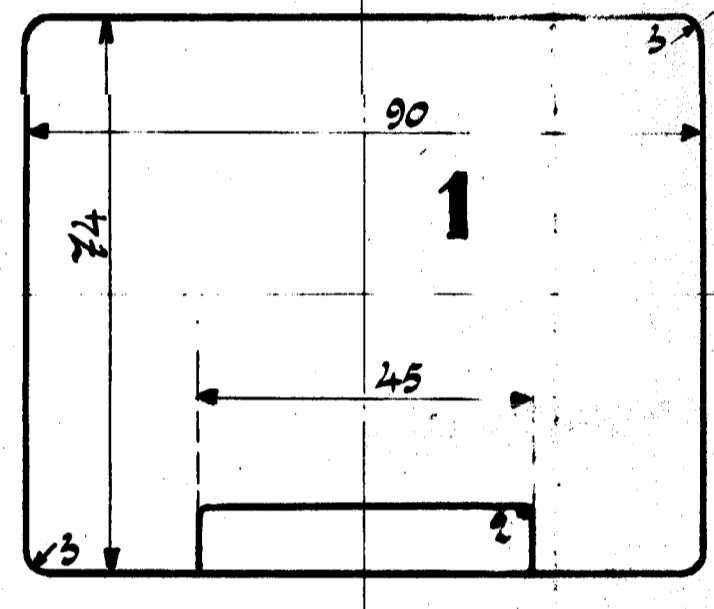
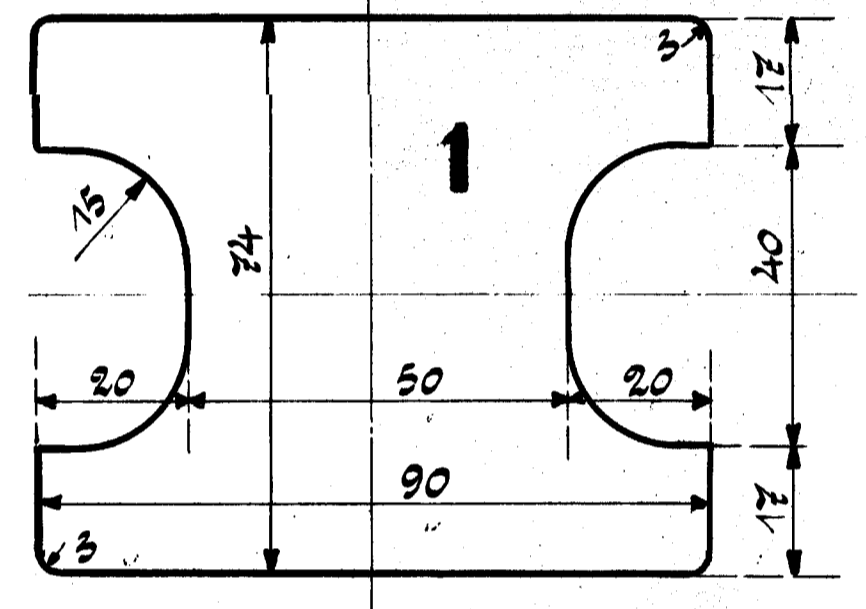

Schwedischer Martinstahl Niobgehalt 0,30 %
Einsetzen und härten!

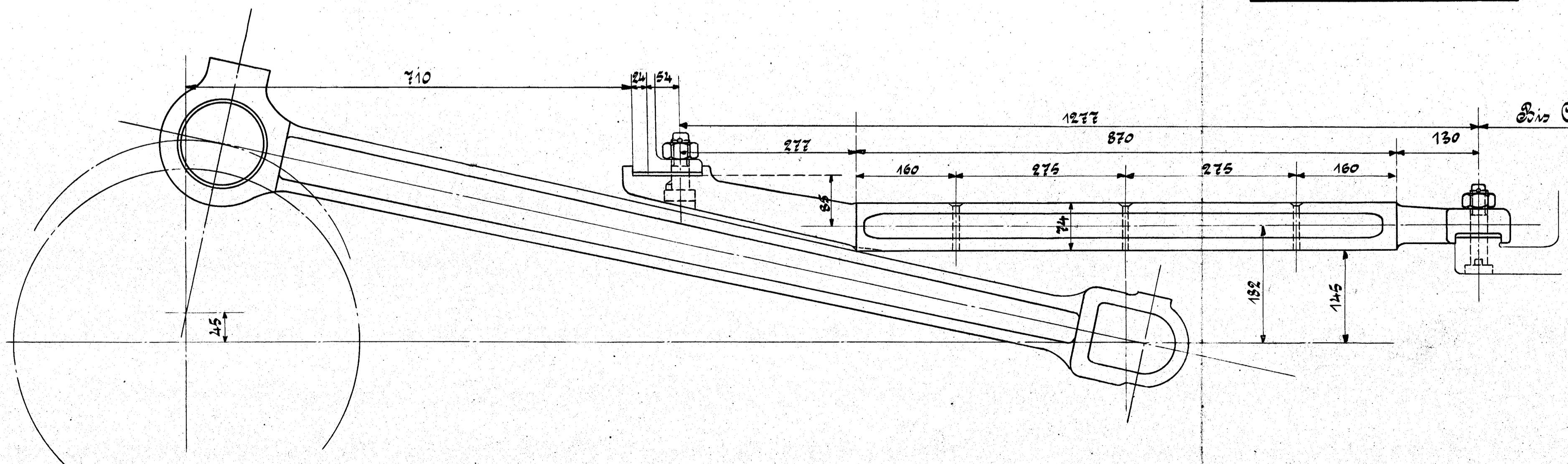

HENSCHEL & SOHN
CASSEL

Leitstäbe.

Leitstäbe
z. d. 1 C1-Heißd-Tender-Lokomotive

Fabr. N° Zeichn. N° 193