

T. F. J.
Danmark

101

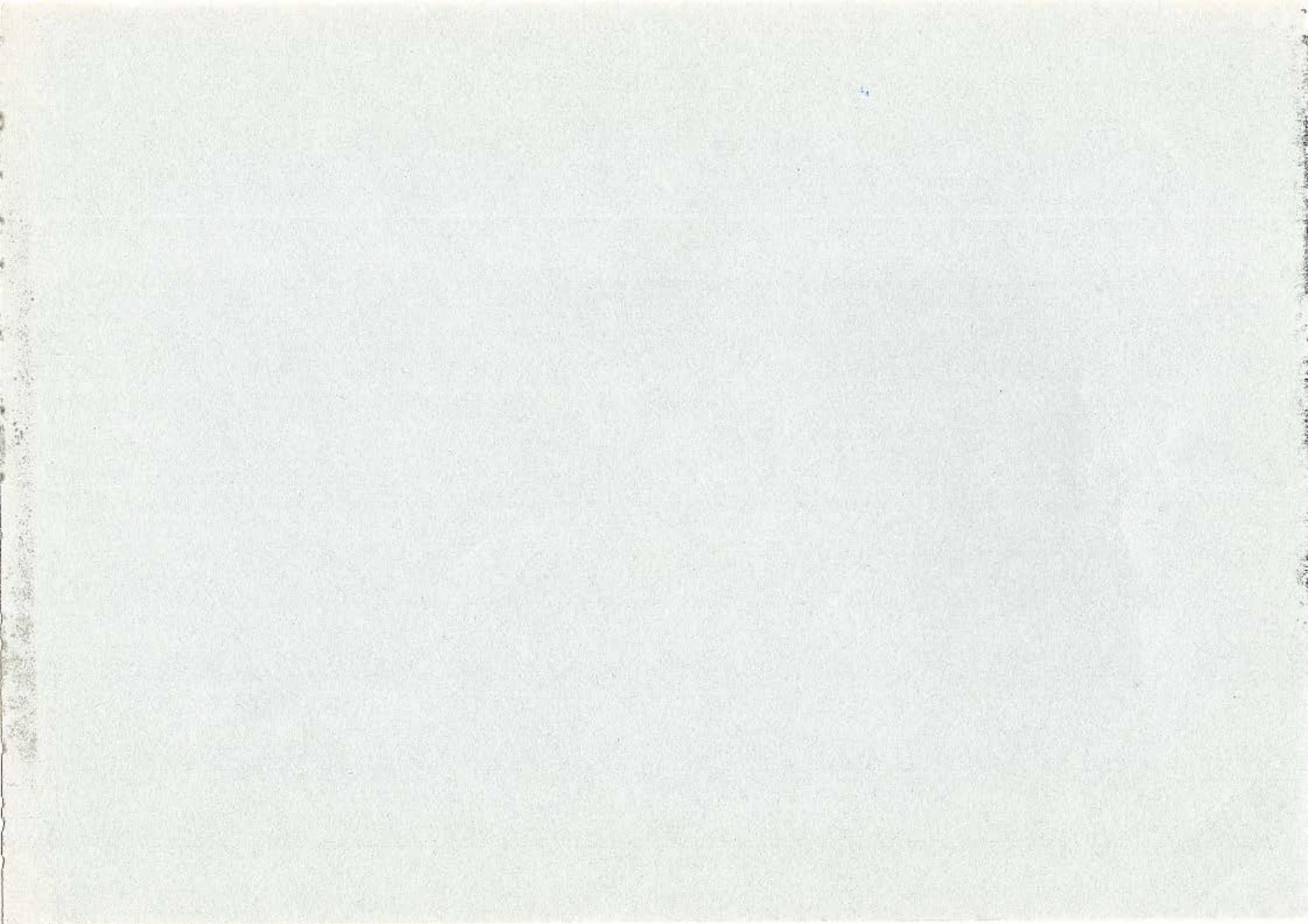

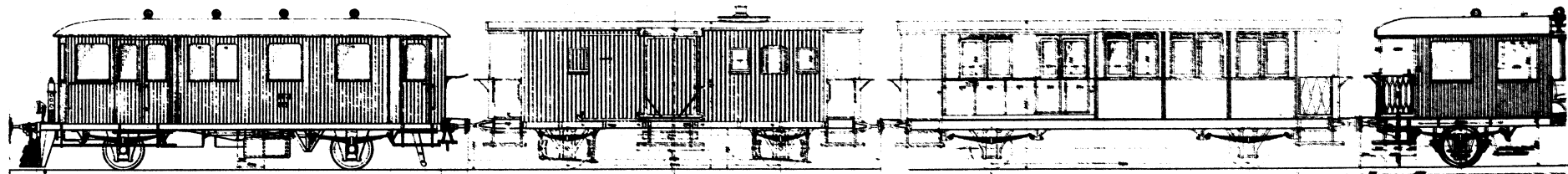
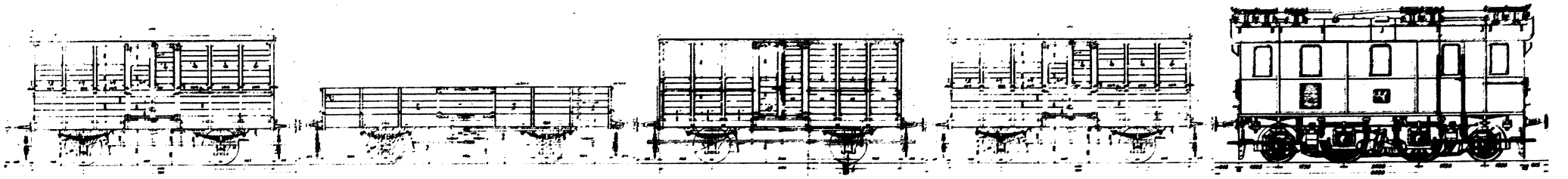

TFJ, Thisted-Fjerritslev Jernbane, blev åbnet for trafik den 19. november 1904. Fra starten havde man 4 damplokomotiver, (ex. DSB litra P), 6 personvogne, 2 person- og postvogne, 2 pakvogne, 2 rejsegodsvogne, 8 lukkede og 12 åbne godsvogne, alle bygget hos Vulcan i Maribo, og 1 sneplov fra Scandia, Randers. Dette materiel blev senere udvidet, damplokomotiverne var fra starten for små, de blev udskiftet med større maskiner ligesom vognparken blev forøget og fornyet. I 20' og 30'erne anskaffedes motormateriel og diesellokomotiver, og sidst i 40'erne kom skinnebusserne til. TFJ's vognpark var aldrig stor, sammenlignet med så mange andre privatbaner, men klarede i sin tid, til nedlæggelsen den 31. marts 1969, trafikken på bedste måde. Løvrigt kan vi henvise til artiklen om TFJ i Signalposten, 5. årgang (1969) nr 5.

JMJK, Jydsk Model Jernbane Klub, har i dette hæfte samlet størstedelen af de tegninger fra TFJ, som ikke tidligere har været offentliggjort. Blandt de tegninger, som det ikke lykkedes at fremskaffe kan nævnes damploko nr 5 - 8 samt enkelte godsvogne. Øvrige tegninger som ikke er medtaget i dette hæfte er TFJ 1-4 (ex DSB litra P) Sm 6-8, Sp 10-12, Sb 20 (skinnebusmateriel) samt C 9 (fejlagtigt litereret C 2 hos JS og HgJK) kan købes hos Jernbanehistorisk Selskab. Endvidere har Signalposten udgivet et fotohefte (nr 3) med TFJ beskrevet i fotos. Enkelte fotos fra TFJ kan købes hos Jernbanehistorisk Selskab.

Beklageligvis er bygningstegningerne ikke af samme kvalitet som vogntegningerne, da vi her ikke har haft mulighed for at nedfotograferer originalmaterialet. Omstående materieloversigt er sandsynligvis behæftet med visse fejl, især godsvogne har det knebet med oplysninger om.

Vi vil gerne rette en hjertelig tak til hr Skov, Landsarkivet, Viborg, ing. Andersen, Scandia, K.K.Joensen, Frichs, T. og O. Jørgensen, Sjørslev, L.Ehlers, Aarhus, for deres medvirken ved dette heftes udgivelse. En speciel tak skal her rettes til C.A.Lindahl, uden hvis hjælp alt dette ikke havde været muligt.

Jernbanehistorisk Selskab:

Tegningsarkiv, Nørrebro St. 2200 Kbh. N giro nr 6125506
Fotoarkiv, Nørrebro St. 2200 Kbh. N, giro nr 125305
Signalposten, v. Ulf Holtrup, Dalbyvej 12, 2700 Brønshøj
giro nr 6491722.

Dette hefte er udgivet af Jydsk model jernbane Klub og kan købes for 30 kr ved at indsætte beløbet på giro nr 5457157, JMJK, Fredensgade 8, 8382 Hinnerup.

Aarhus, d. 19. november 1976

Kaj Stender Niels Jørgen Hansen

Materialoversigt:

Trækraft

Nr 1-4	1883	Esslingen, til TFJ 1904
Nr 5-8	1916-25	Henschel
M 1-2	1928	Triangel, M 2 til VBV 1969
ML 3	1936	Frichs
ML 4	1953	"-", opr. HV DL 100, 1962 til TFJ, 1969 til HP 14.

skinnebusmateriel

Sm 4 - 5	1948	Scandia
Sm 6	1952	"-", opr. HJJ Sm111, til TFJ 1957
Sp 10-11	1948	"-
Sp 12	1952	"-", opr. HJJ Sp 321, til TFJ 1957
Sb 20	1956	"-

personvogne

B 1-4	1904	Vulcan
C 1-2	"-	"-
C 3-4	1906	Scandia
C 5-6	1910	"-
C 7-8	1934	"-", C 7 til DJK 1969
C 9	1943	"-

post- og personvogne

D 1-2	1904	Vulcan, senere D 11-12, D 11 til DJK og oph.
D 3	1932	Scandia, senere Ce 13.

rejsegodsvogne

E 1-2	1904	Vulcan, senere E 21-22
Qs 1-2	1904	"-", senere E 23
H 1-2	1910	Scandia, senere H 41-42

godsvogne

Q 1-4	1904	Vulcan
Q 5-6	1914	Scandia
Q 11-14	1906	"-
Q 15-18		
Q 19-20	1908	Arlöf
Q 21-22	1910	Scandia
Q 23	1914	"-
Q 61		
Q 93		
I 100	1885	Atlas, opr. DSB Za 9821, senere Za 99521
I 101		1946 til TFJ, 1969 til HgJK.
I 103		
K 1-2	1904	Vulcan
K 3-4	1906	Scandia
P 1-5	1904	Vulcan
P 6-15		Scandia ?
Pl 11-15	1904	Vulcan
Pj 15-16	1942	Scandia
sneplov 1	1904	Scandia
sneplov 2	1942	"-

MOTORVOGN-39 SIDDEPLADSER

SKALA-1:20

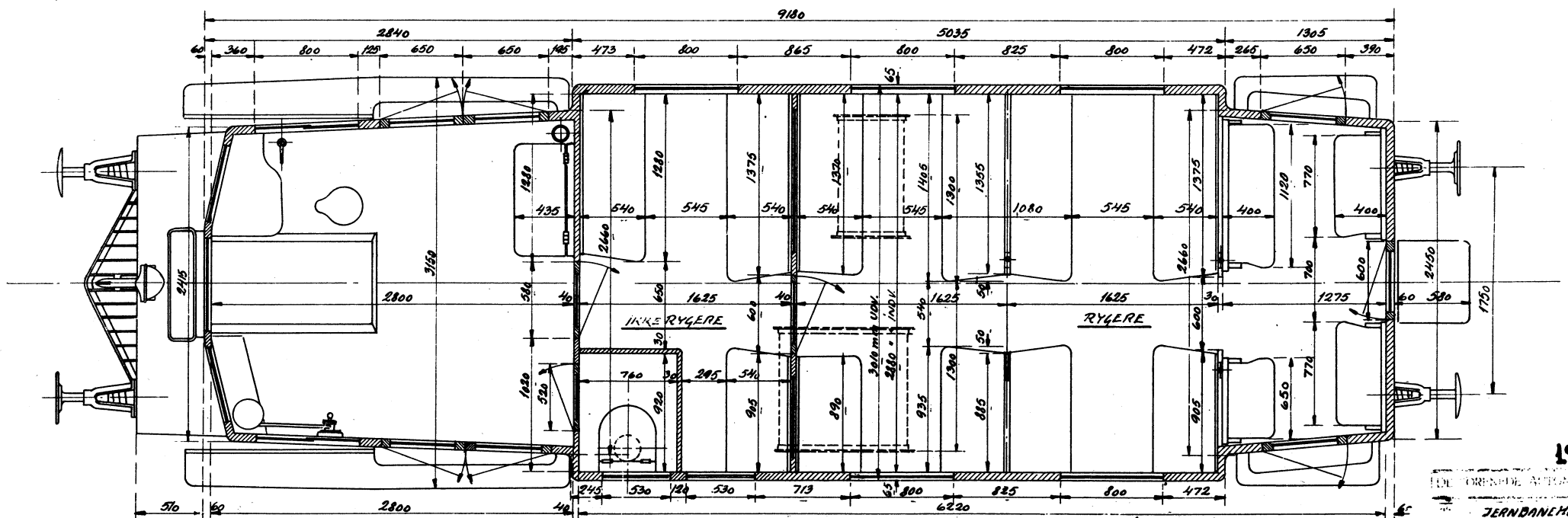
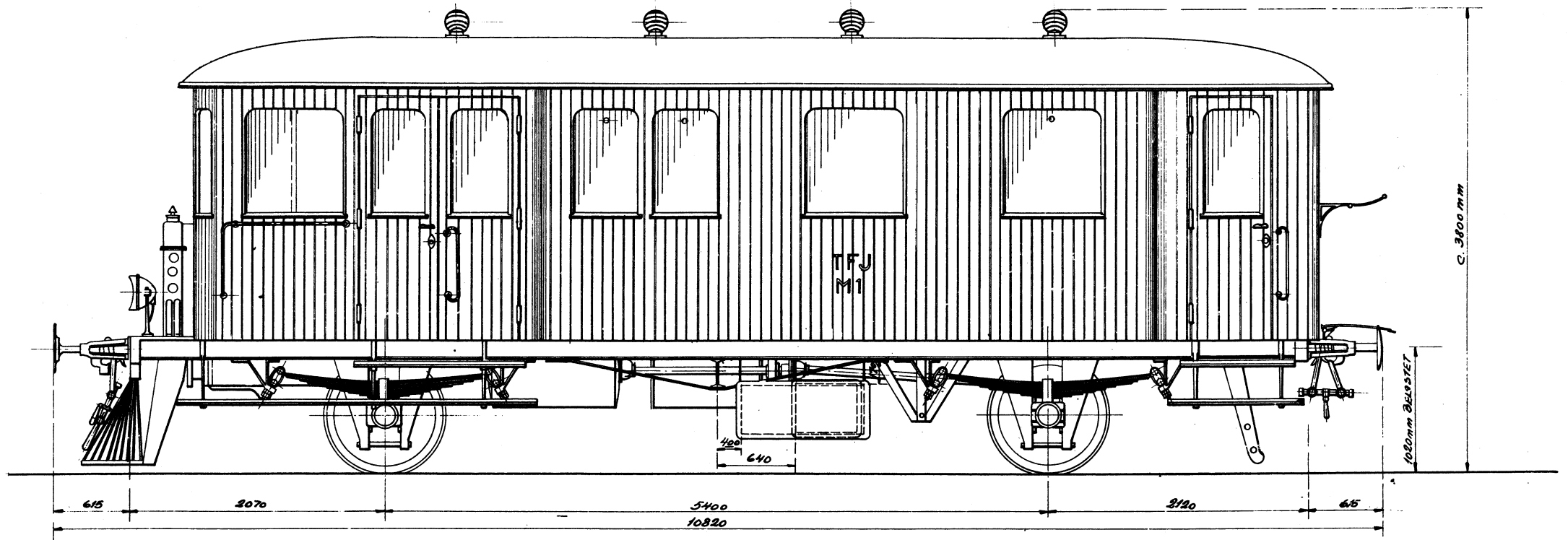

1927

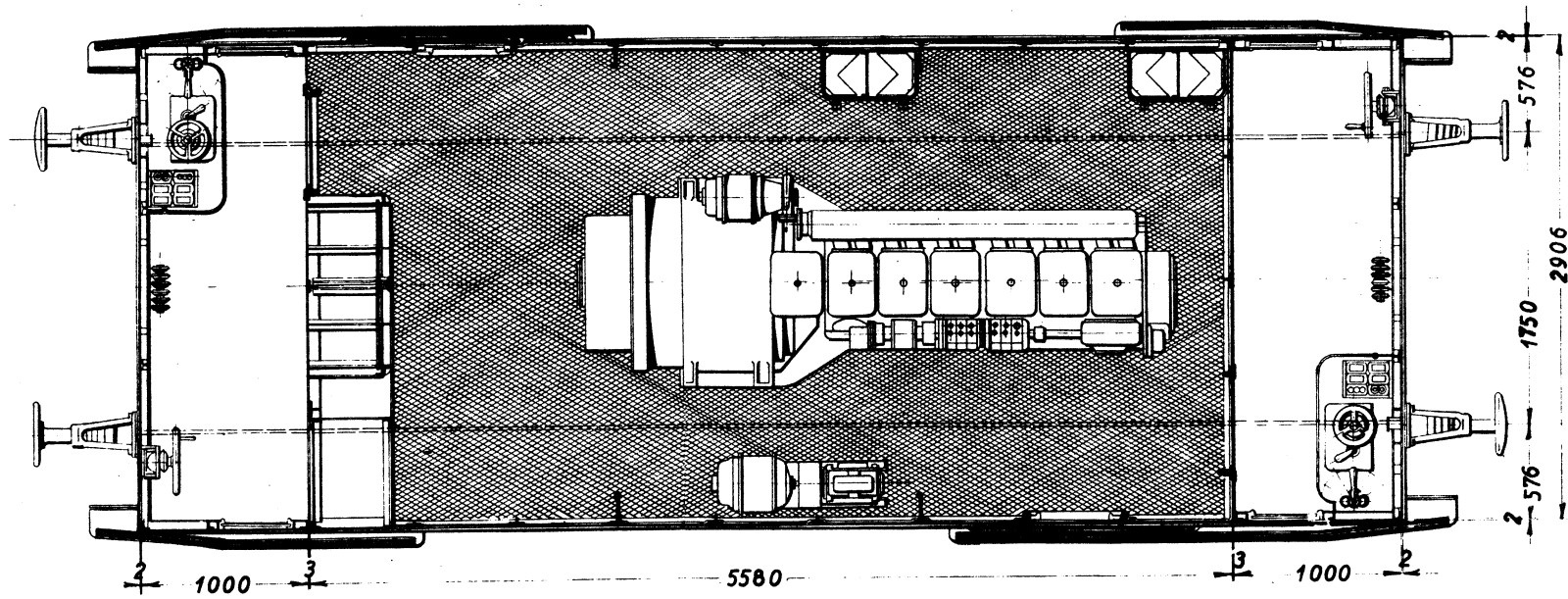
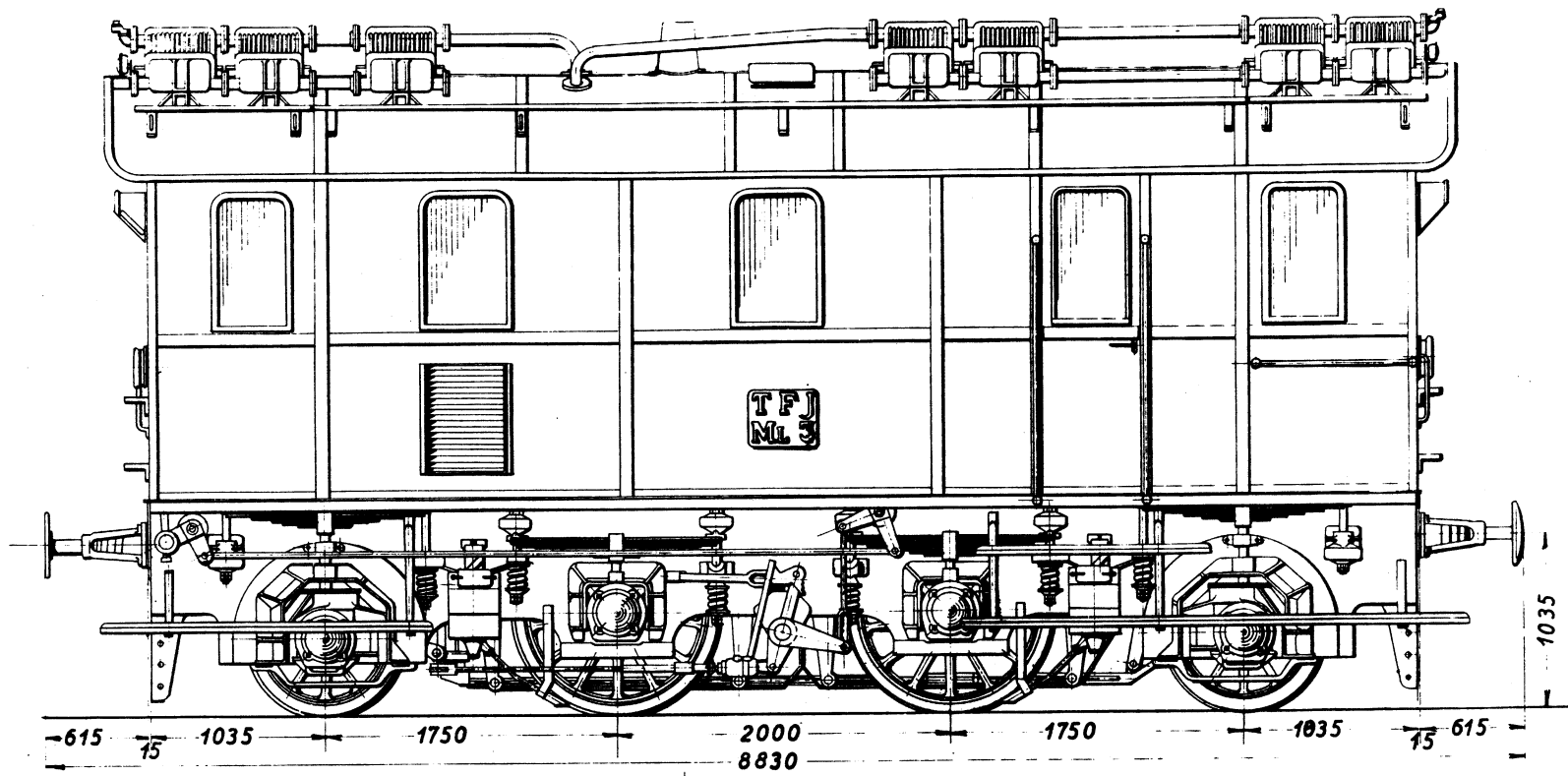

TFJ ML3 1936 FRICHS nr 252

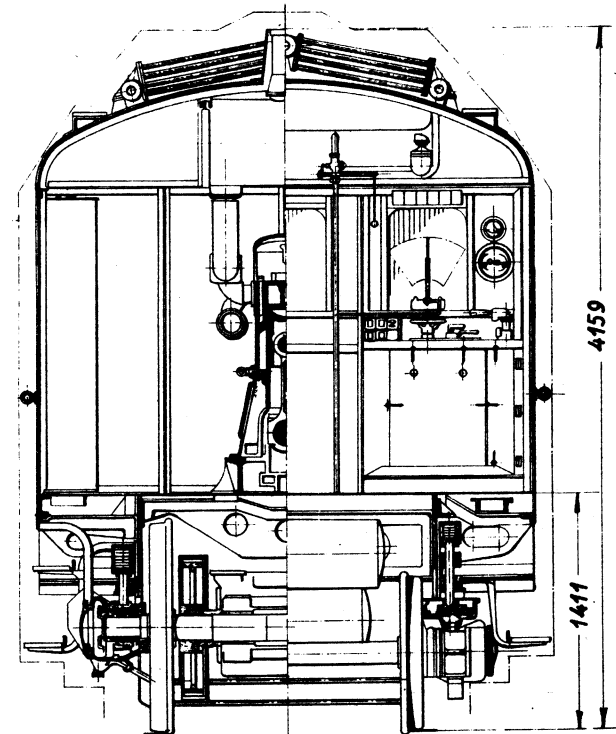
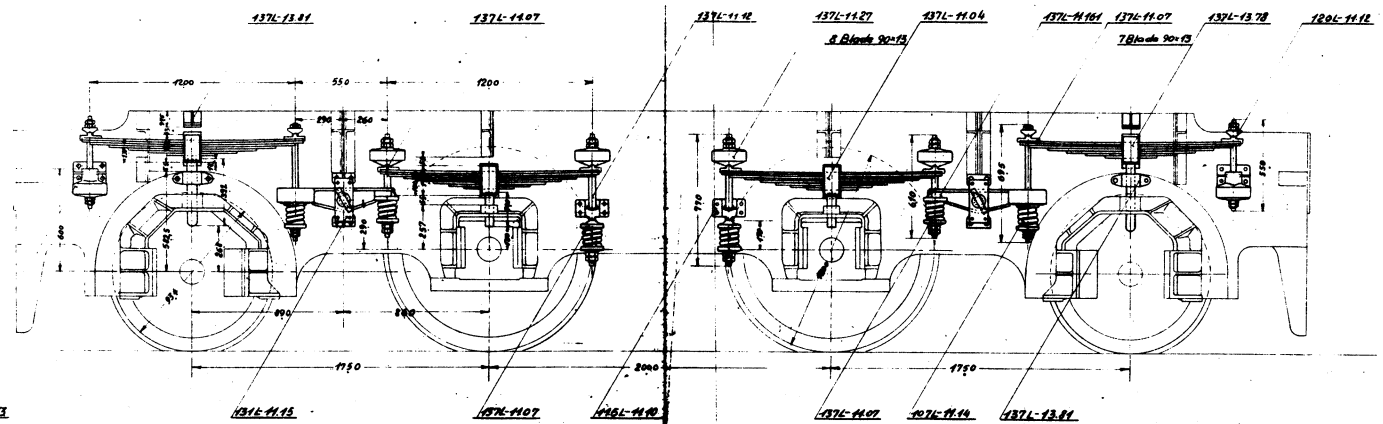
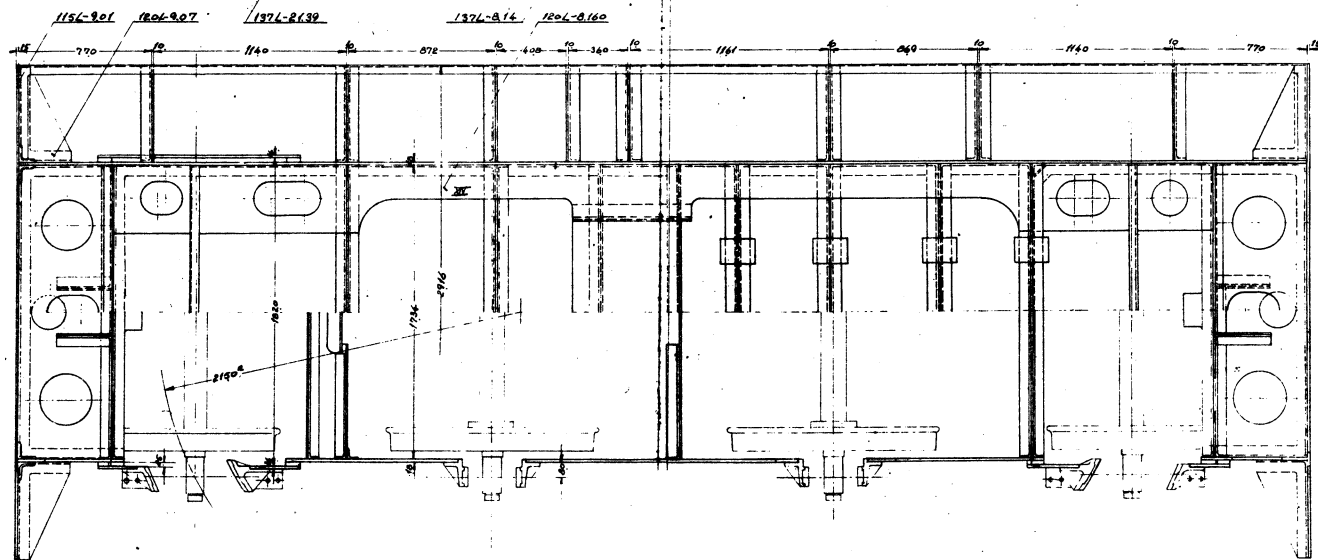
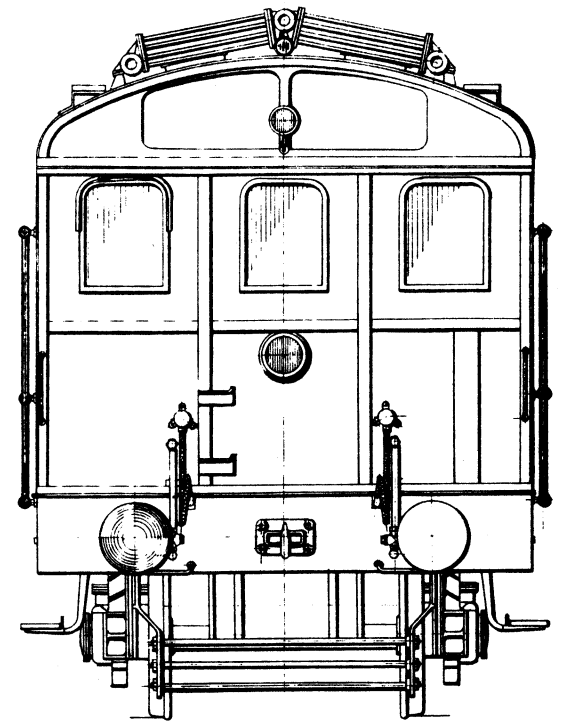
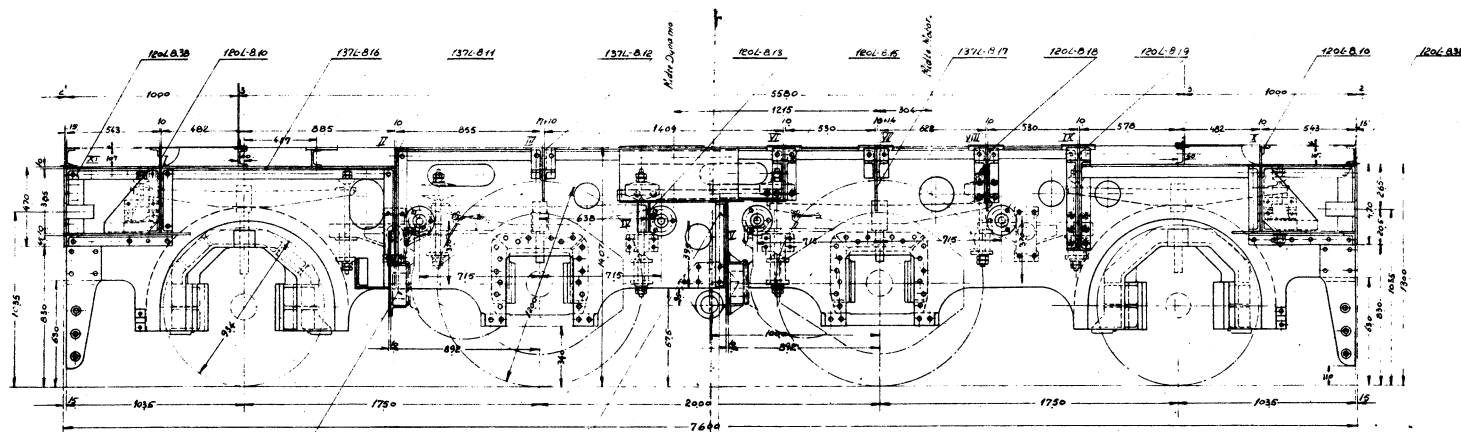

TFJ ML 3

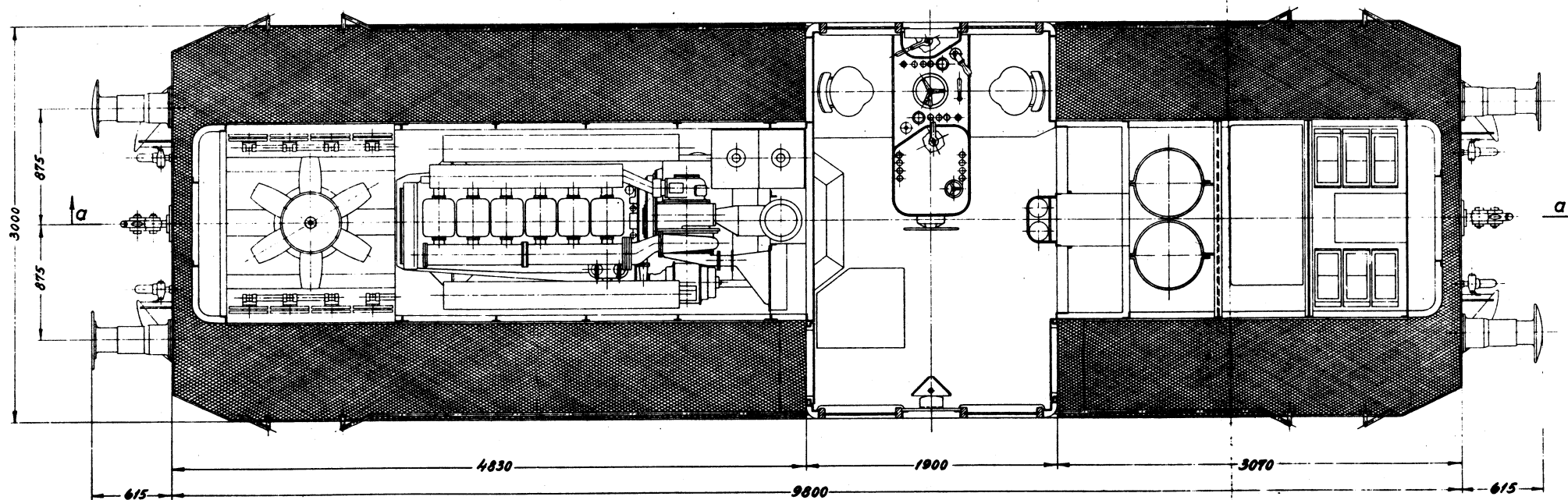
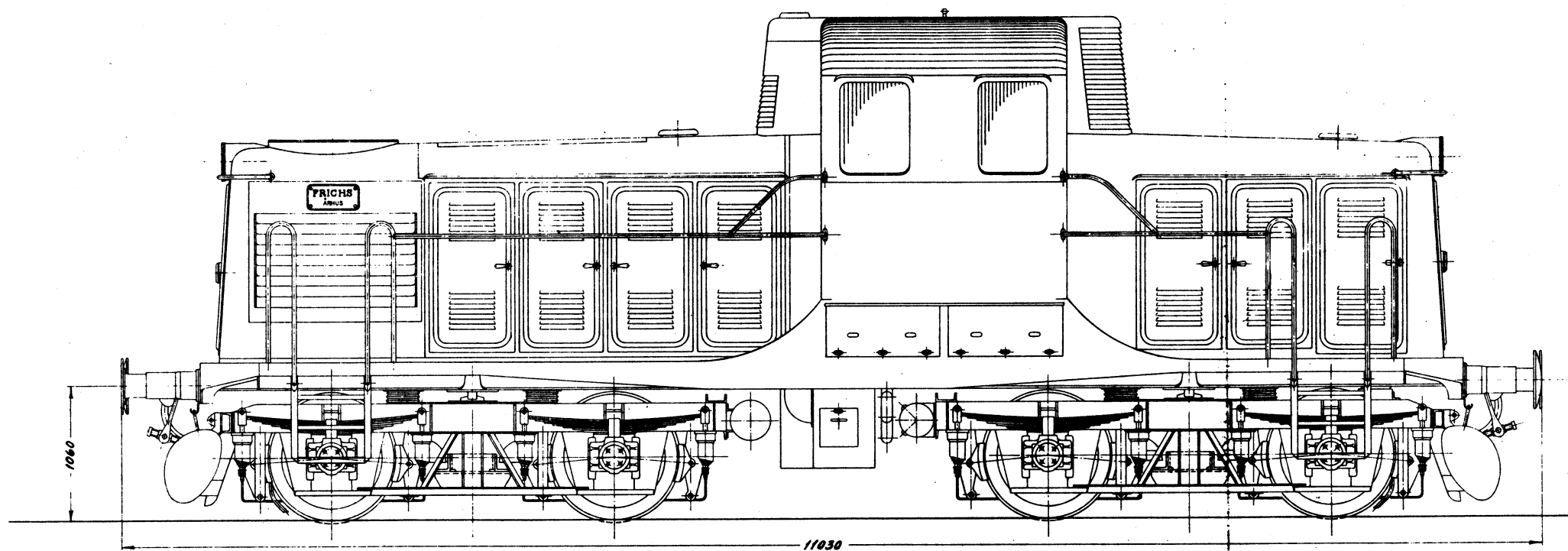

TFJ ML 4 1953 FRICHS nr 476

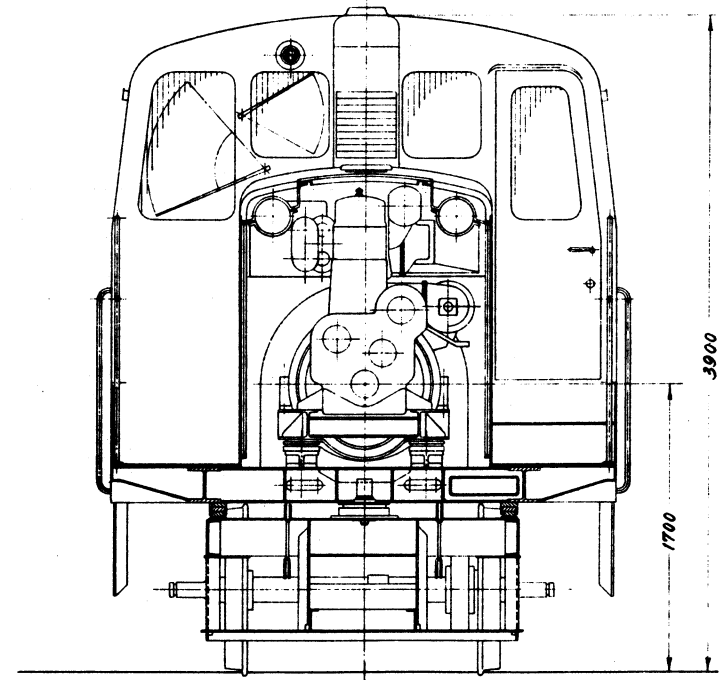
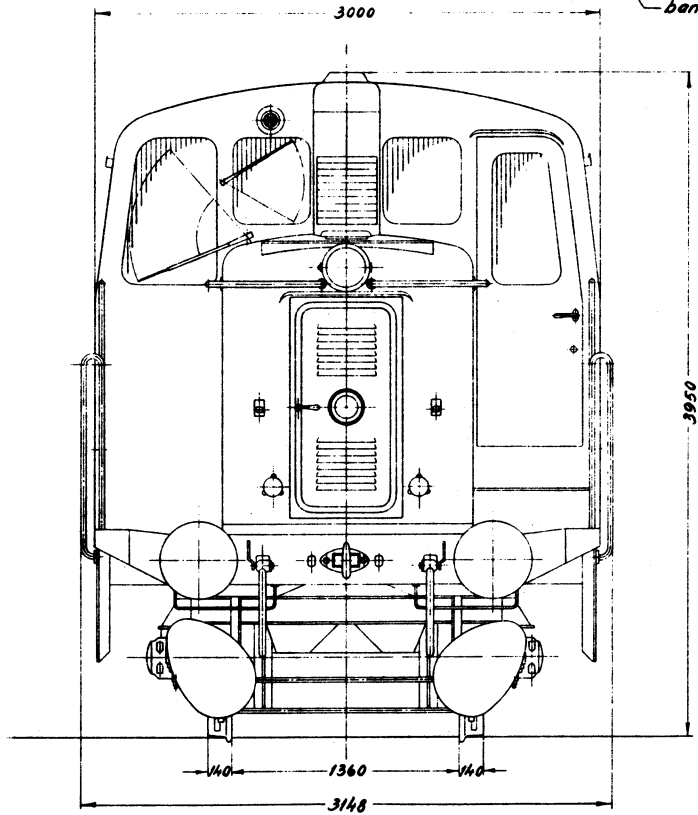
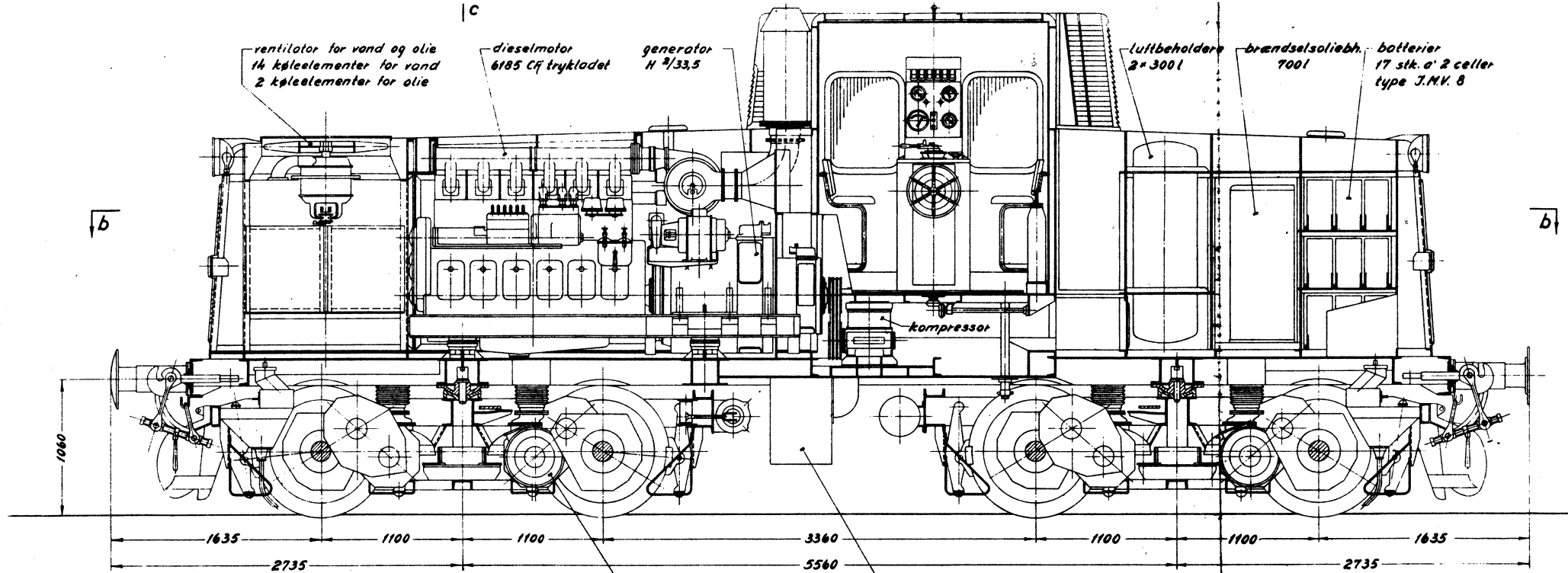

TFJ ML 4

II og III del Personvogn

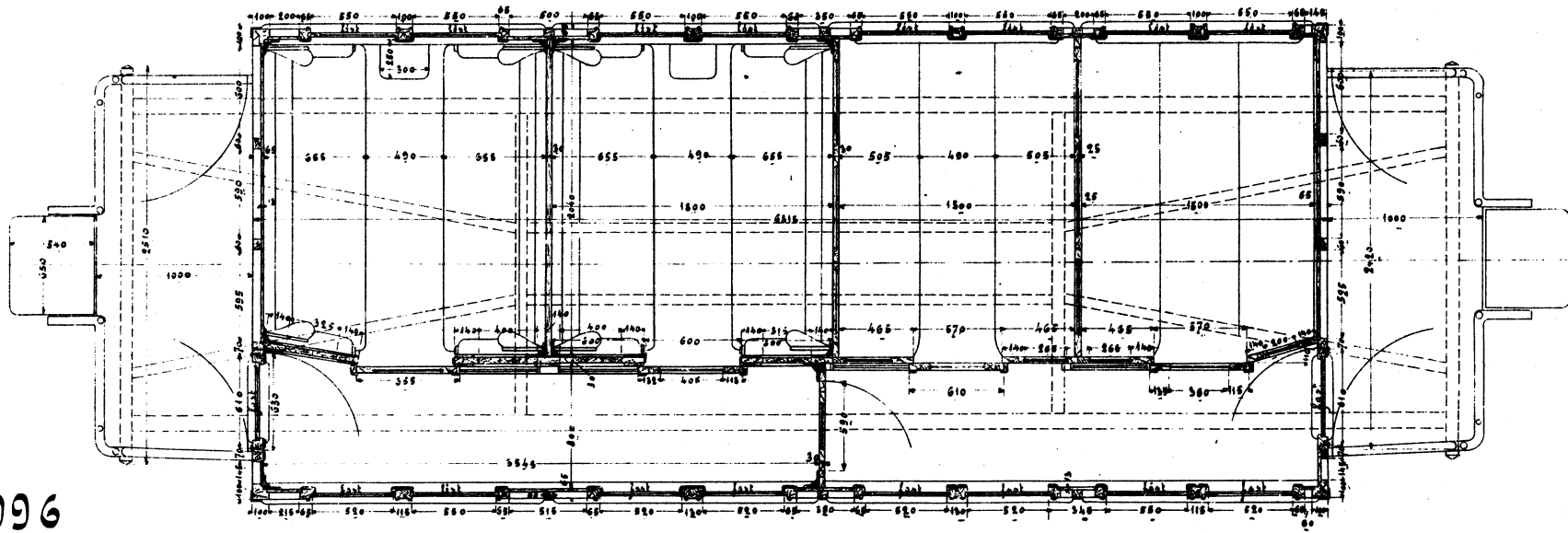
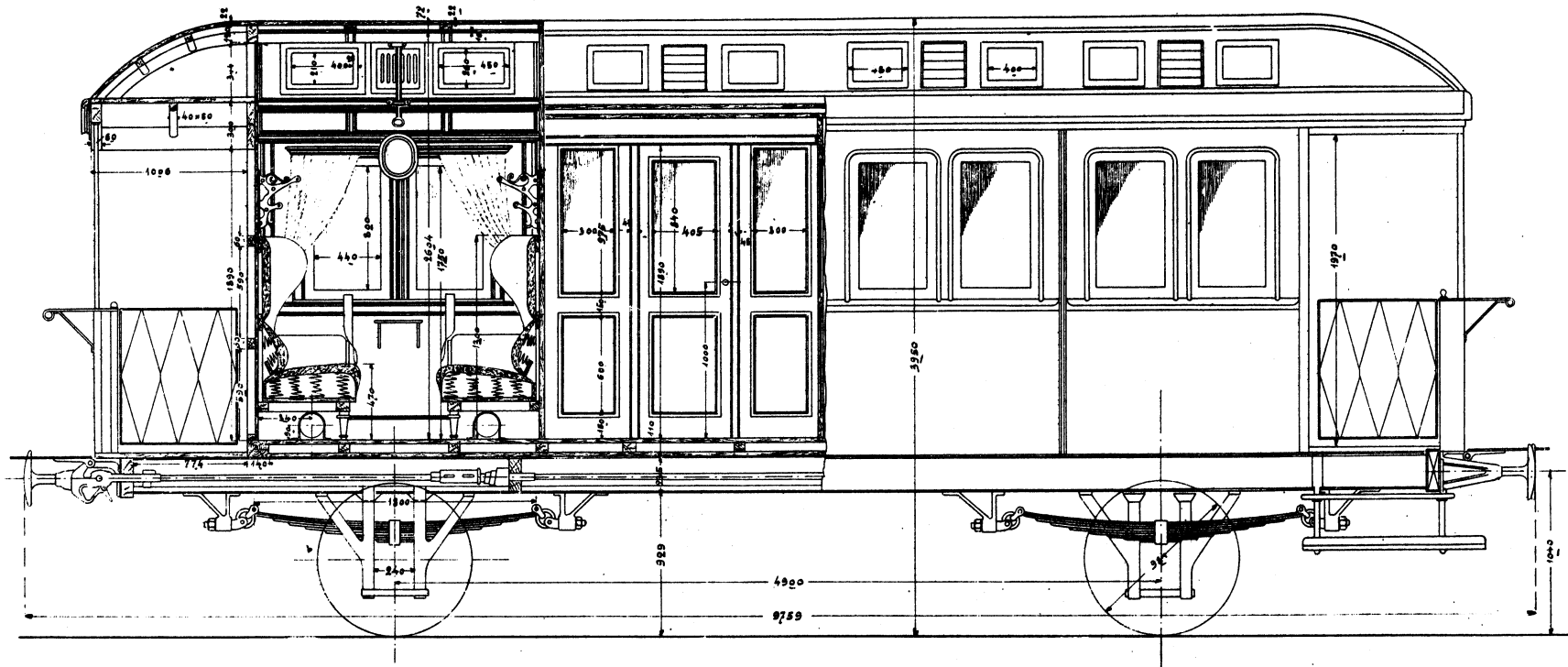

996

TFJ B1-4 1904 VULCAN

III Kl. Personvogn.

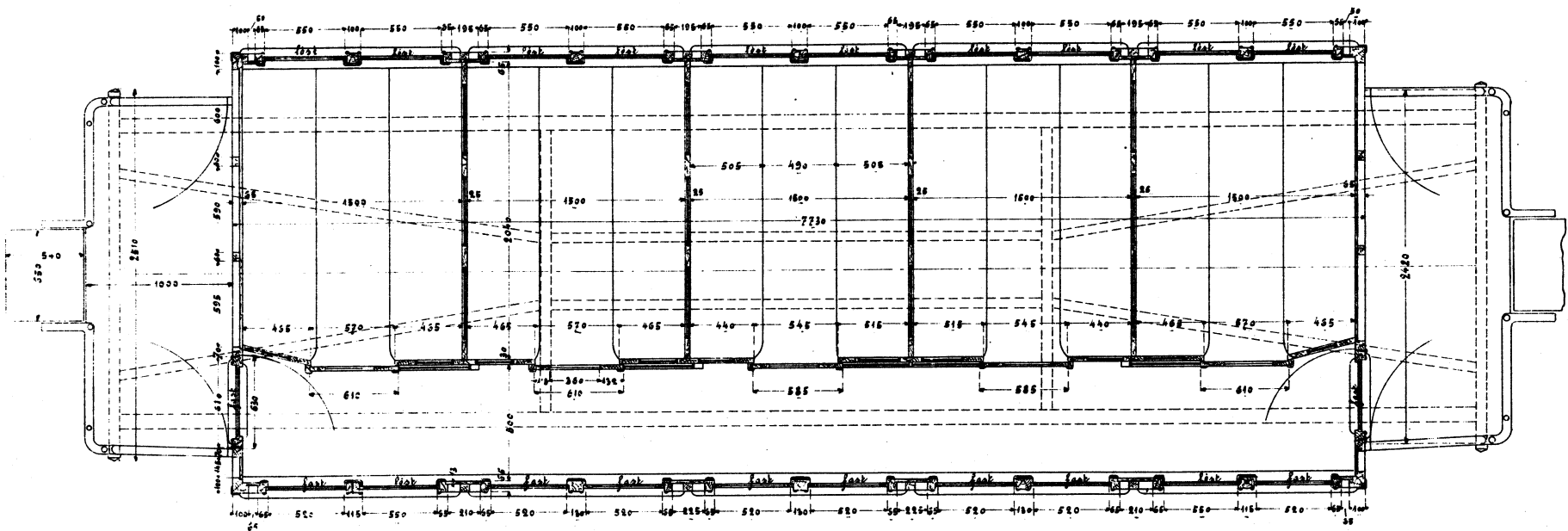
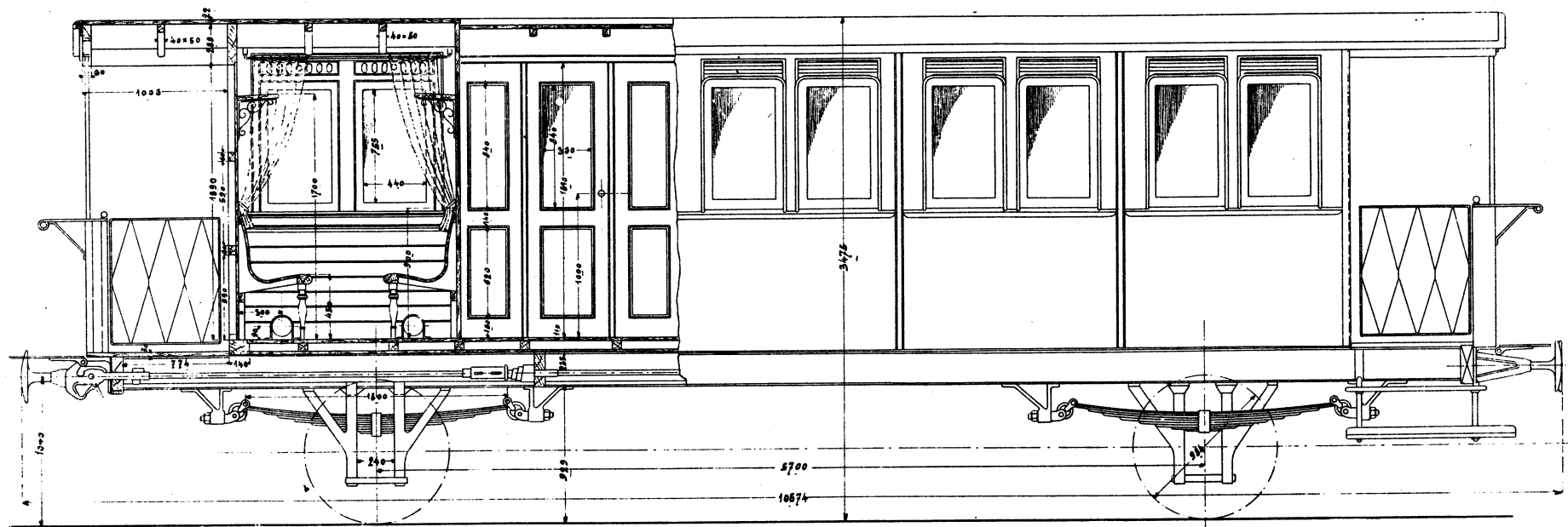

1000

TFJ C1-2 1904 VULCAN

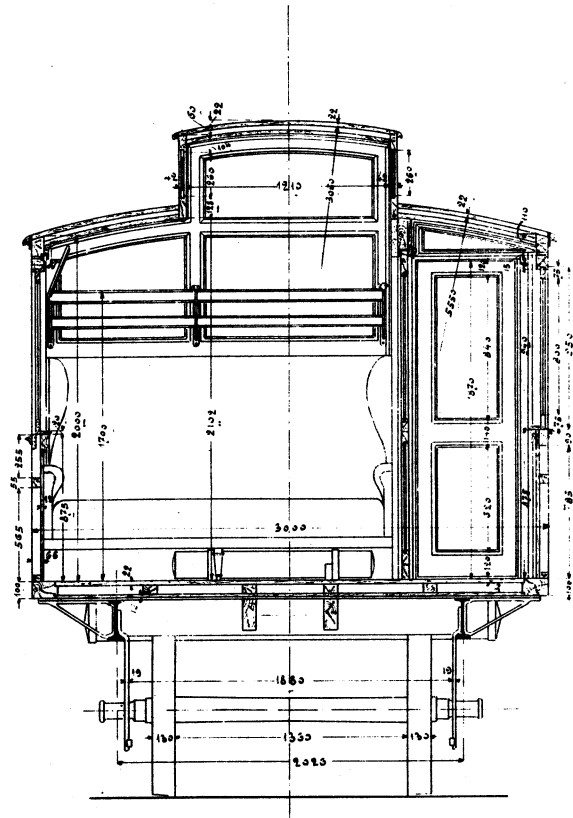

TFJ B1-4

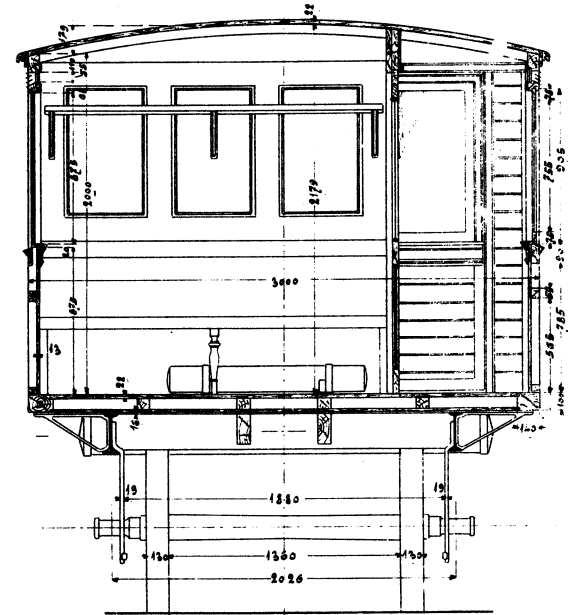

TFJ C1-2

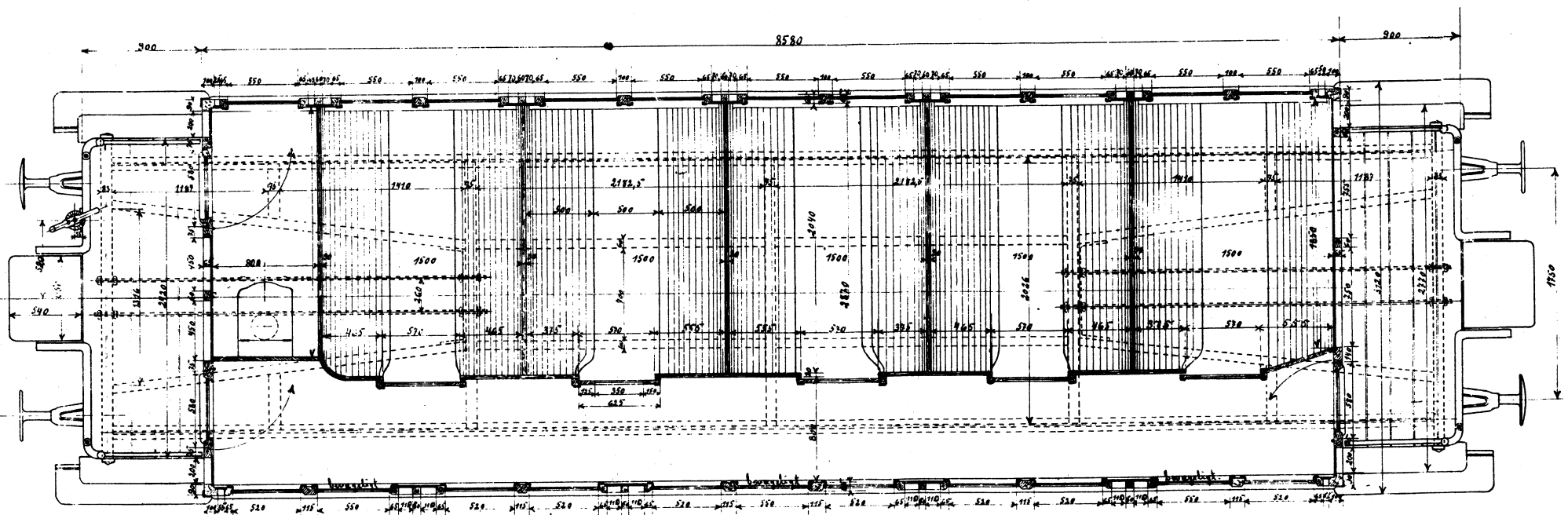
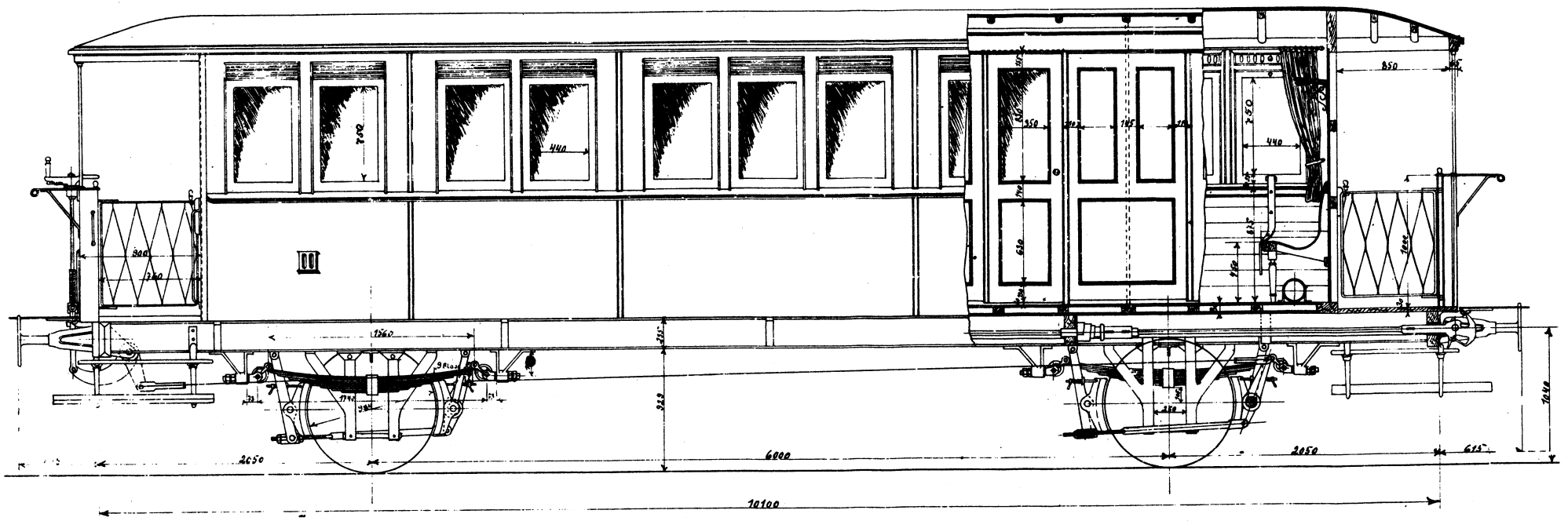

TFJ C 3-4 SCANDIA 1906

№ 8908.

Scandia i Randers.

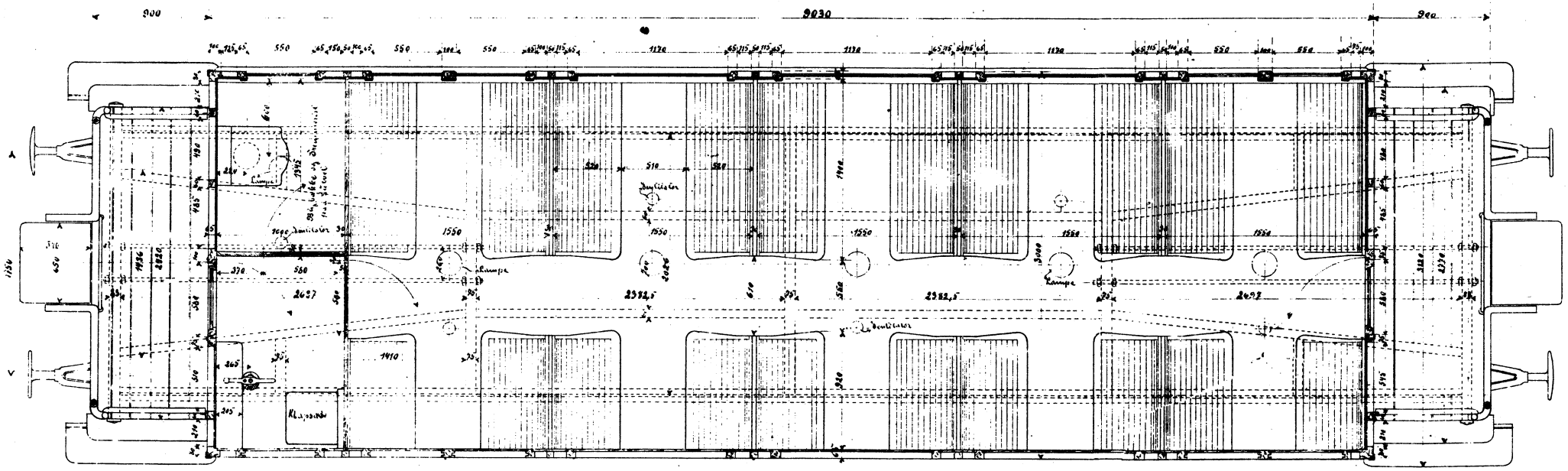
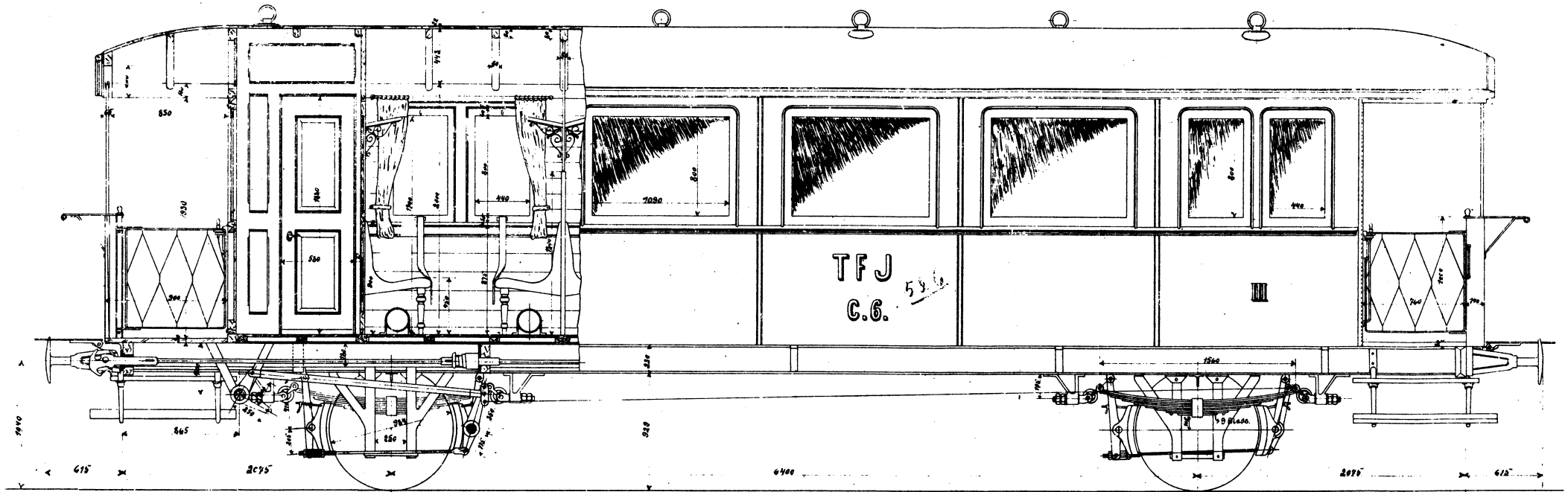

TFJ C 5-6 SCANDIA 1910

En 2. og 3. vogn 10870 Hg.

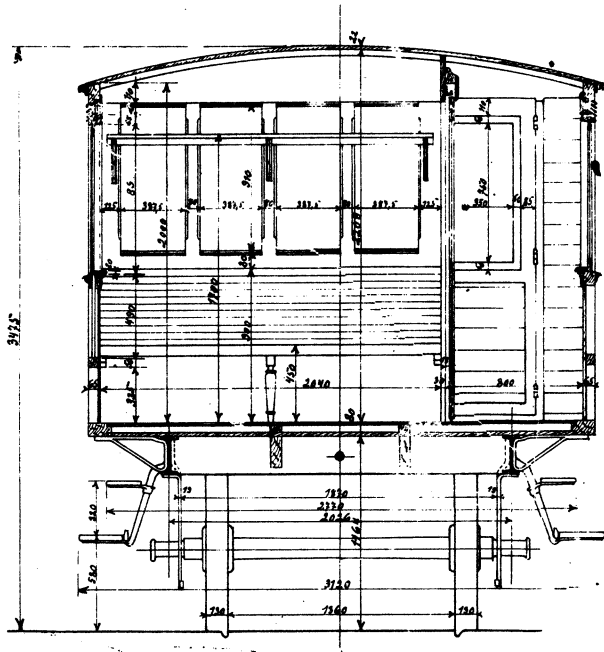

TFJ C 3-4

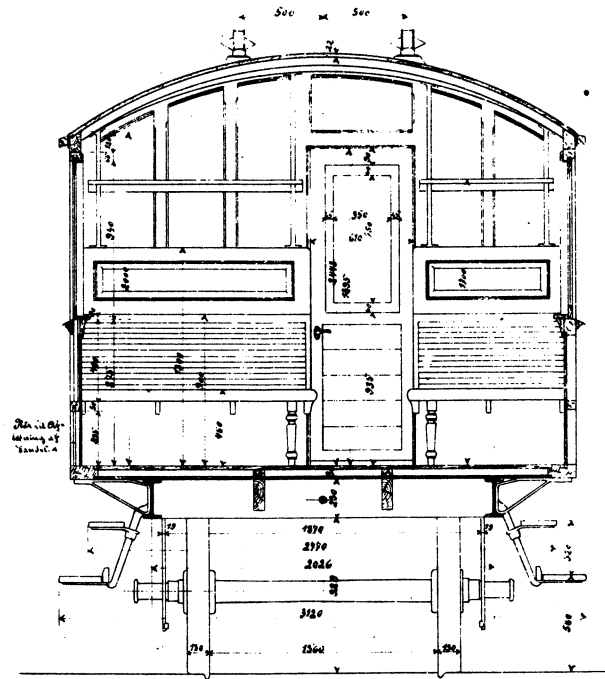

Personvogn III Klasse
 til
 Thisted - Fjerritslev. Banen.
 Ordre 626.

Leen 1/5 1906

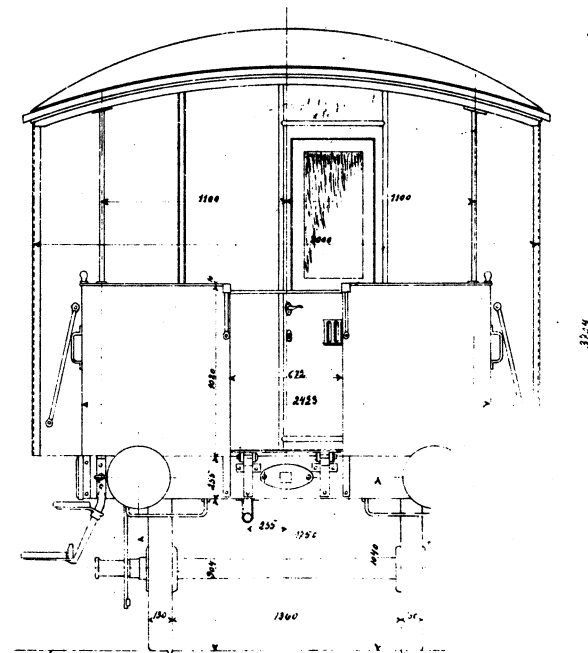

TFJ C 5-6

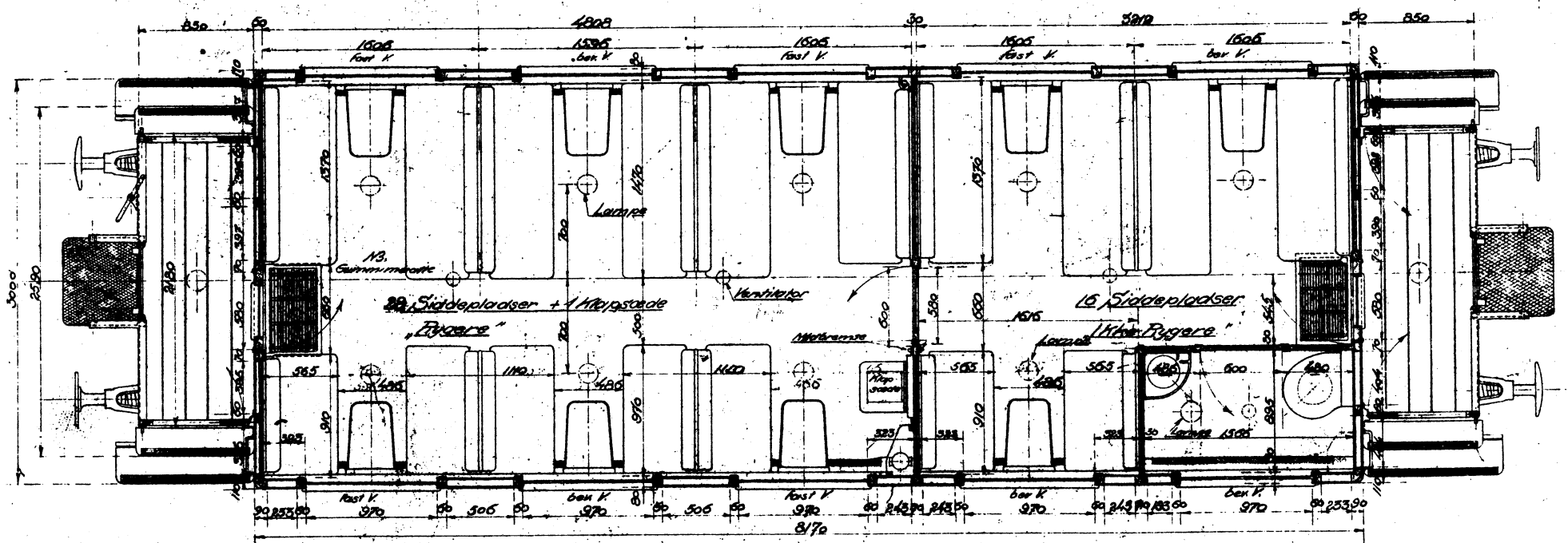
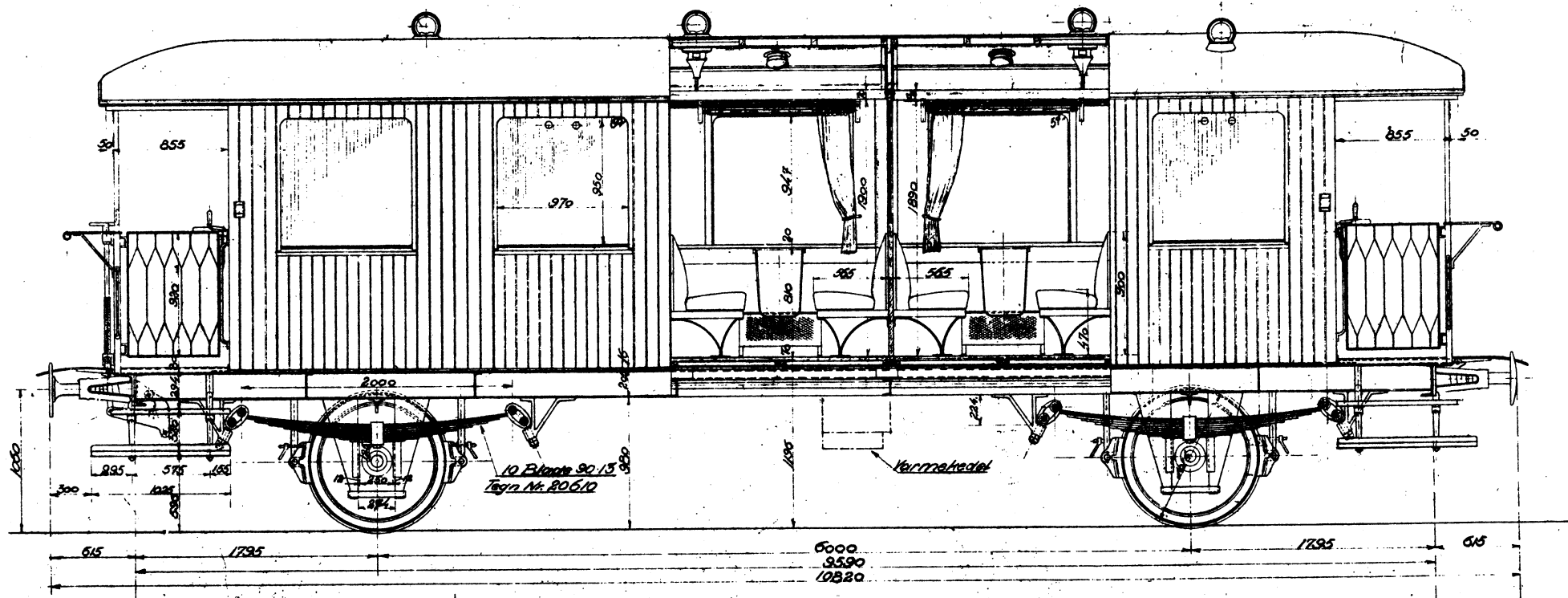

TFJ C 7-8 1934 SCANDIA

Bost og III 3kl Personvogn

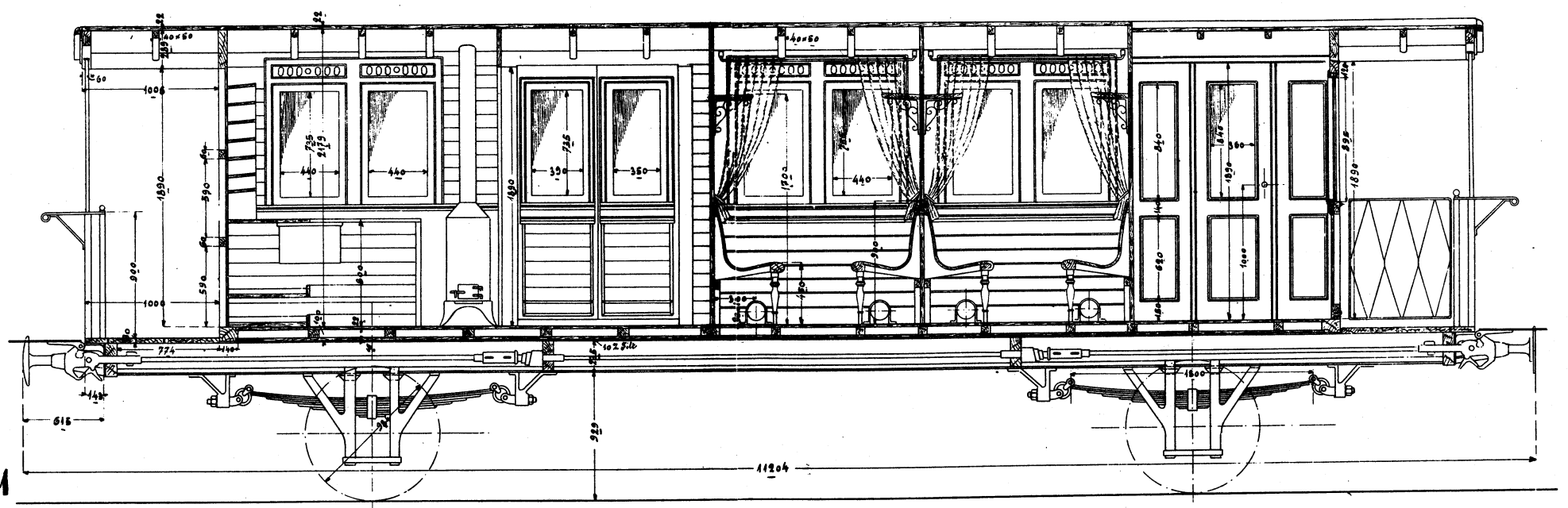
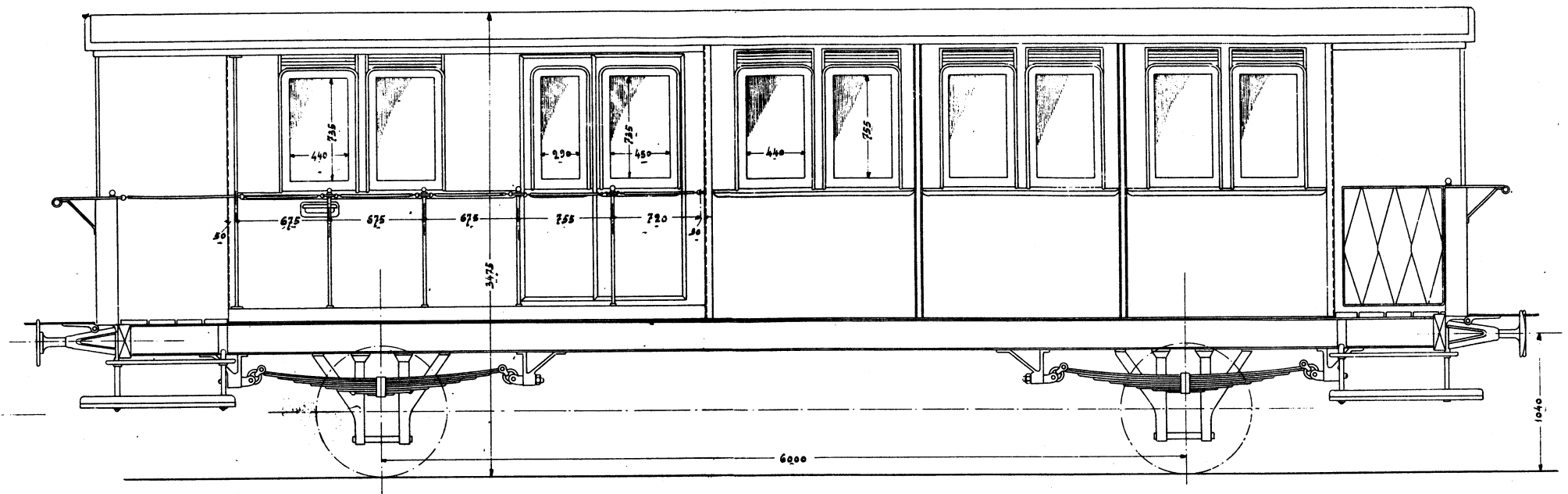

1001

TFJ D1-2 1904 VULCAN

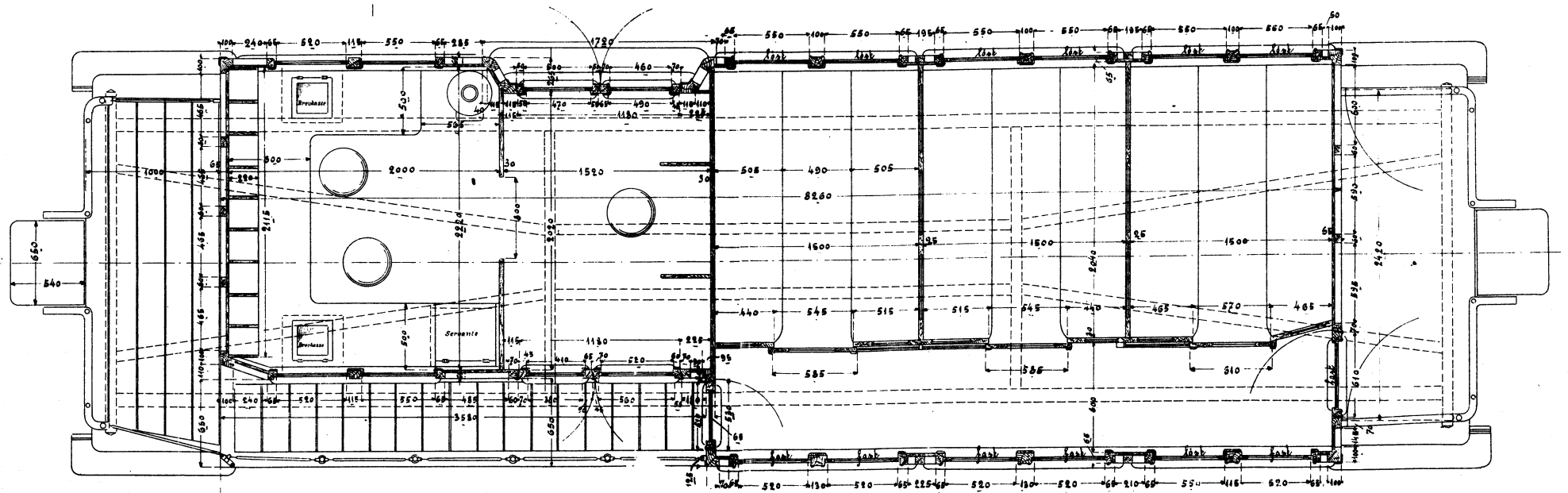
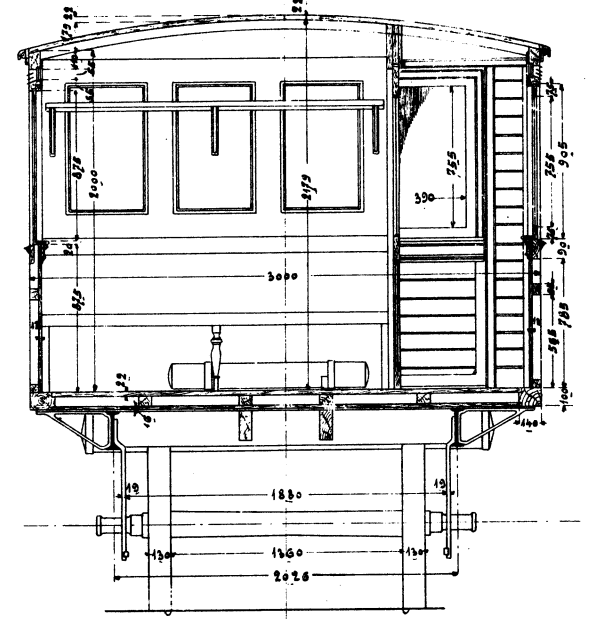
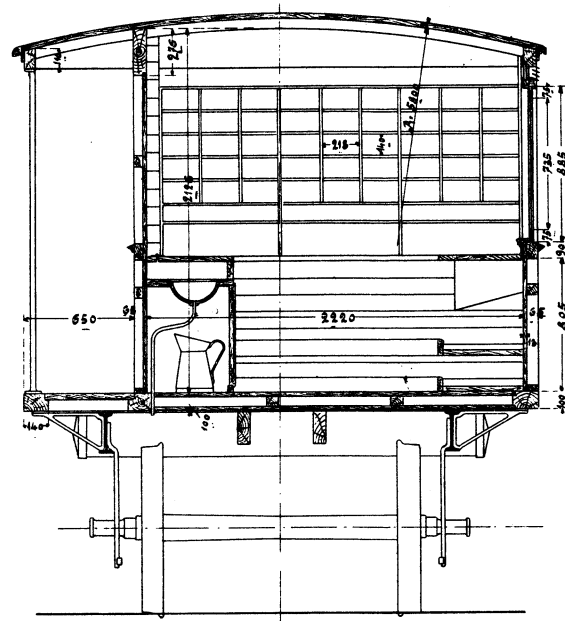
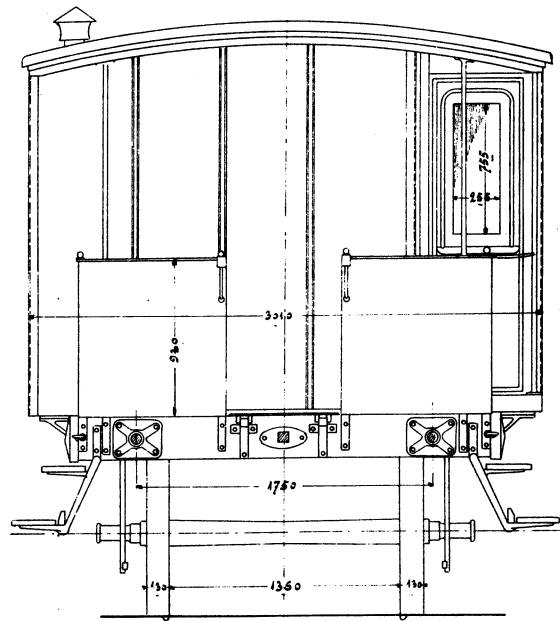

TFJ D 1-2

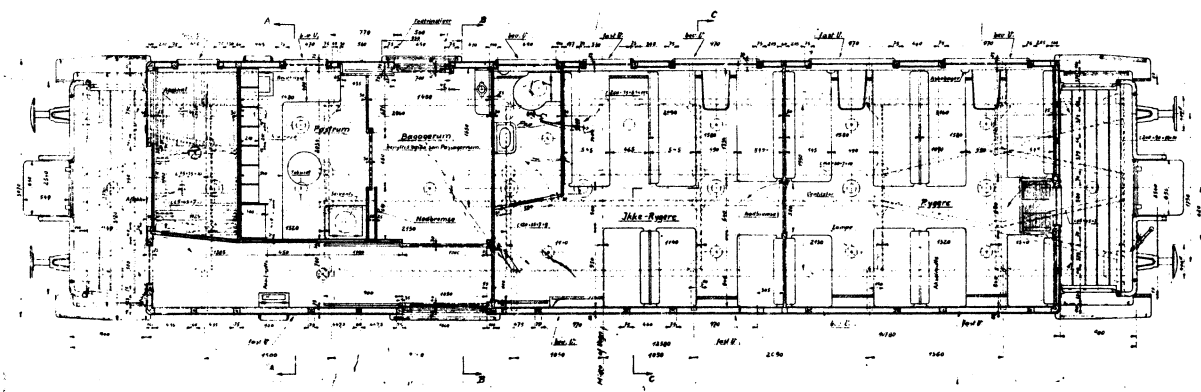
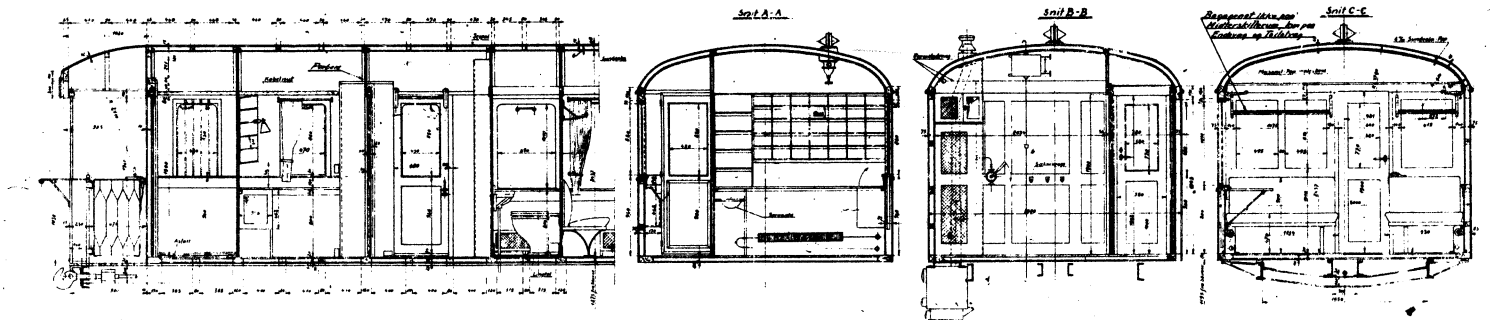
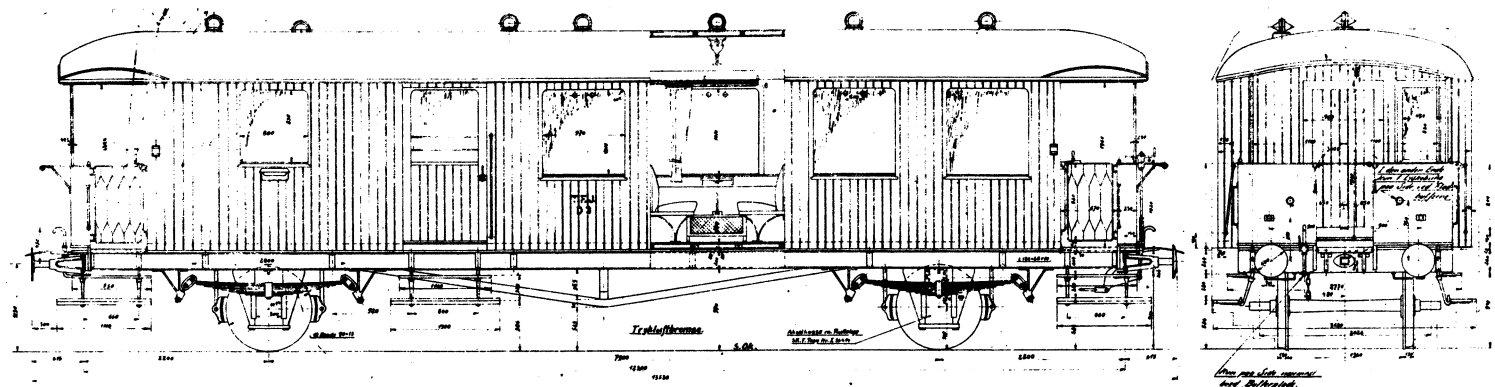

38 Sidsædepladser.
 Pland 1:20
 Post og Personvogn.
 Thisted Fjernstjer Bane?
 Ordre 2703
 Nr. 19288a

Bagage og Varmekedelvogn

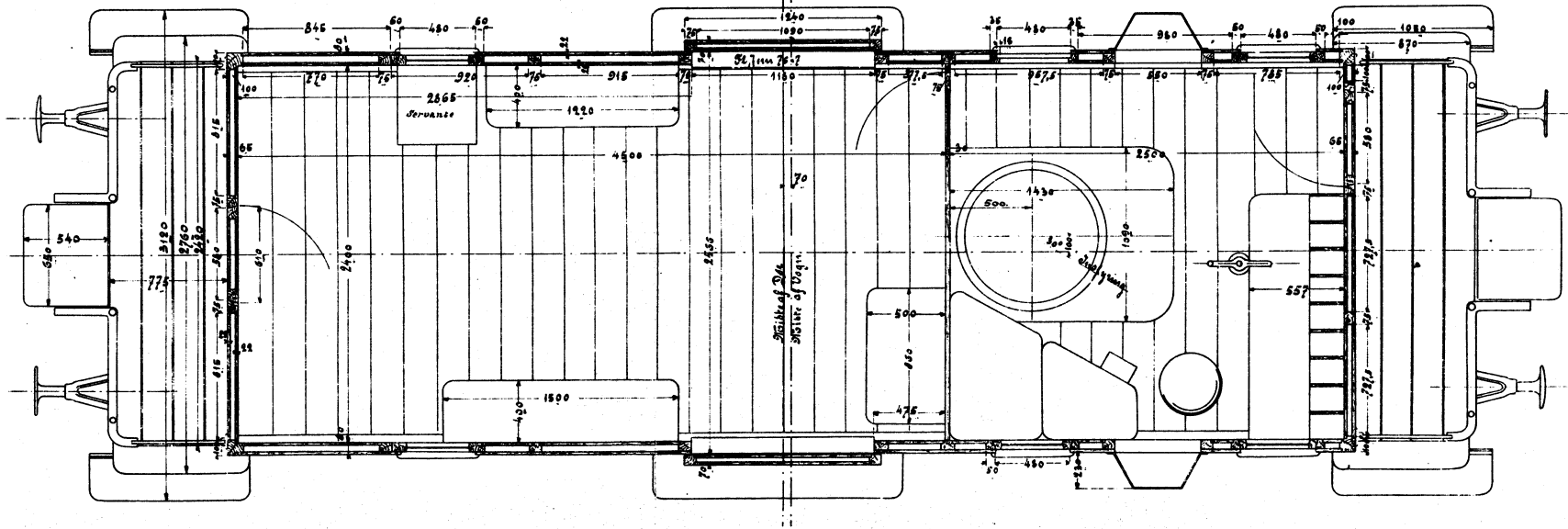
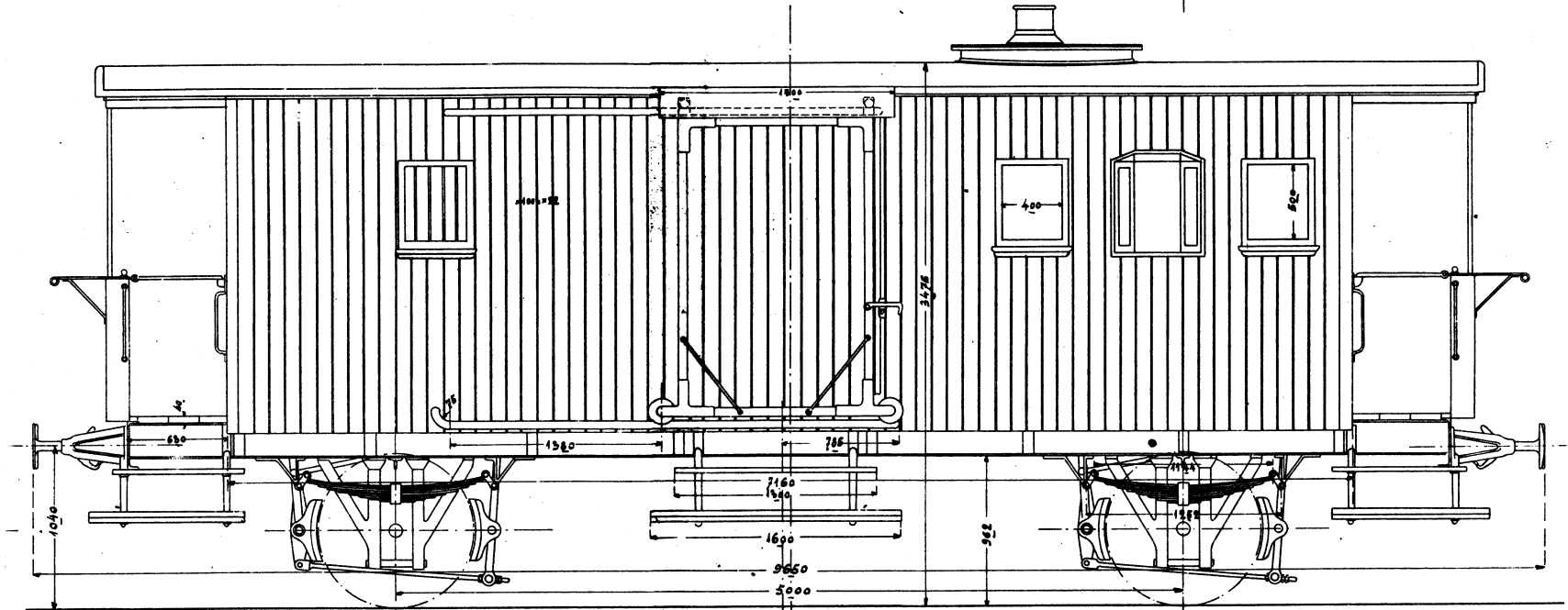

1004

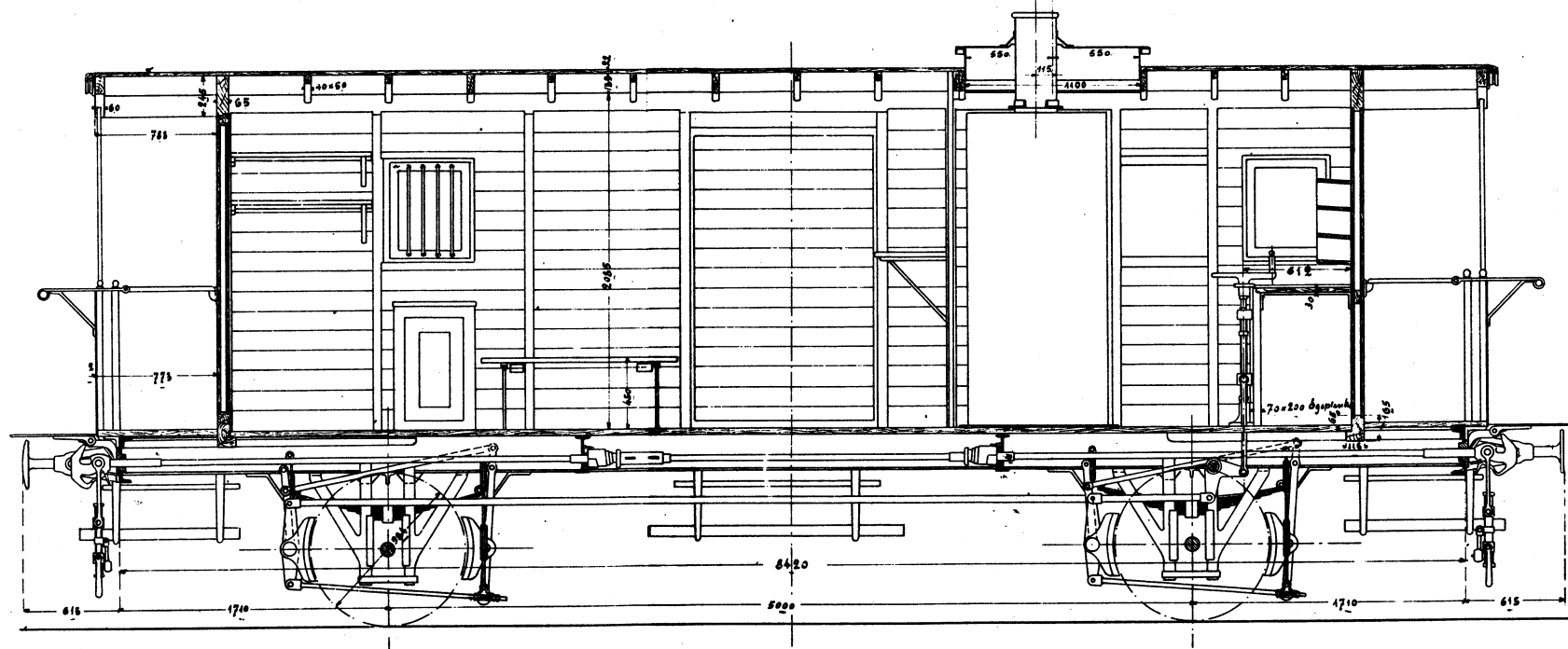
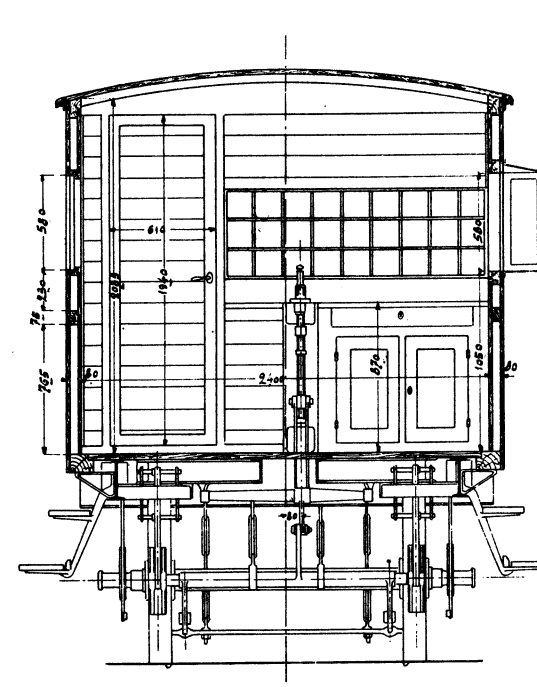
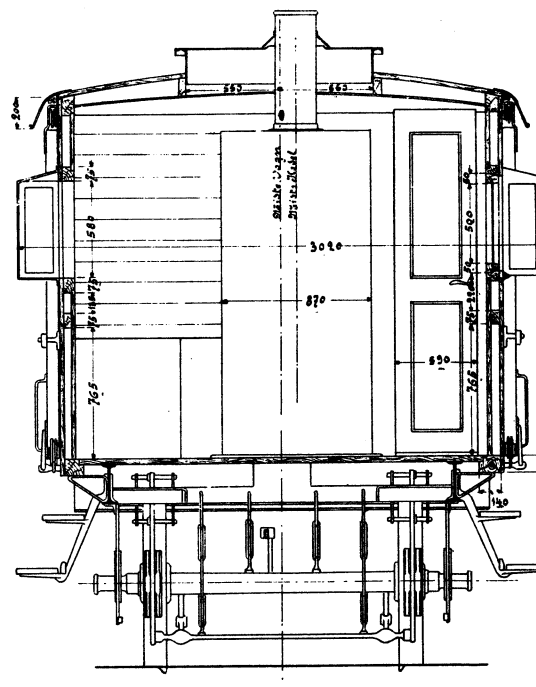
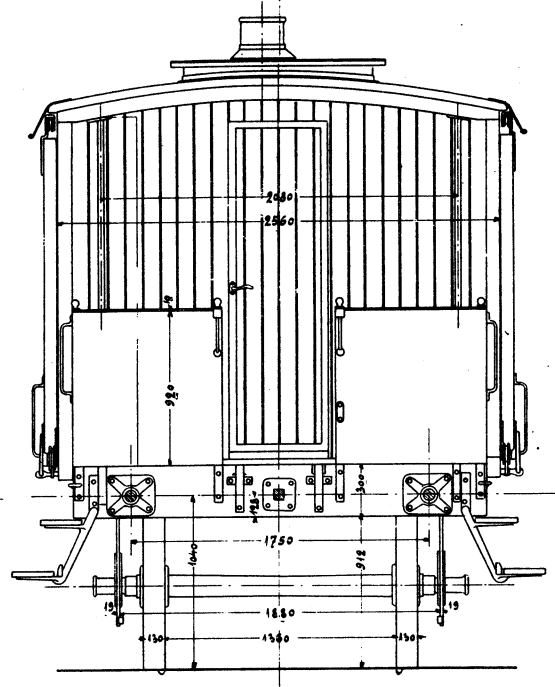

TFJ E 1-2

No 9299.

Scandia i Randers.

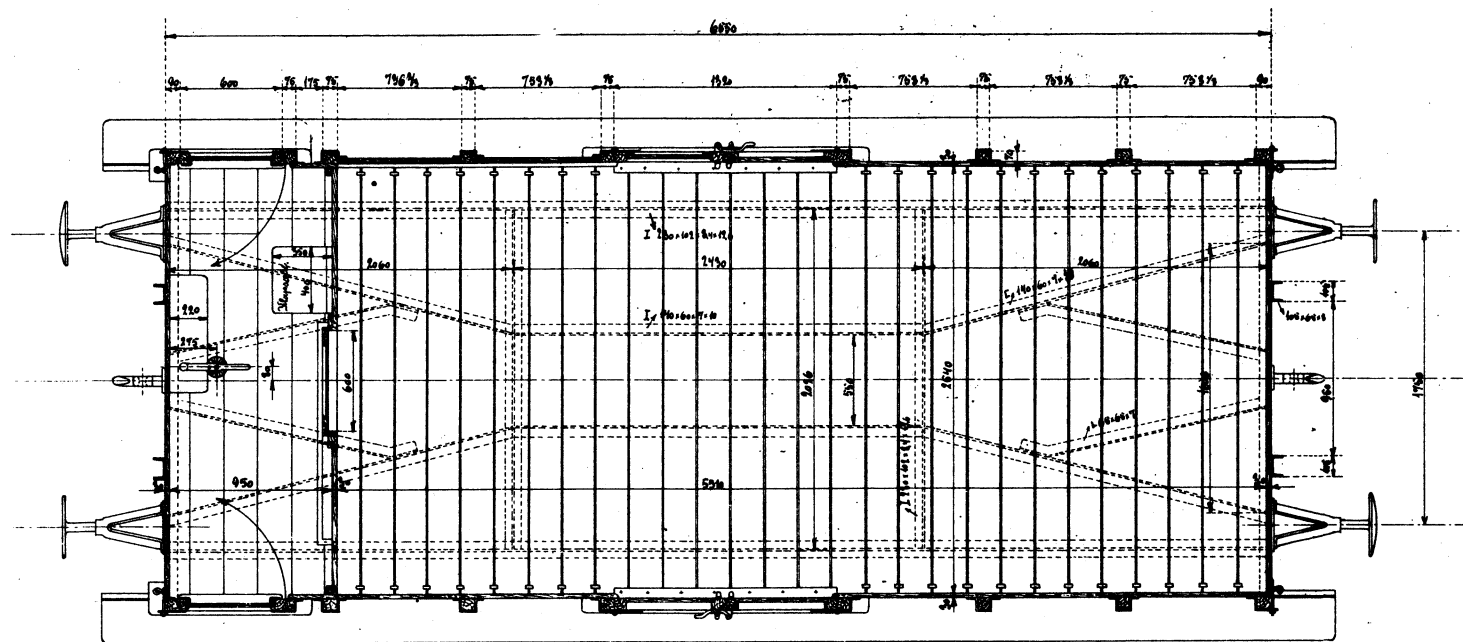
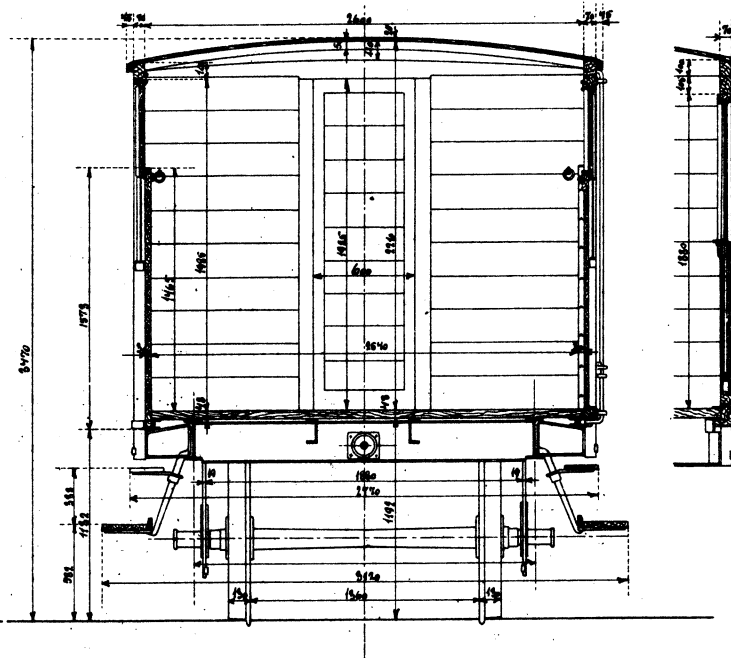
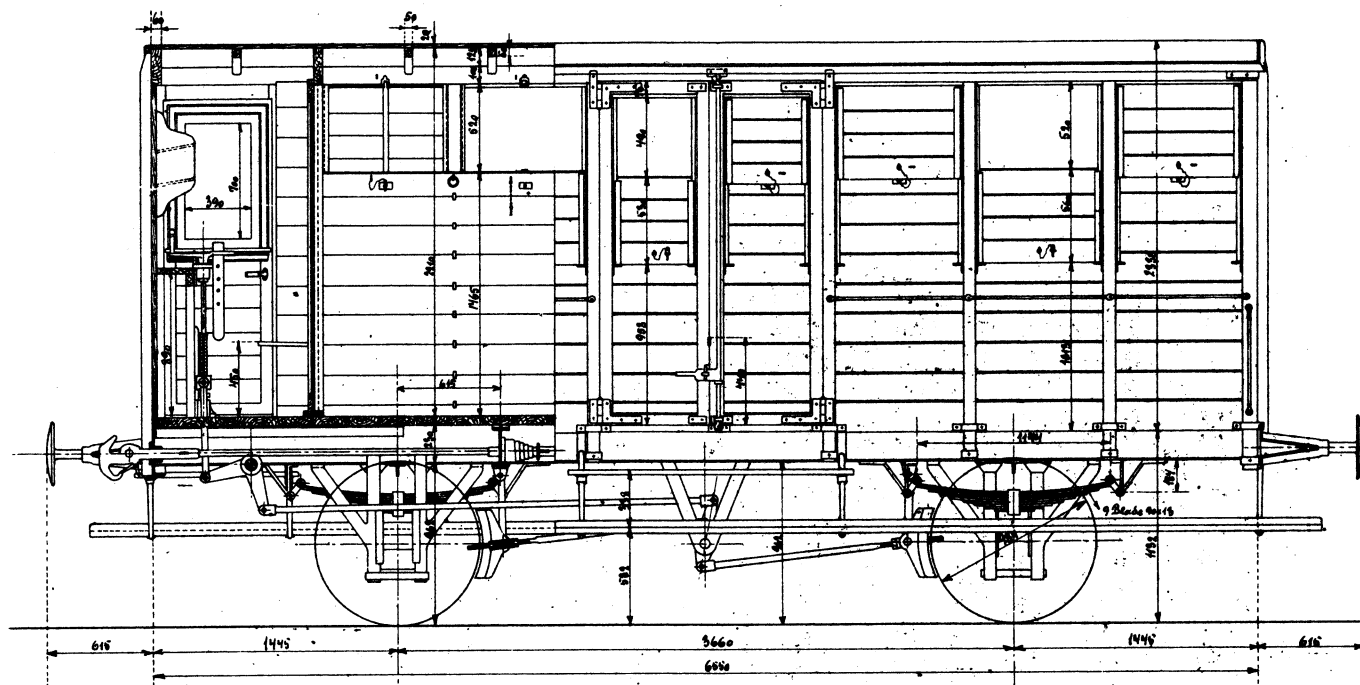

Lukket Godsvogn med Bremseskive
til
Skisted - Bjerritslev - B. n. n.
Vægt = 7335 Kg.

Scandia 24-10-10

TFJ H 1 - 2
SCANDIA 1910

Вагону.

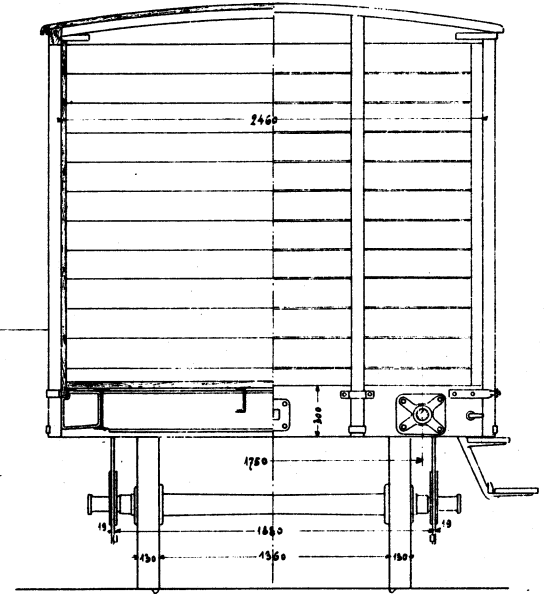
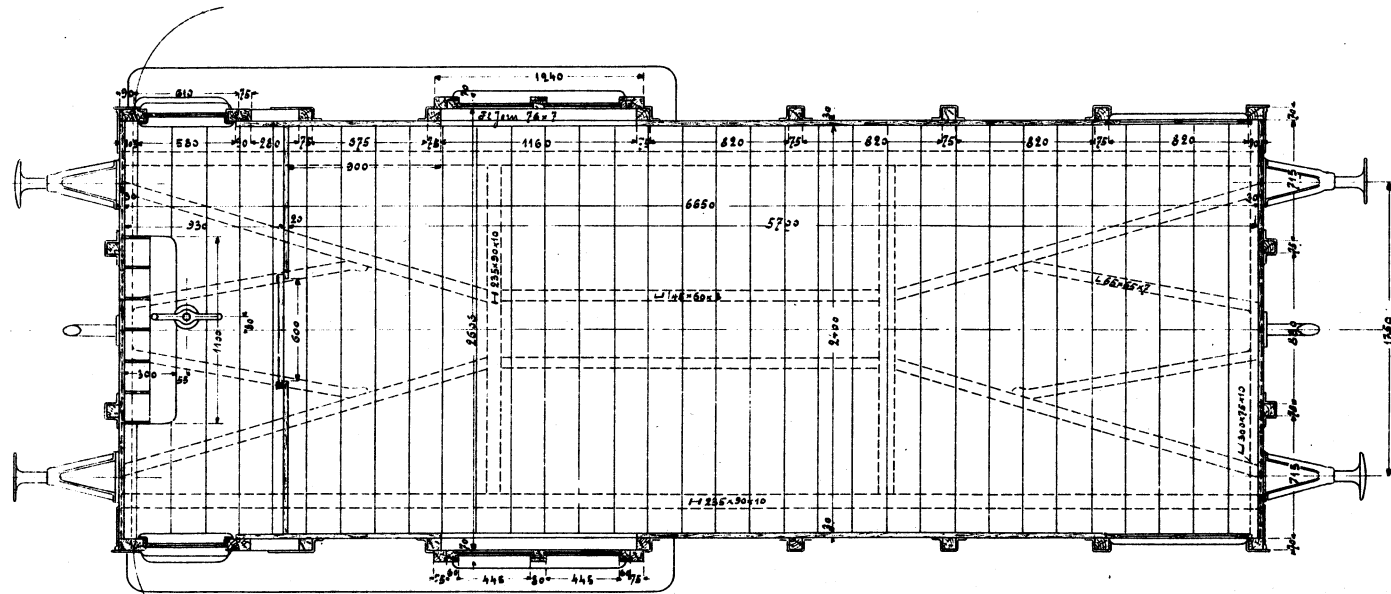
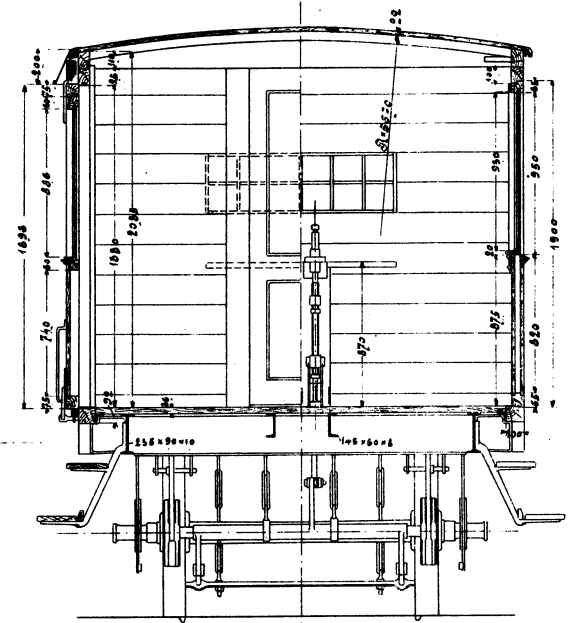
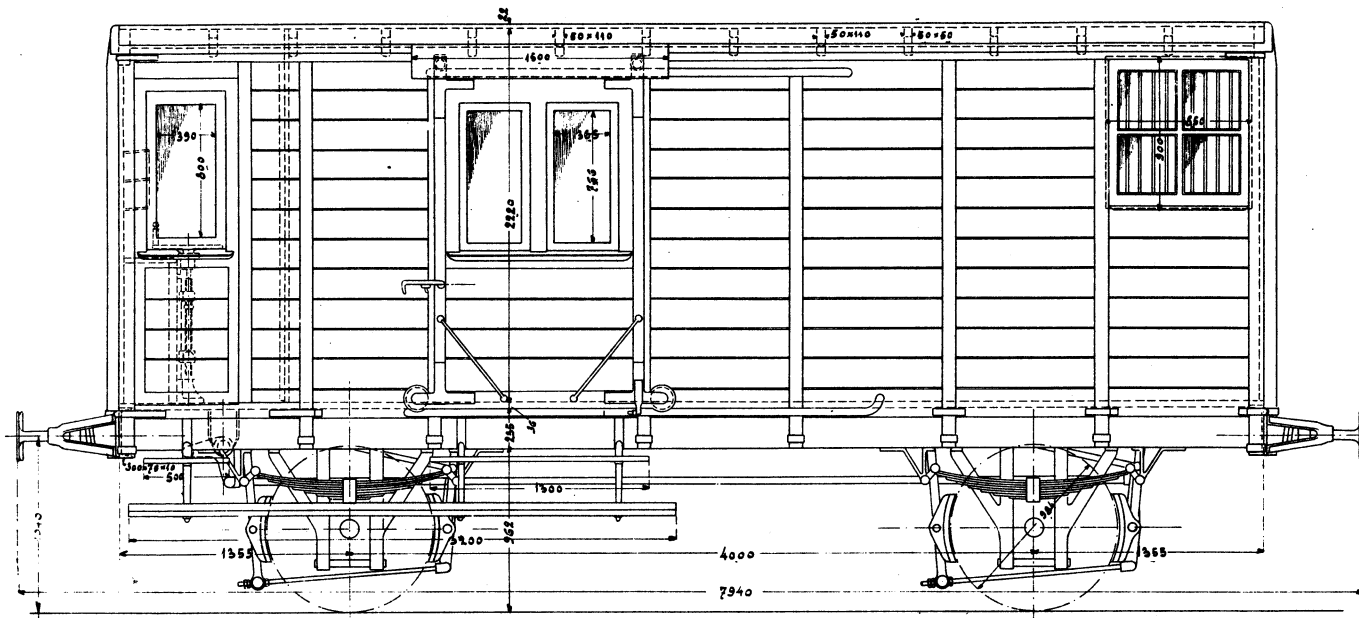

1008

TFJ Qs 1-2 1904 VULCAN

Nr. 7935.

Scandia i Randers.

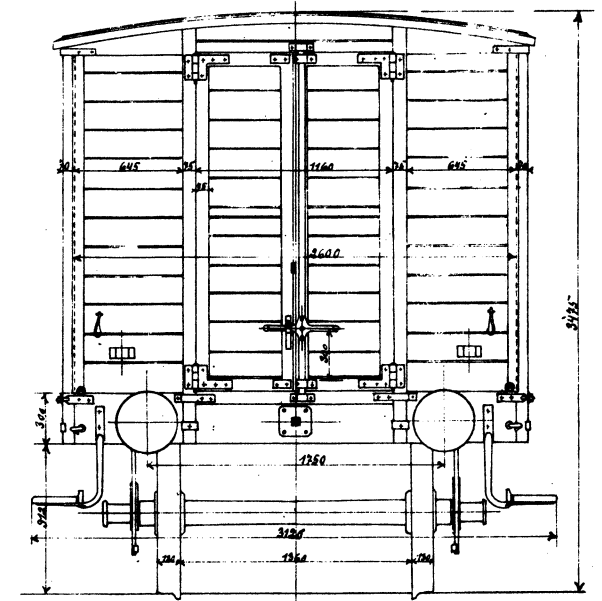
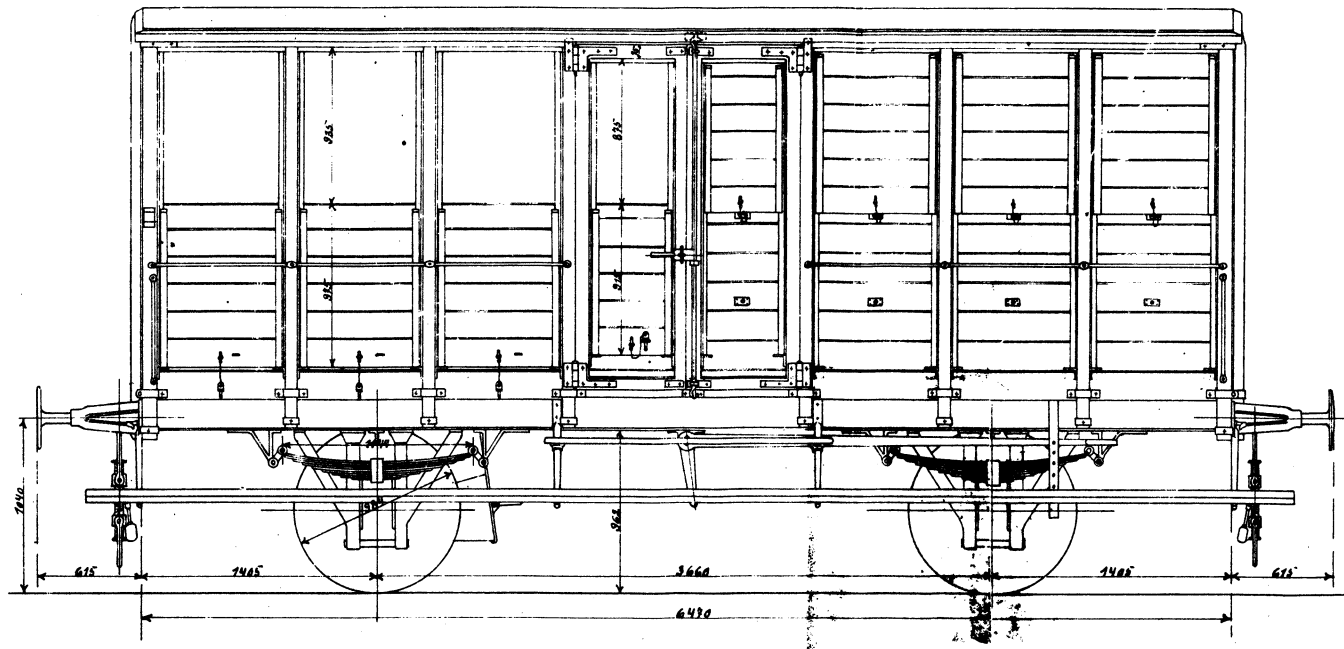

Løkke Gods og Bankvegen

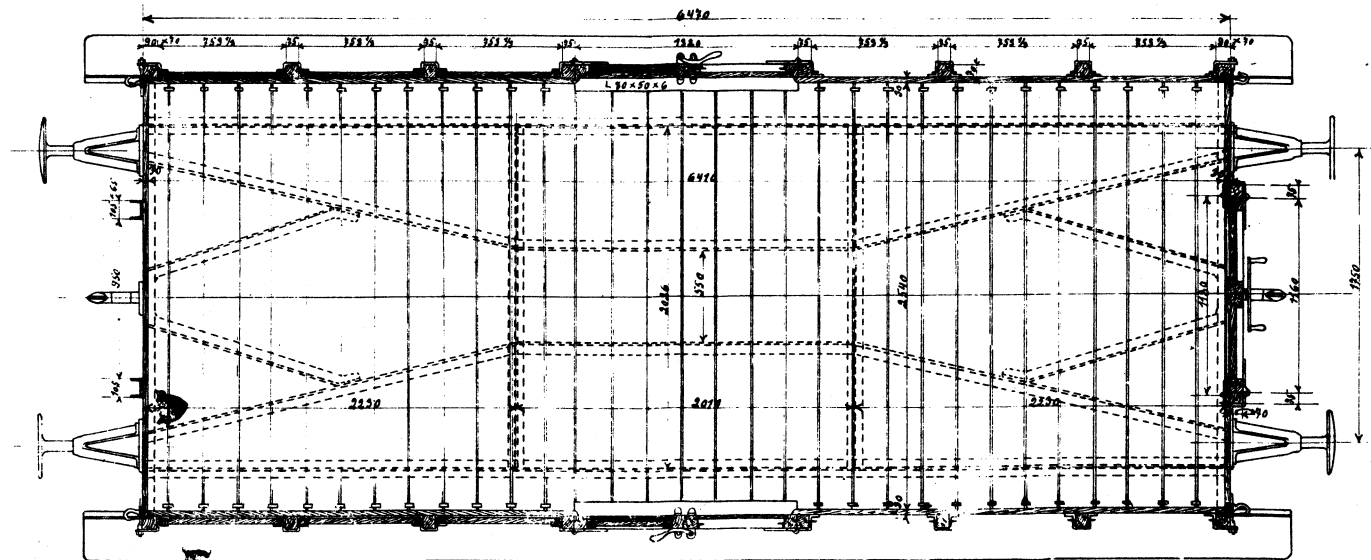

Scandia 2 15/2 1906
Løkke

TFJ Q 11-14
SCANDIA 1906

Scandia i Randers.

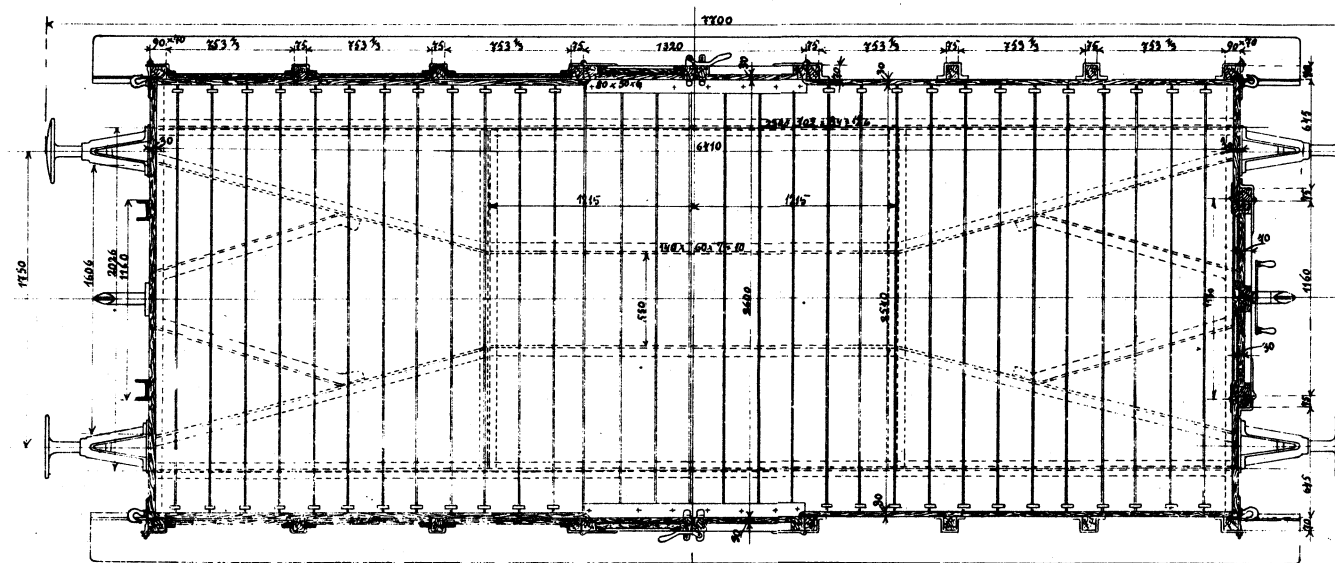
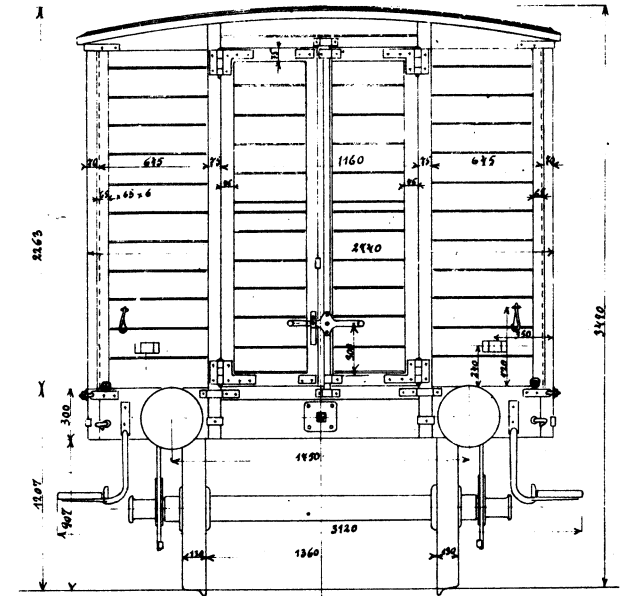
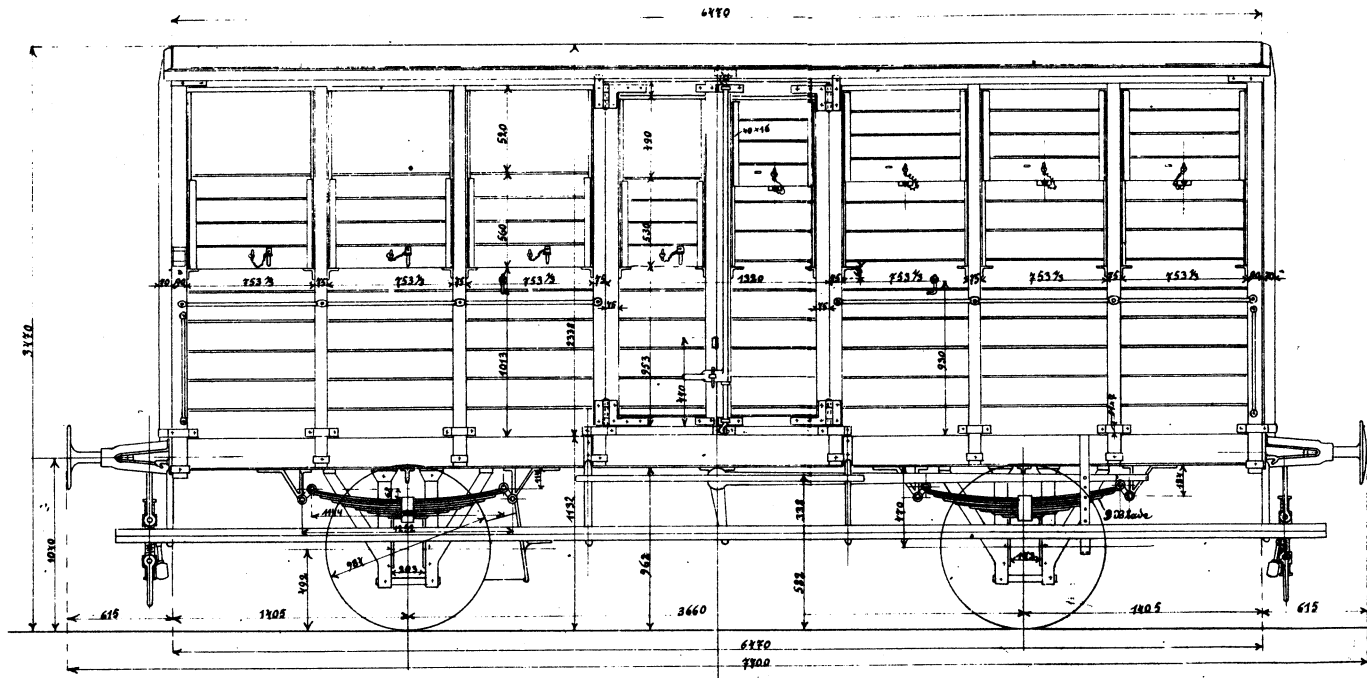

Luffet Godsvogn
til
Fisted Fjerntelefon Banen.
Vægt = 6880 Kg.

Scandia 2/15/1906
Broholm

Konst. 10.

TFJ Q 15-22
SCANDIA 1906

Aaben Godsvegn.

Com 1223.

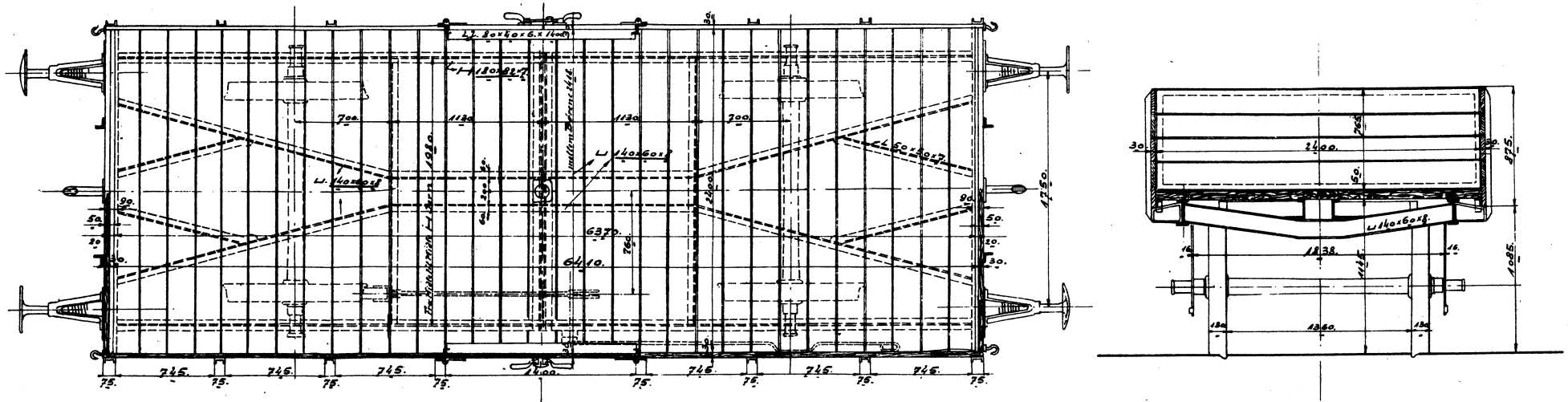
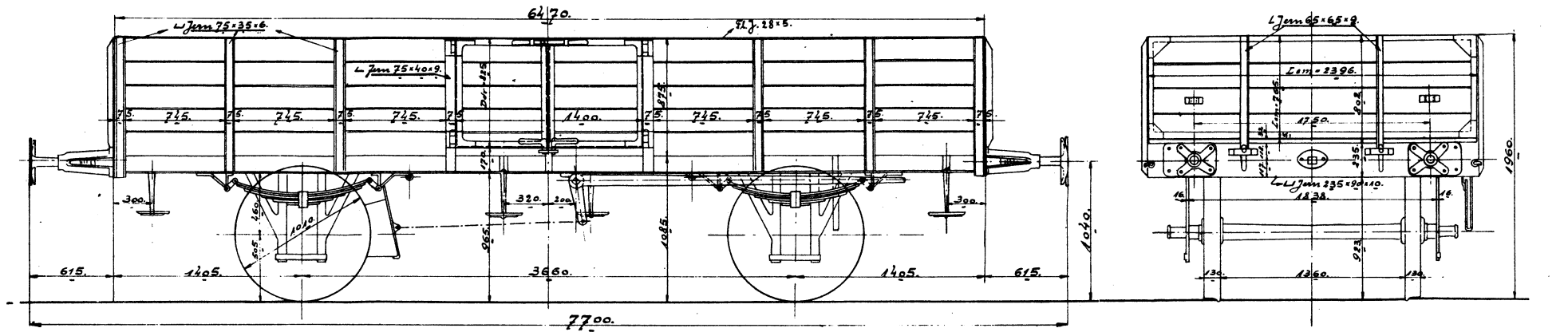

1075.

TFJ P 1-5 VULCAN 1904

Aaben lavsidet Godsvogn.

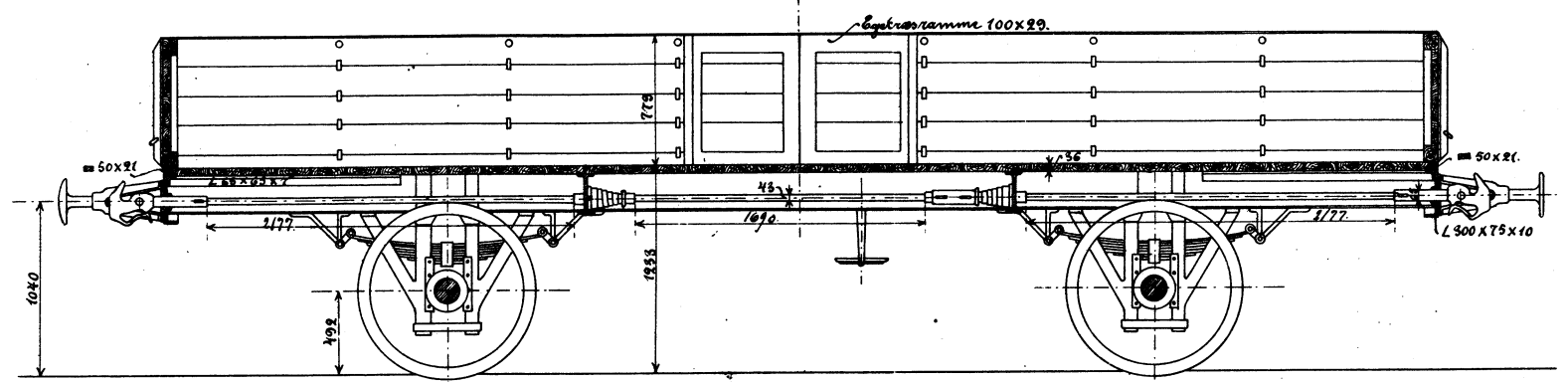
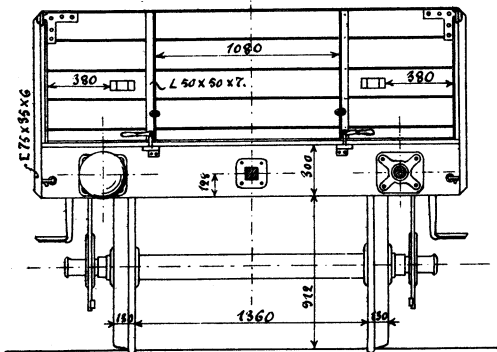
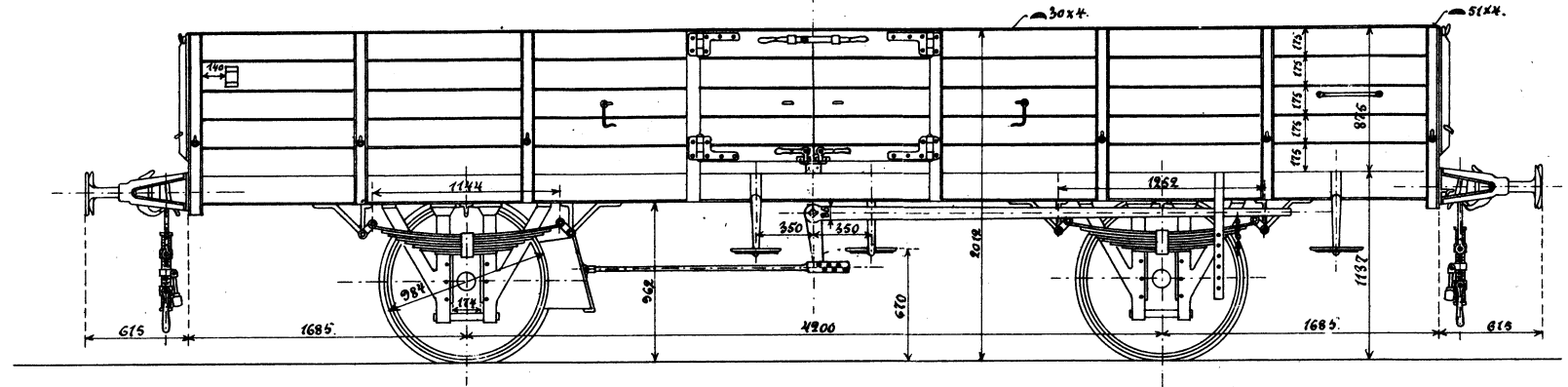
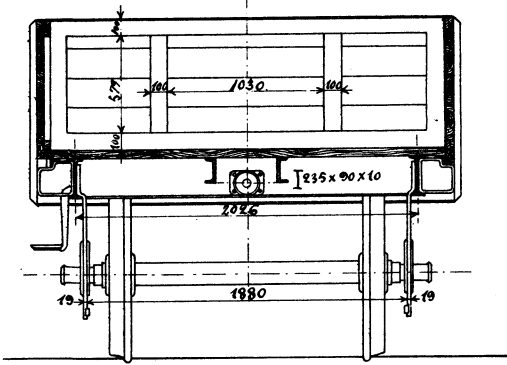

Type B. $F_{pr} = 36,5 \text{ t}$
 $G_p = 3,82 \text{ m}$

TFJ PL 11 - 15
 VULCAN 1904

749.

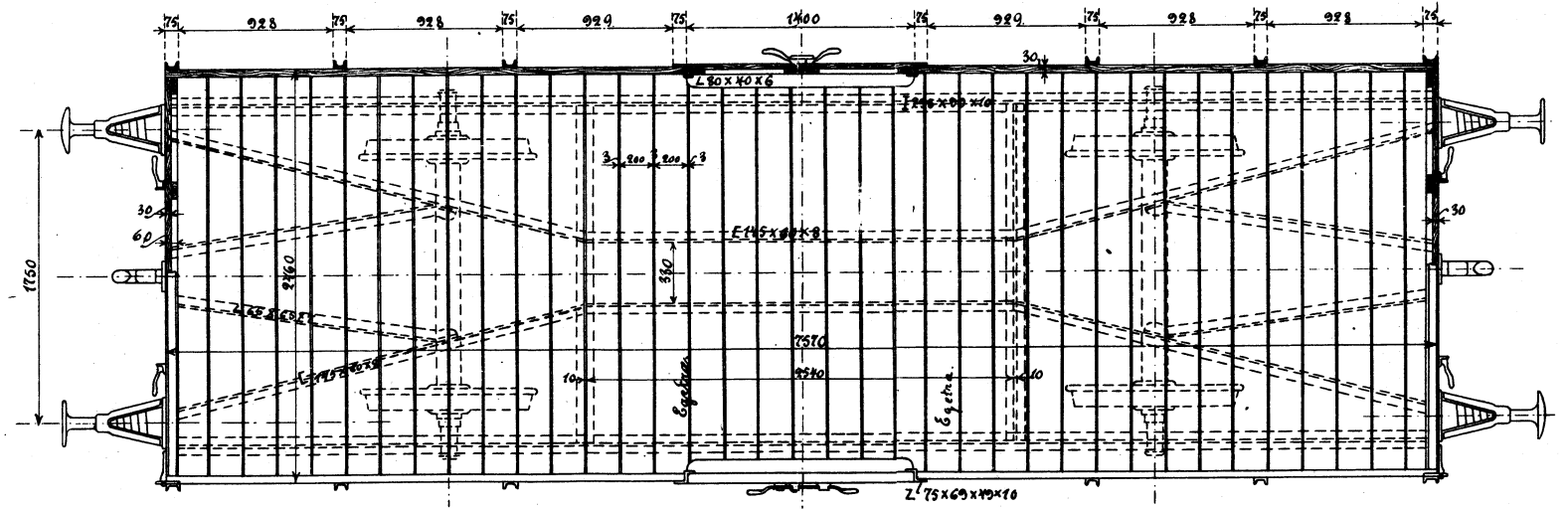

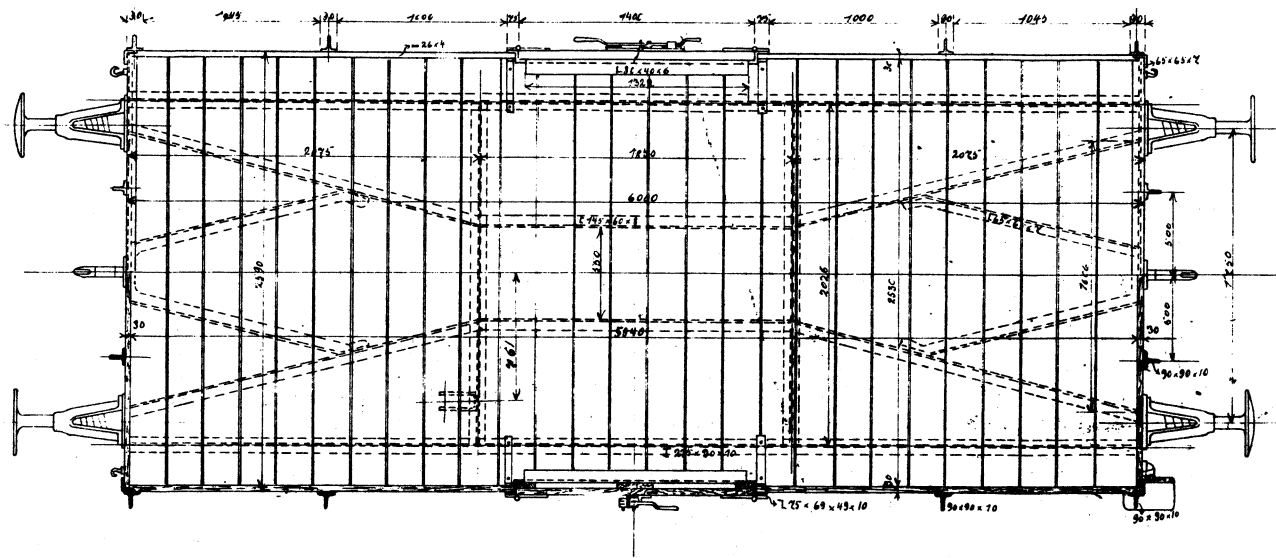
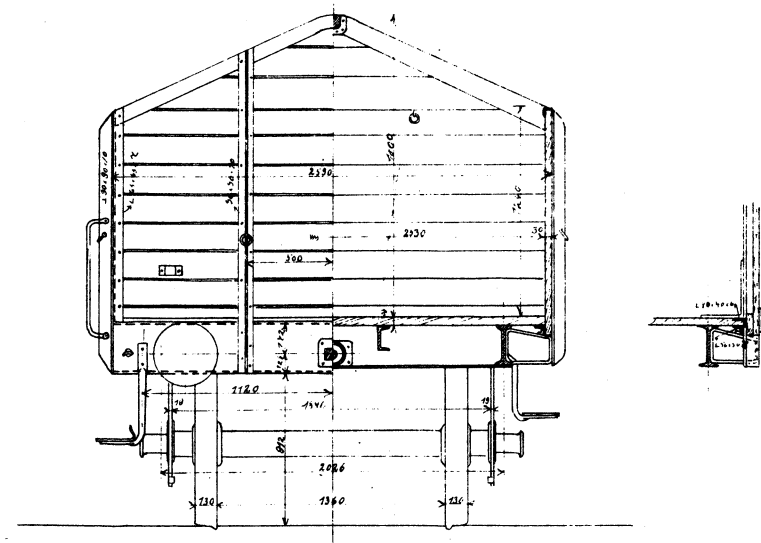
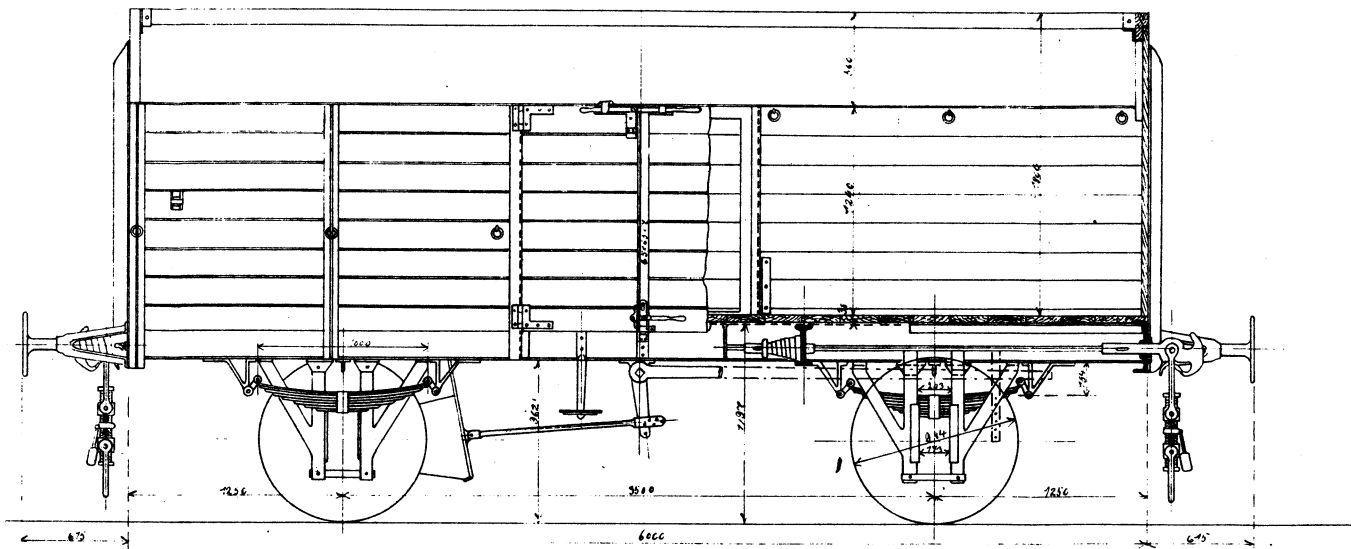

*Slaben höjsidet Godsvagn
 til
 Thisted-Fjerzitslev-Jernbane.*

**TFJ K 1-4
 SCANDIA 1906**

*Scandia 25 1906
 Beckmann*

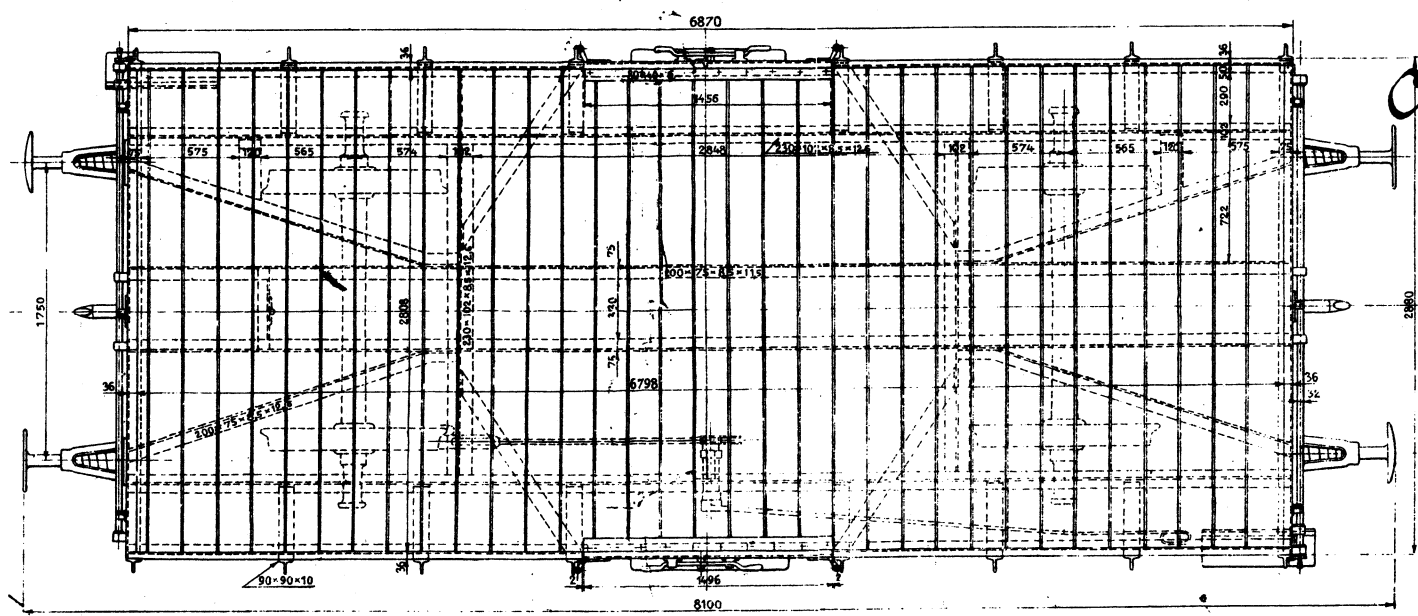
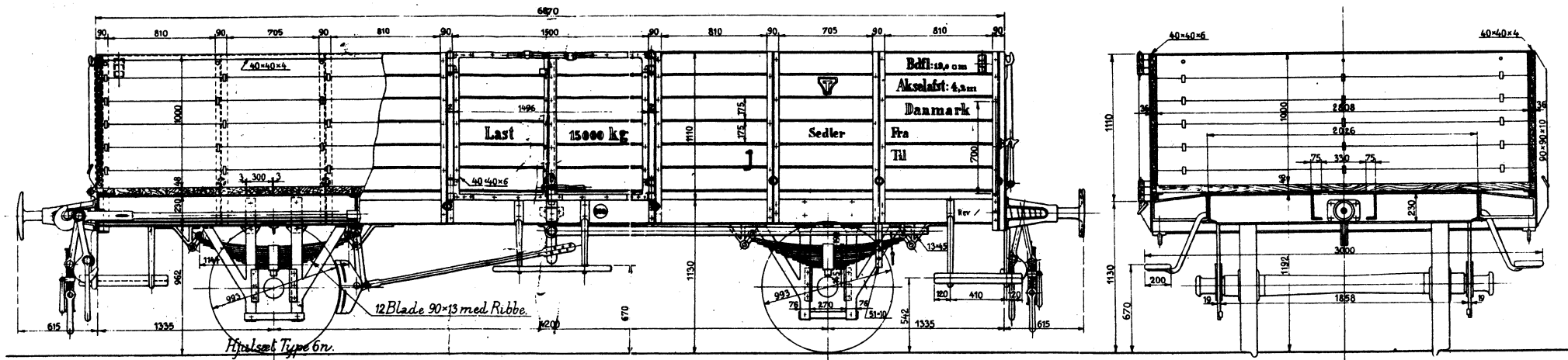

Platen lavsided
Godsvogn
Litra Sj.

TFJ P, 15 - 16
 SCANDIA 1942

№. 7726.

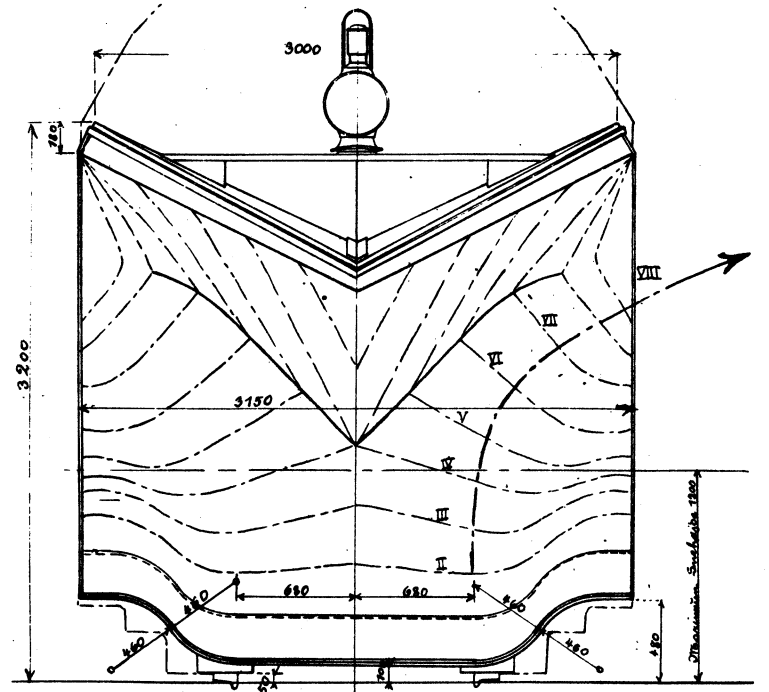
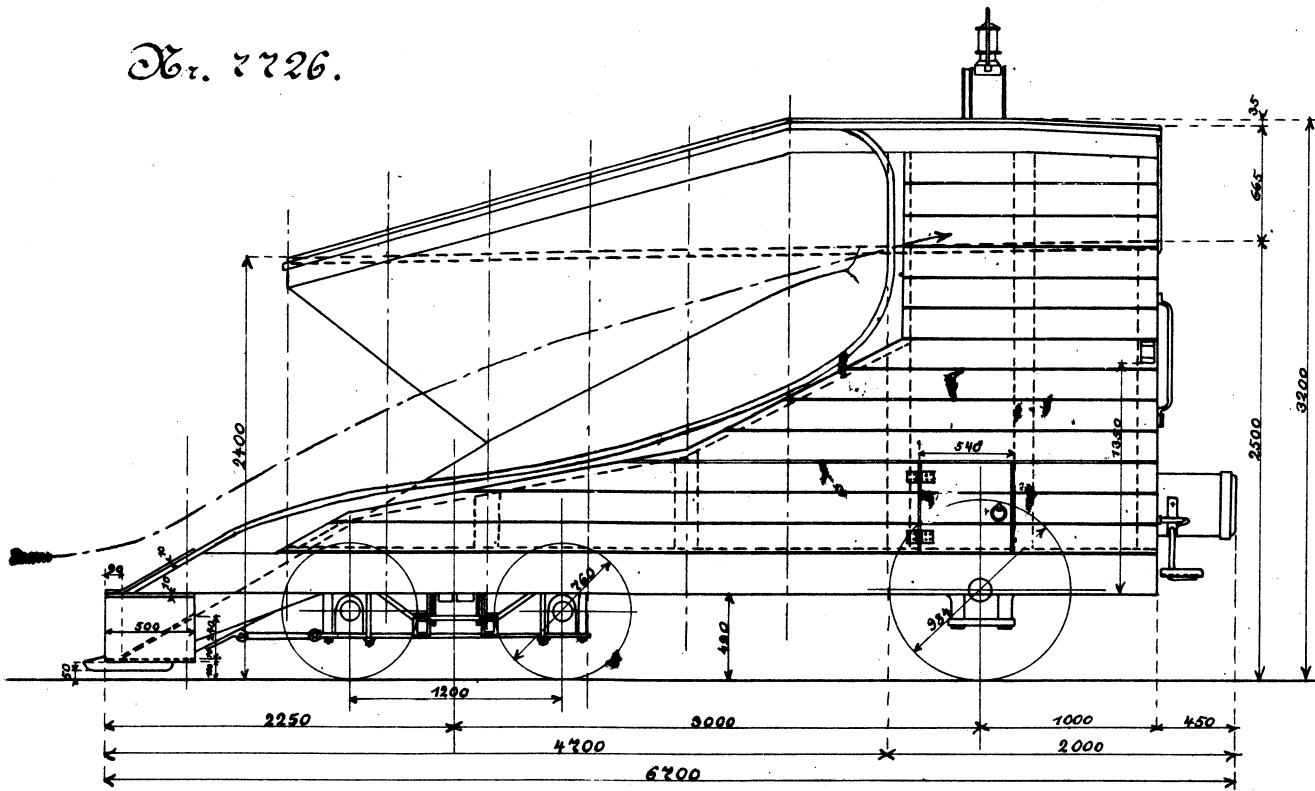

вн Снеплов весом 8440 кг.

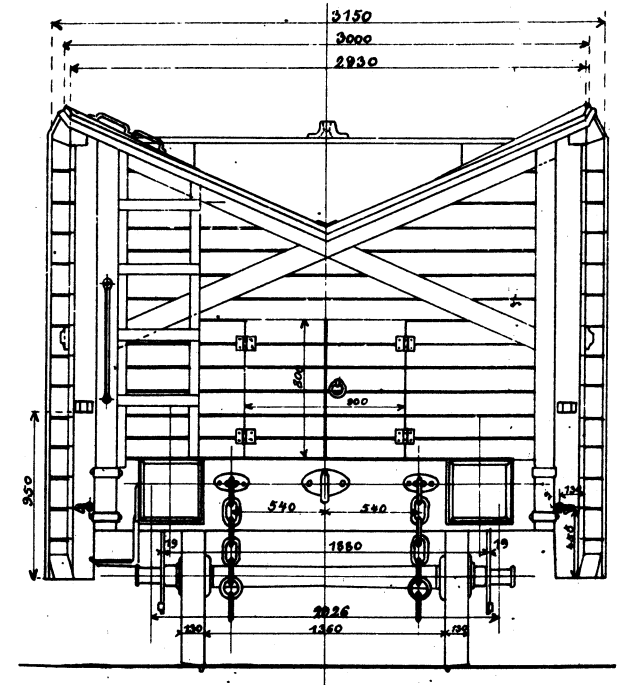
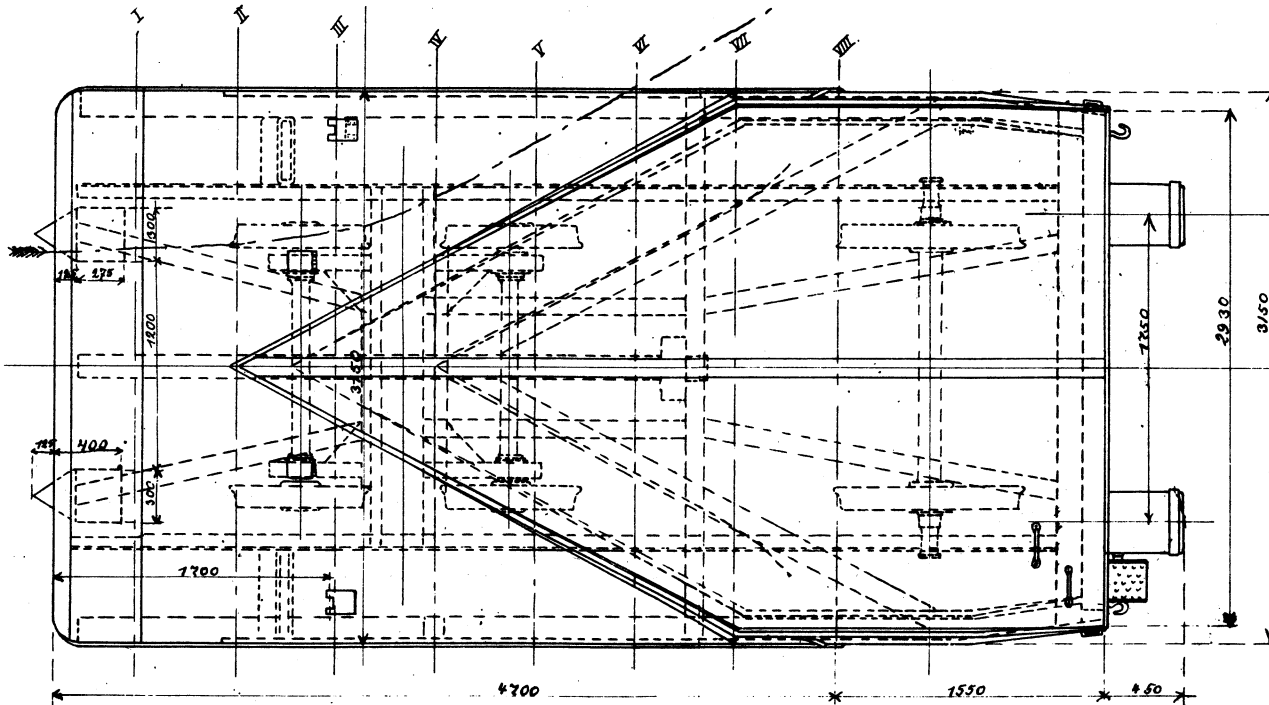

TFJ sneplov nr1 SCANDIA 1904

Facade.

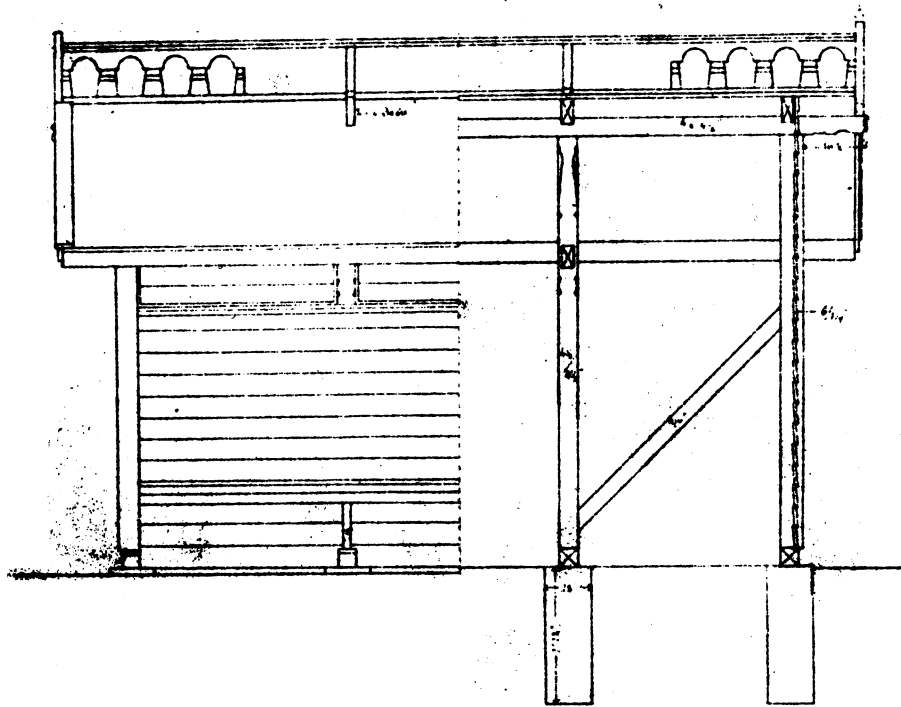

Længdesnit.

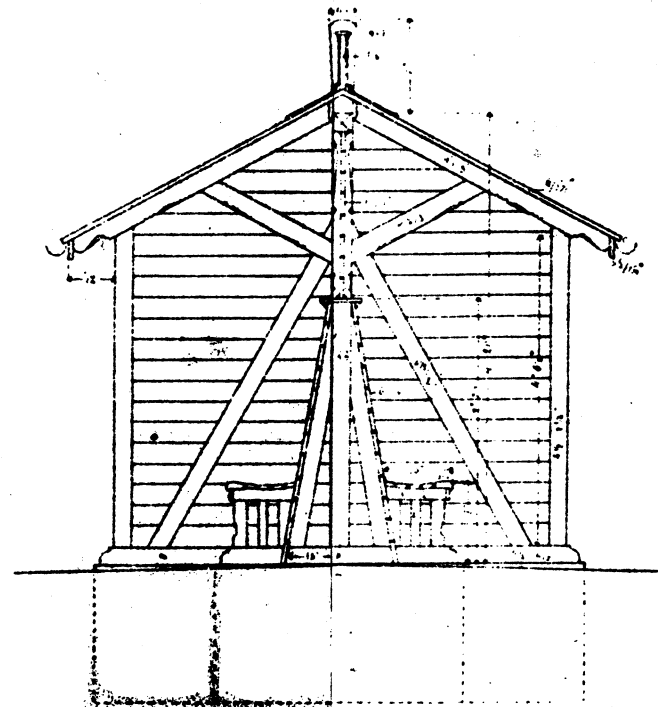

Endesnit.

Savl.

Plan.

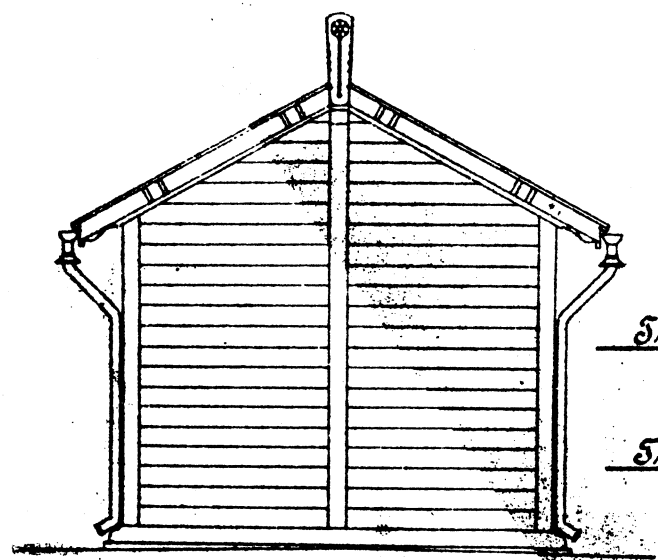
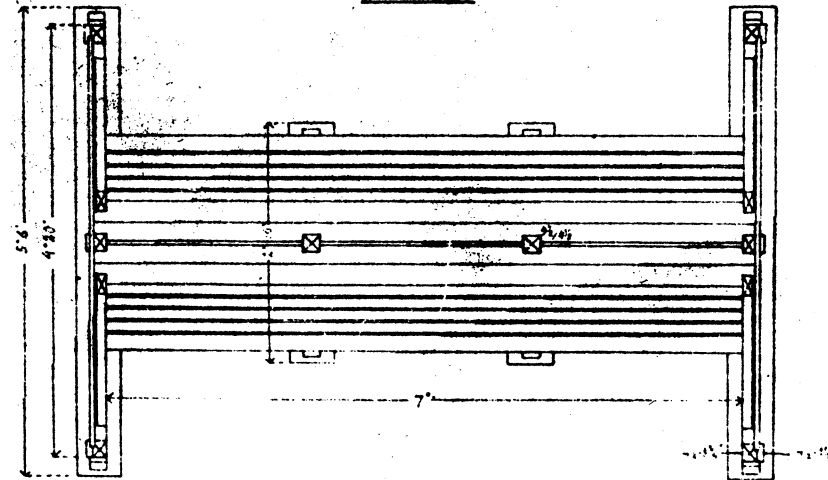

Erabrygning
ved
Svinbræder.

Tristed-Ferritslev-Baner.
Vogterhus.

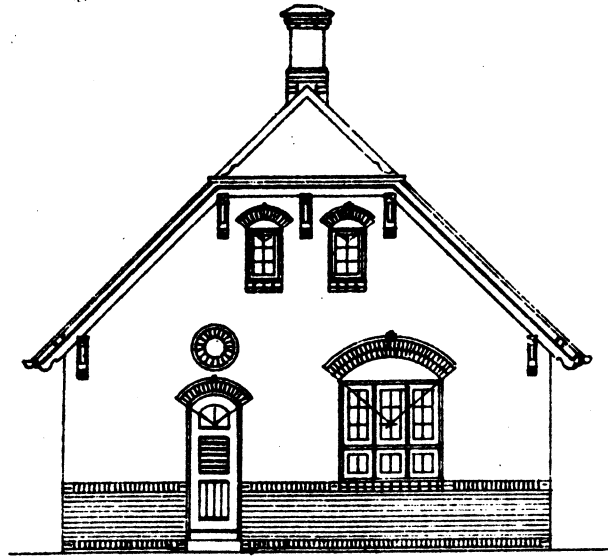

Med Porten.

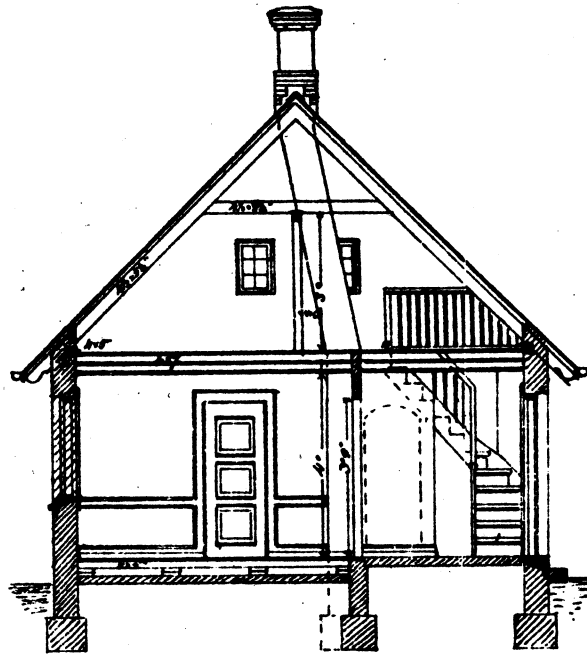
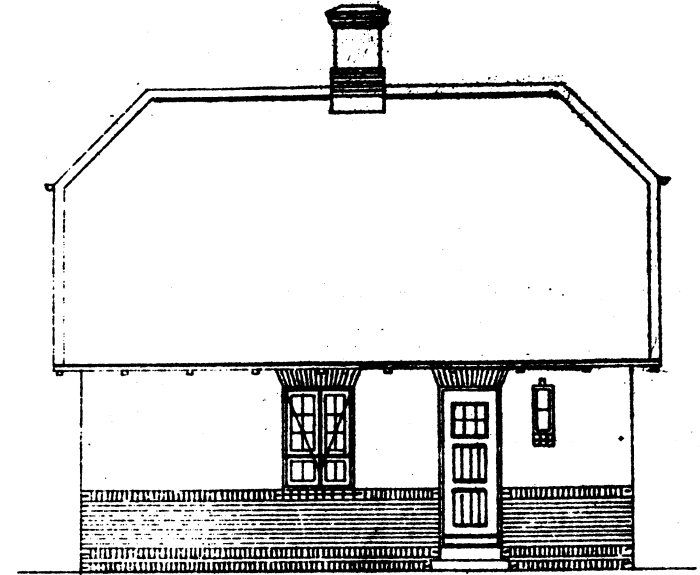

Fig. 1-2.

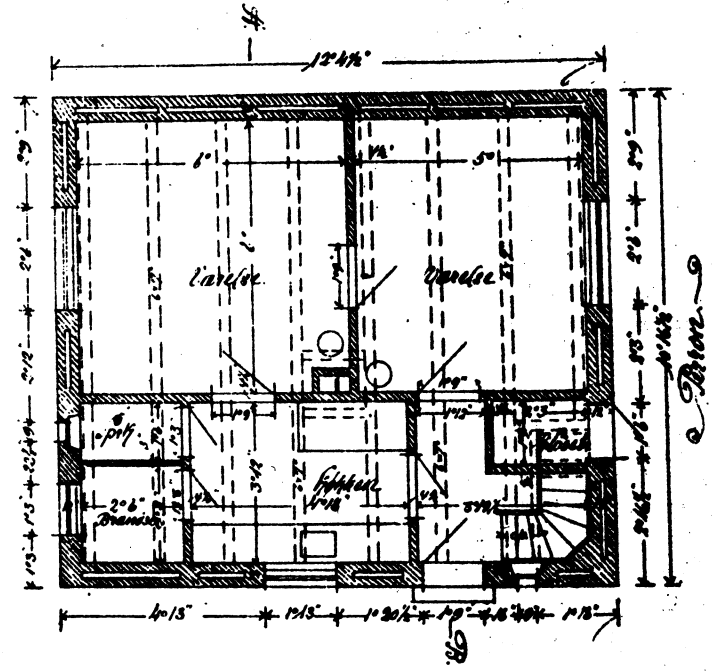
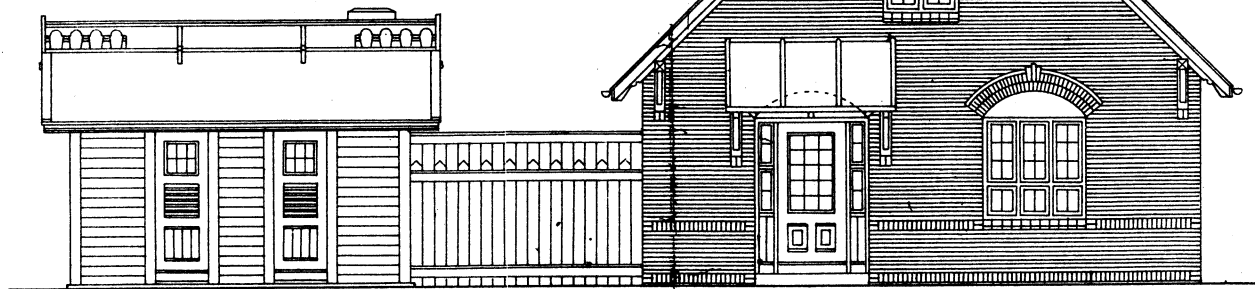
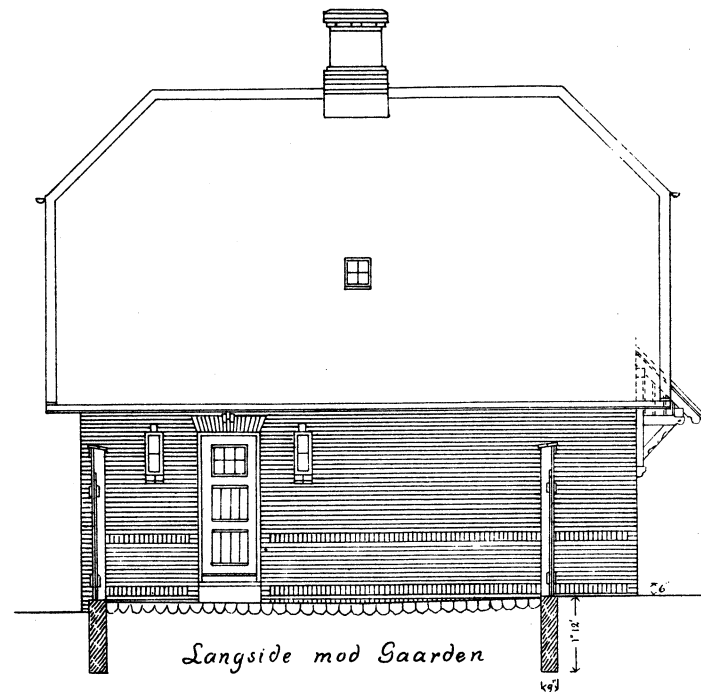

Fig. 3

Thisted-Fjerritslev Jernbane
Banevogterhus med Billetsalg
Sjøttrup



Facade mod Perronen



Langside mod Gaarden

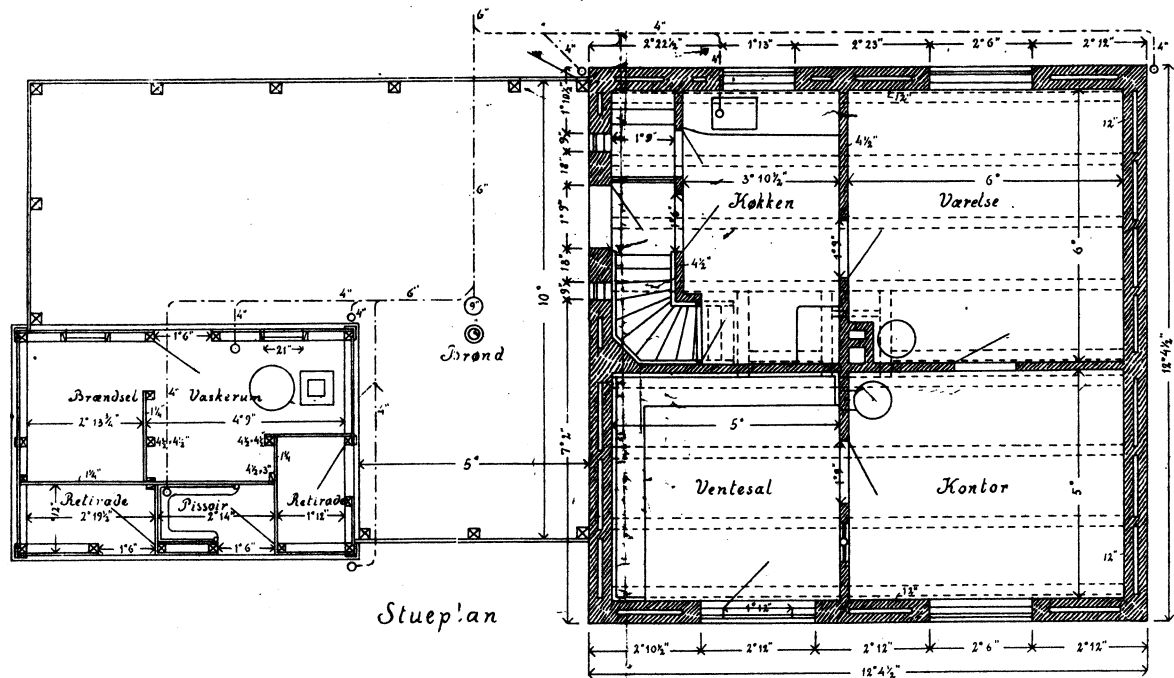

Stueplan

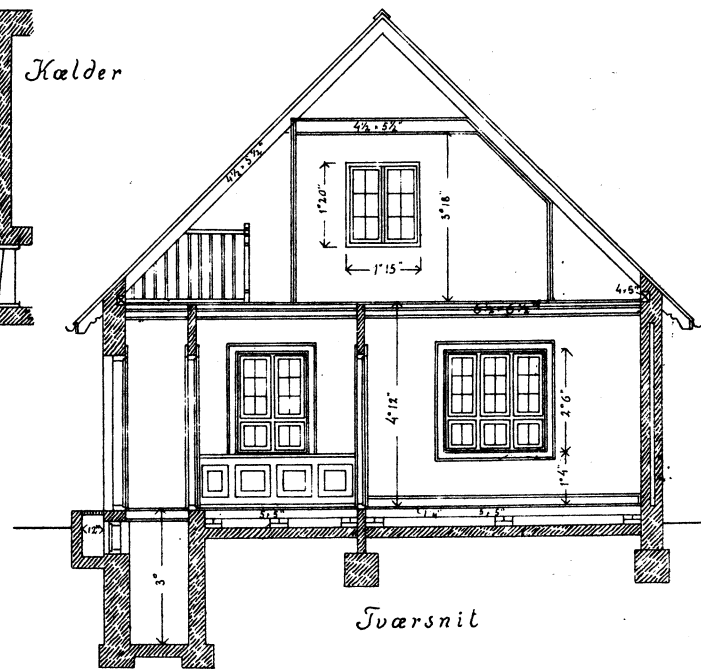
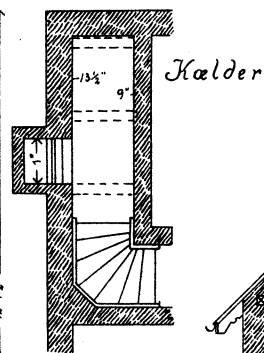

Tværsnit

1:100

*Thisted Herreds-Paaren
Vest af Tommerby.*

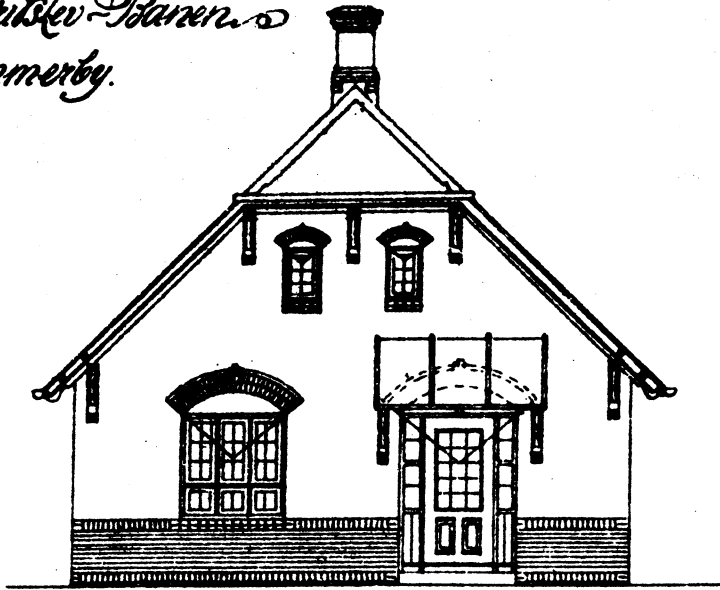

Mod. Person.

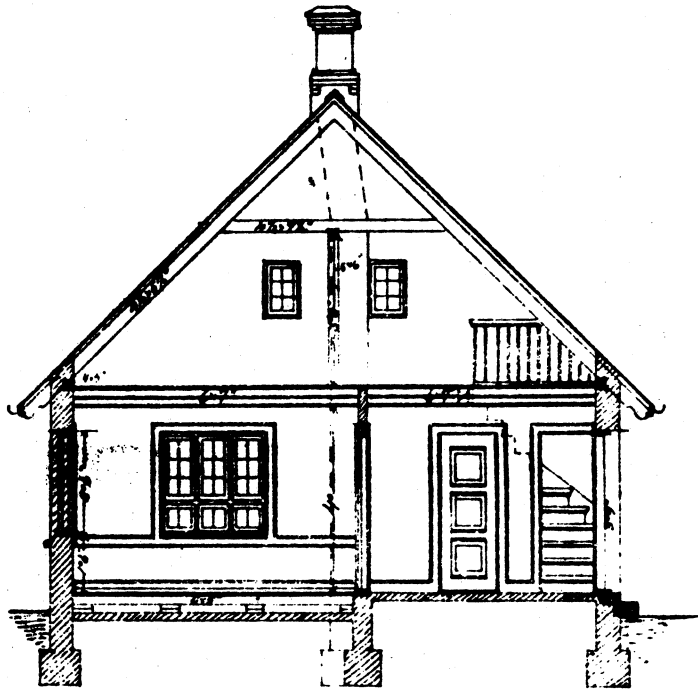
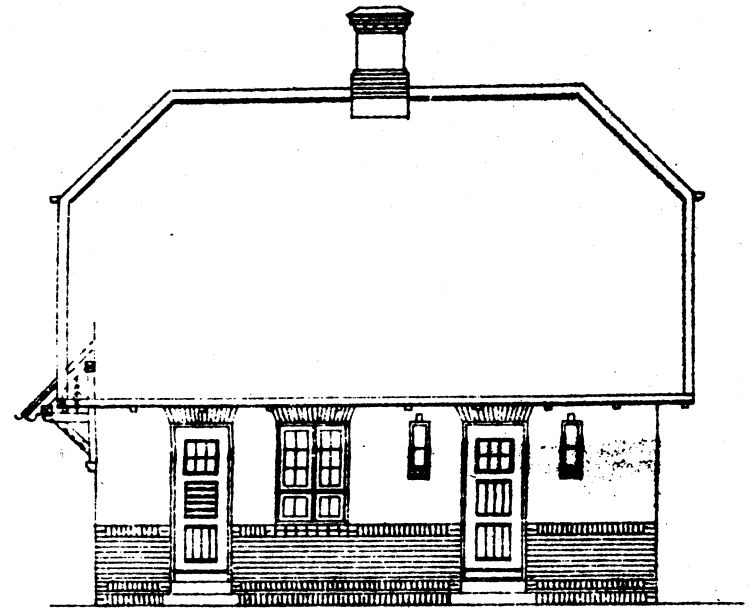

Mod. H-B.

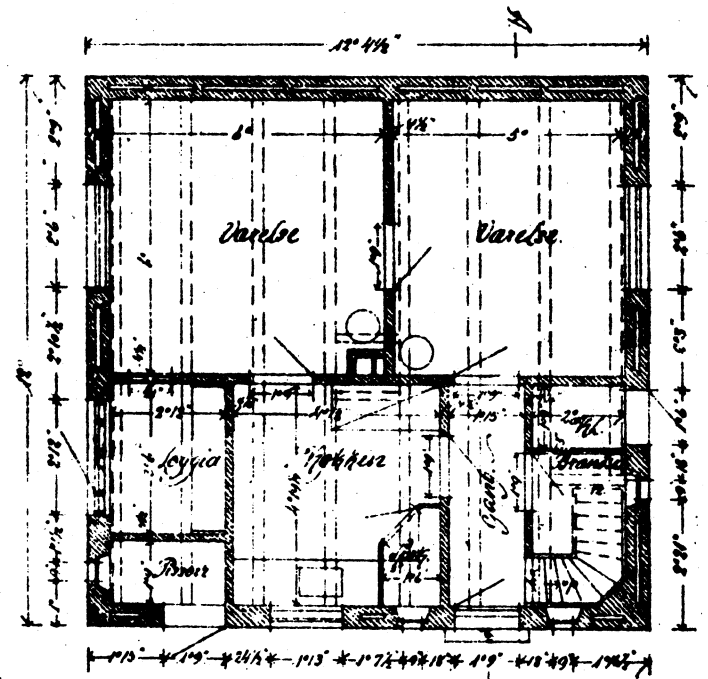

Person

Plan

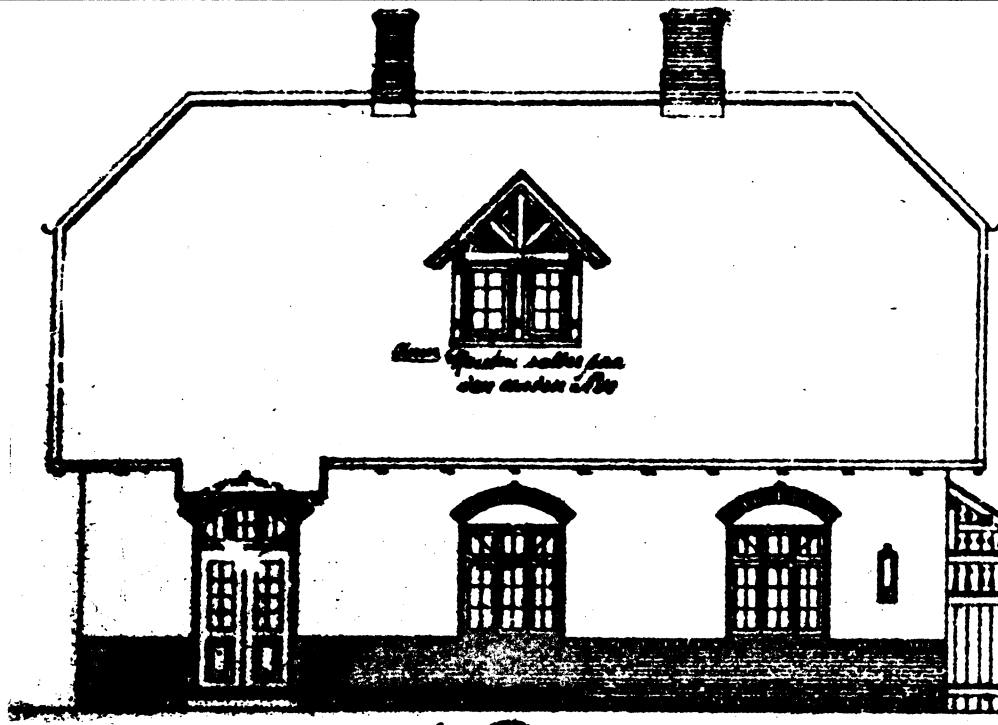

Tristed - Fottitslev. Parner. s.

*Osterid.
Aars.*

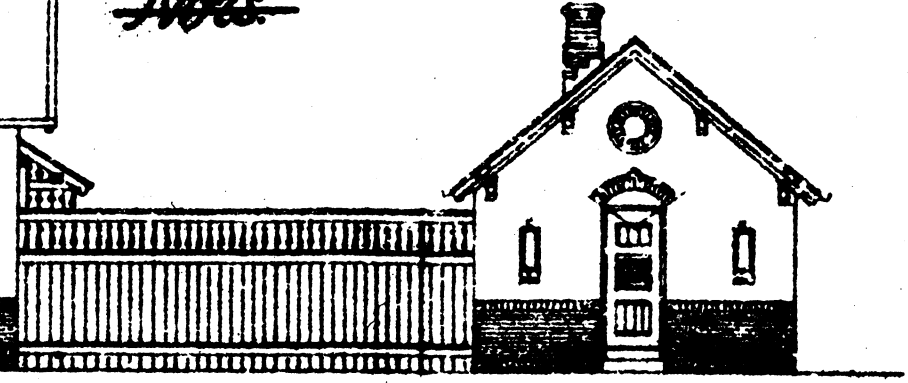

Als Parner.

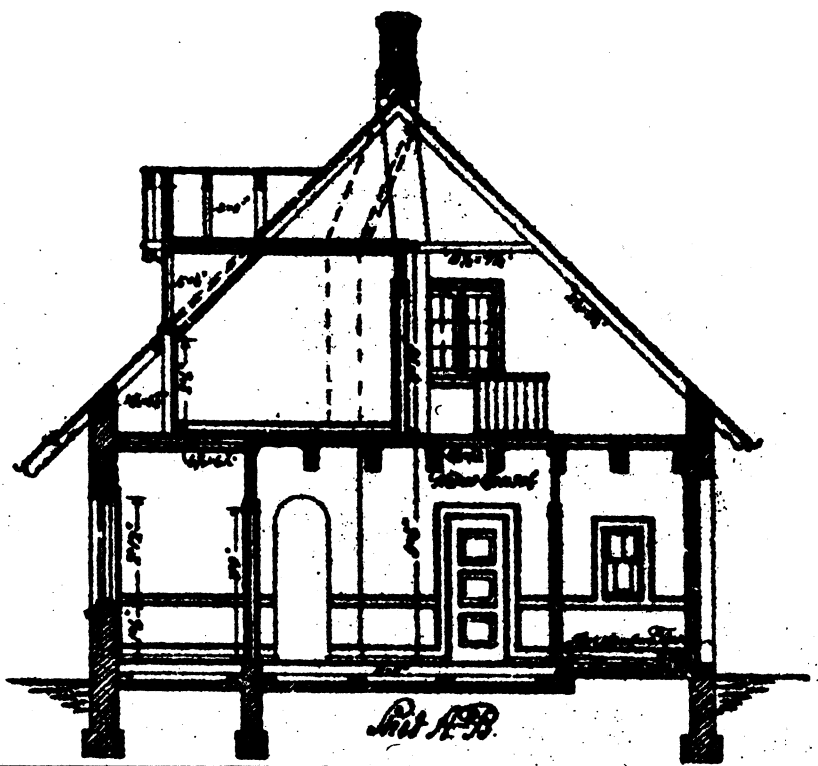

Als A.B.

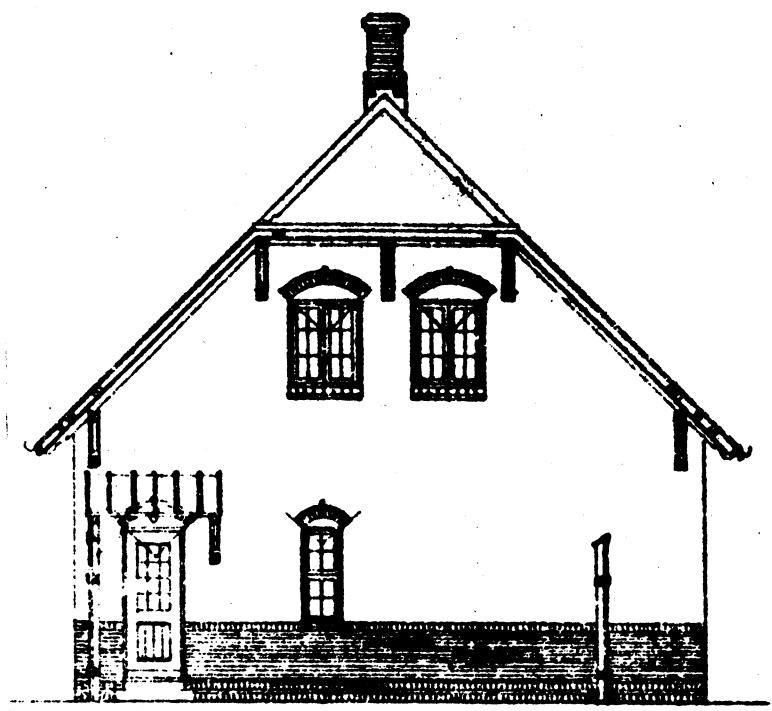

Tristed - Fortitico Panen. o.

Osterid.
Nors.

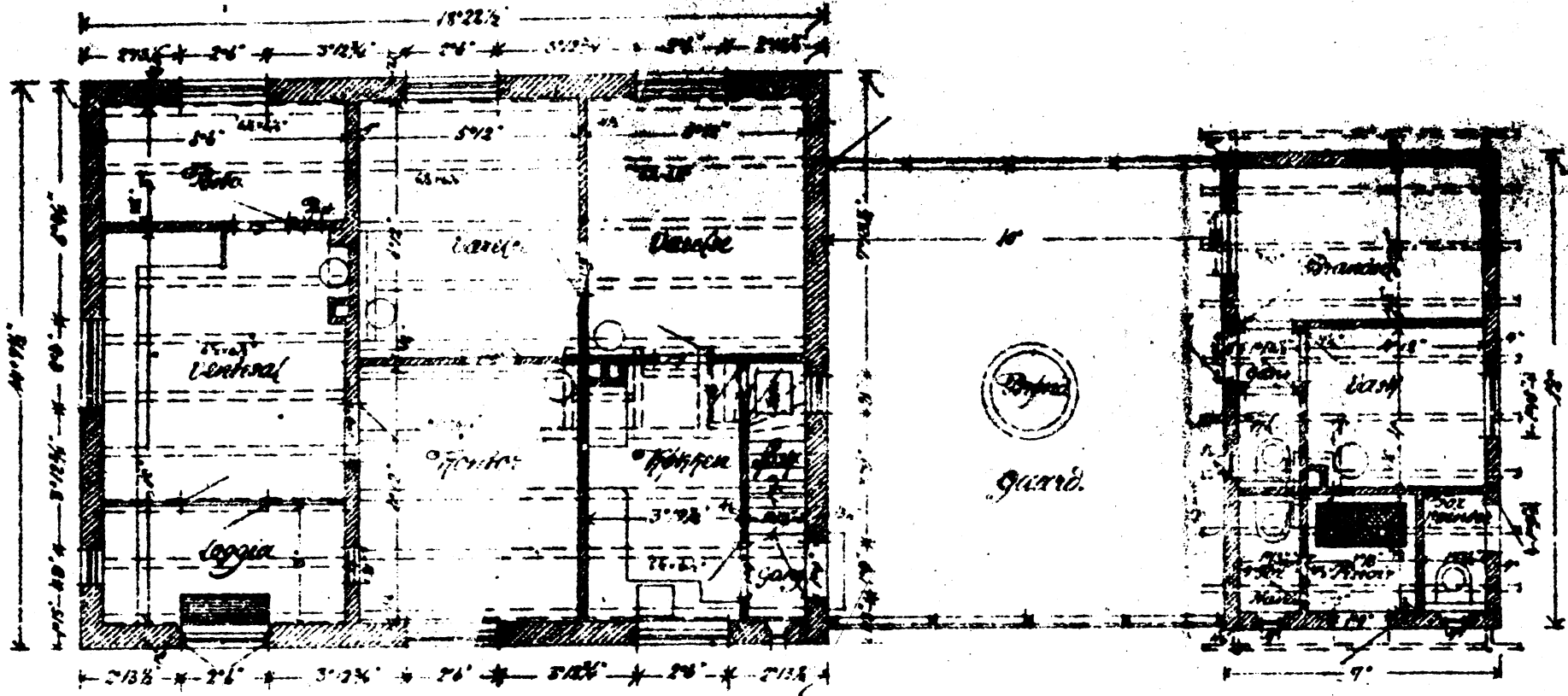
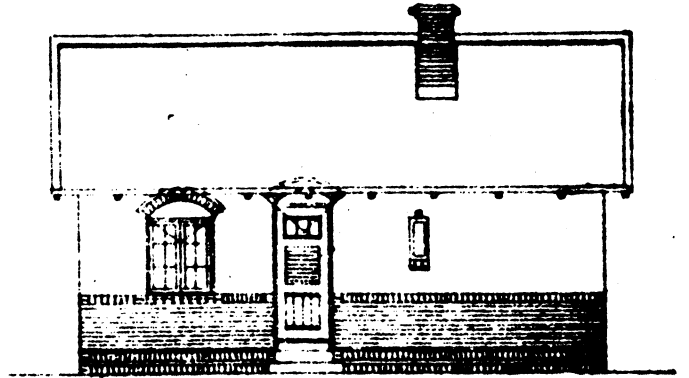

Dieplan

8/10

Peron

1:100

*Tristed-Fetritskov-Bauer
Fogstrup.*

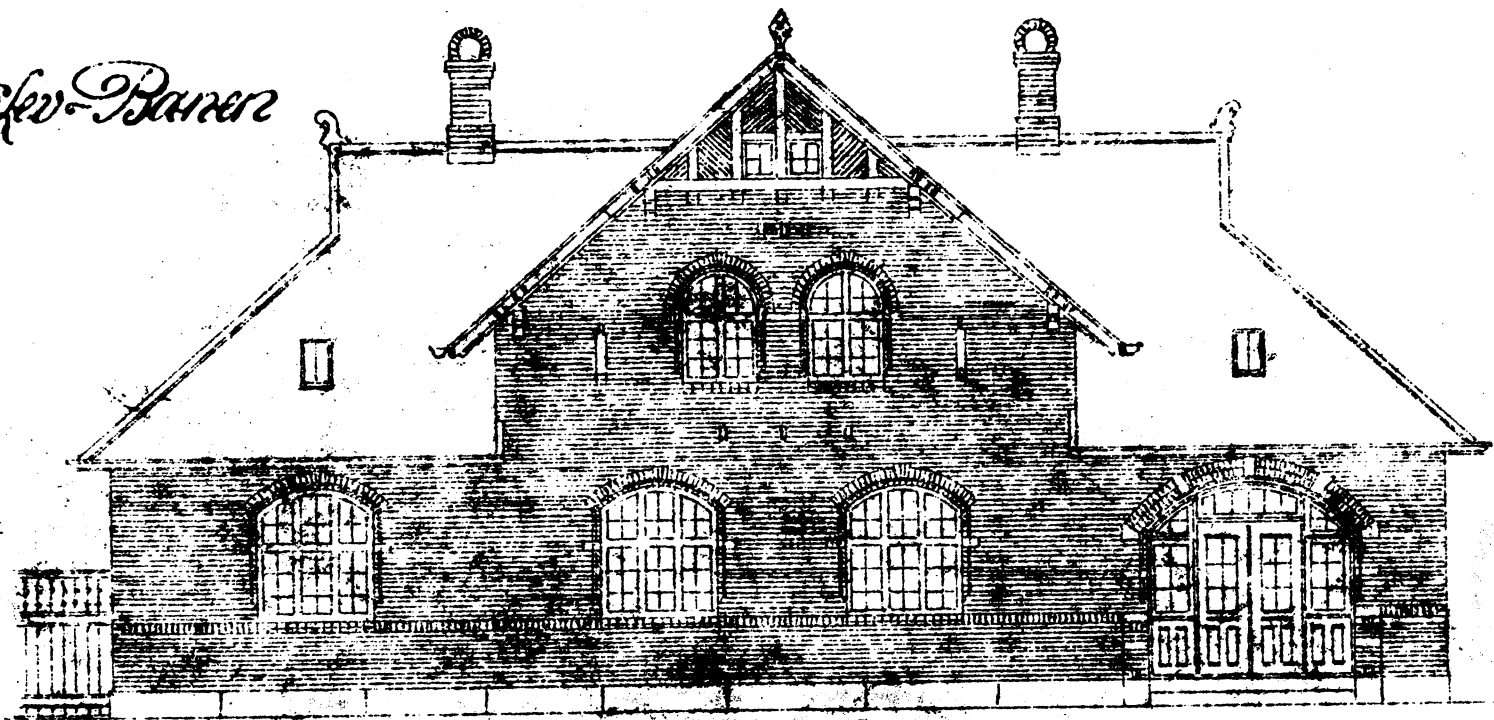

Facade mod Veg.

1:100

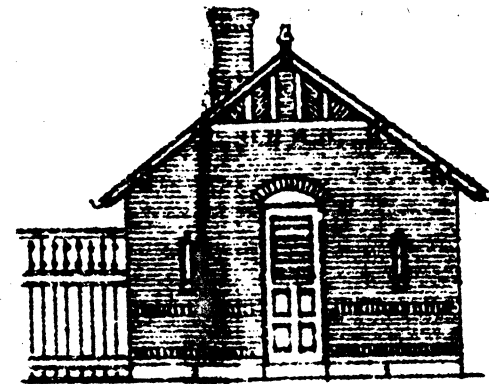
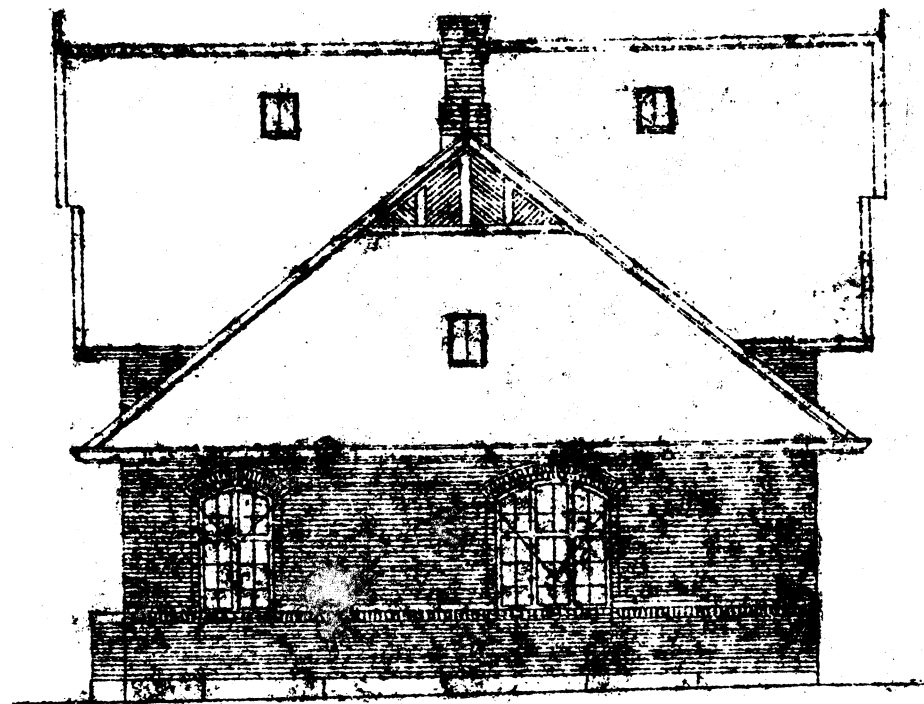

Tristed Fættelslev-Baner

Fæststrøg.

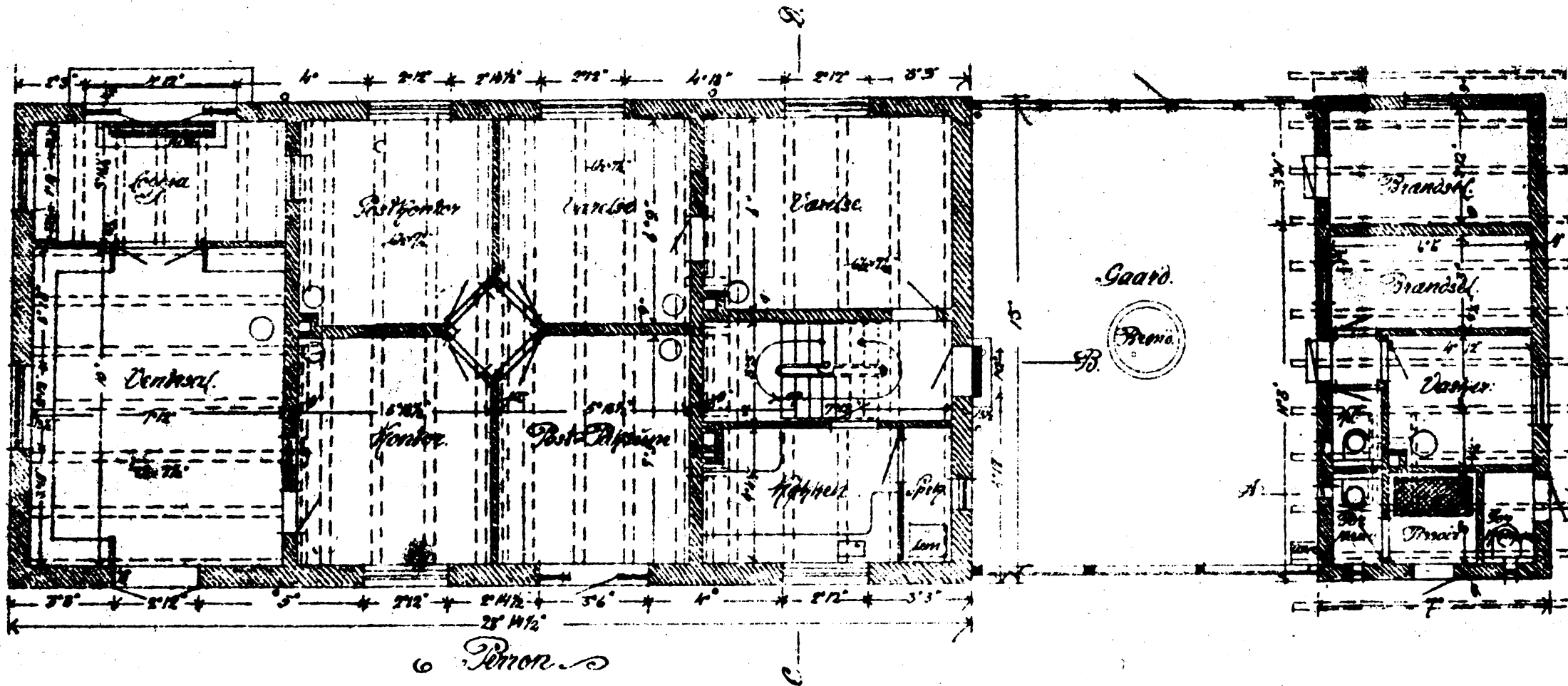

Tristed-Ferritslev-Banen.

Varehus-Type I.

Snit C-D.

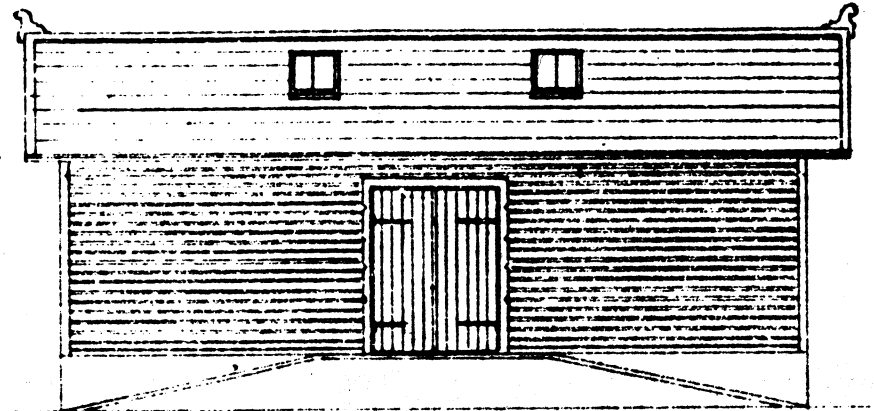
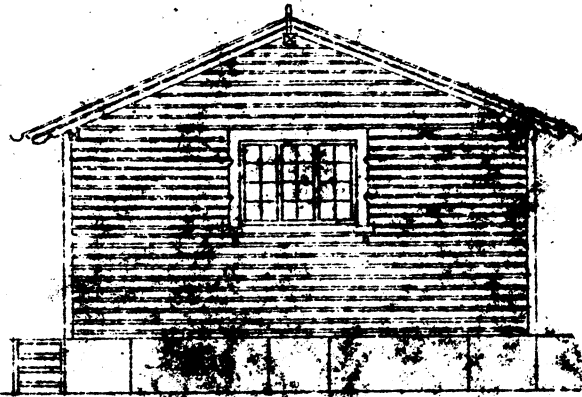
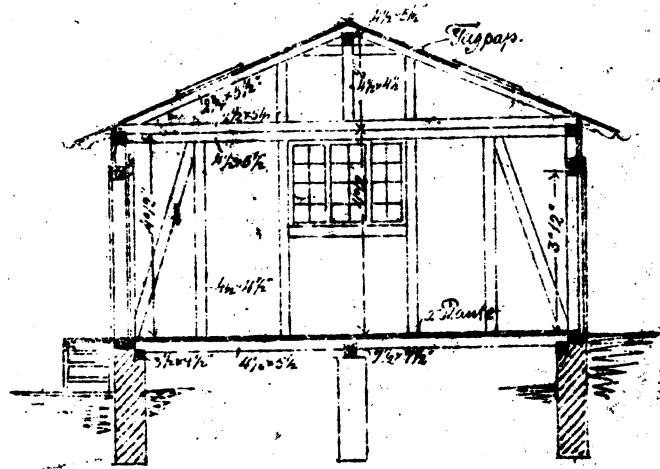

Nico Perron

Snit A-B.

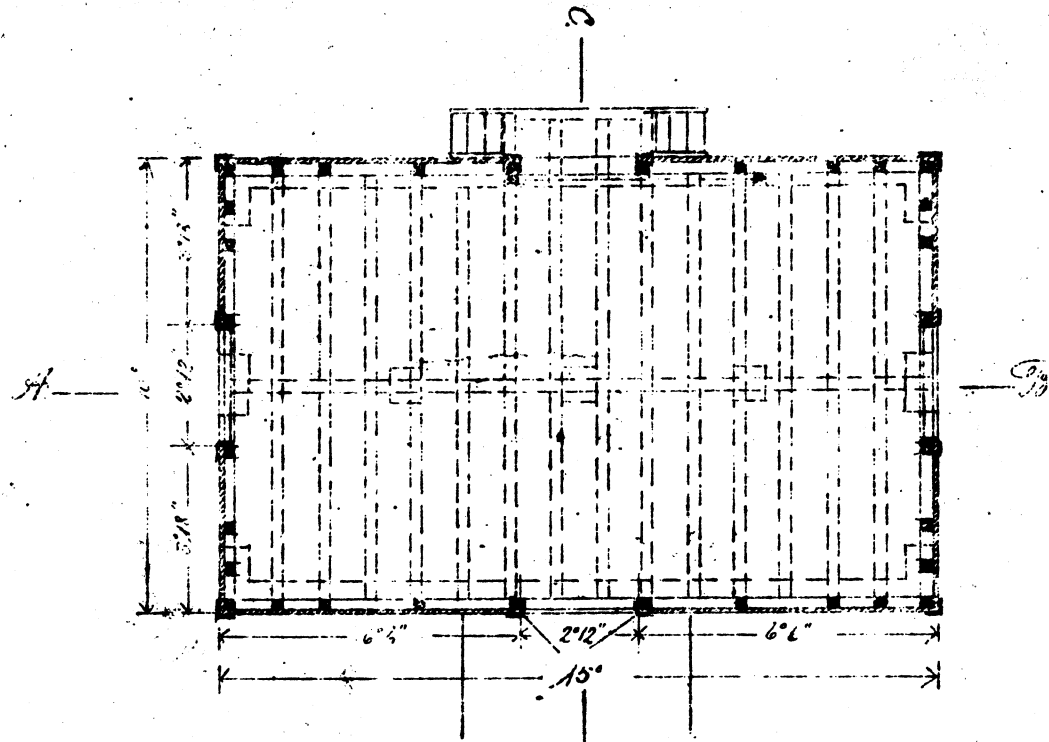
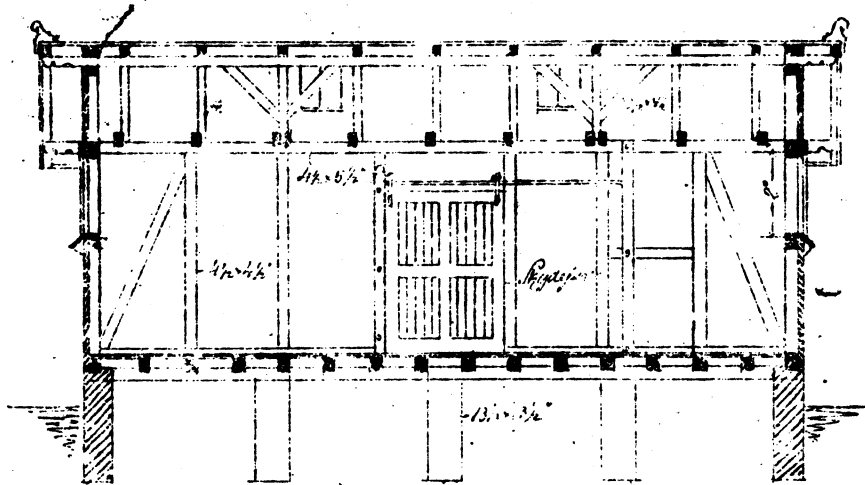

1:100

Perron

Trüsted Ferritsled Panere.

Varehus - Type II

Plat. C-D.

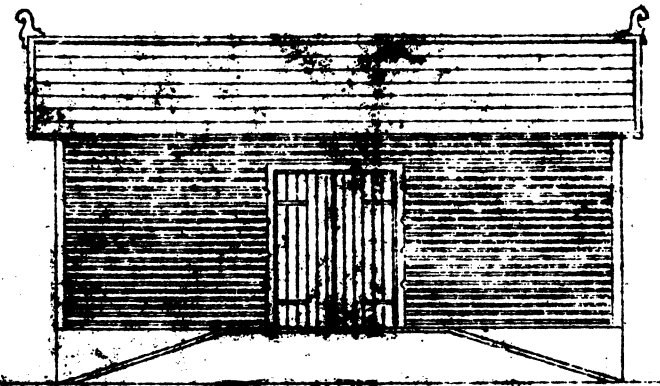
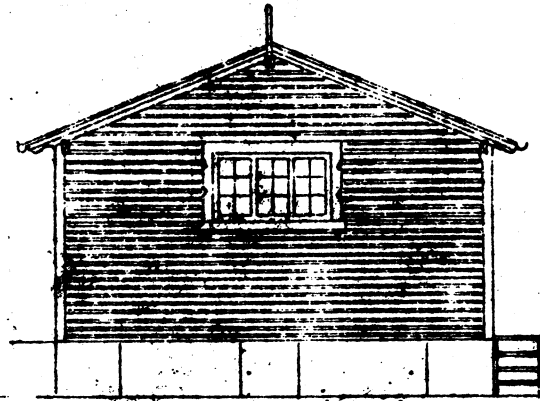
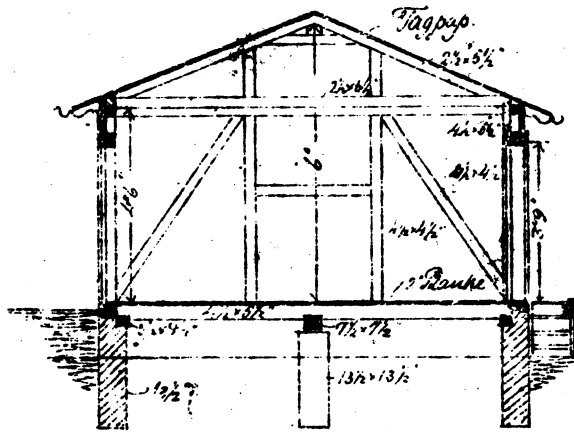

Med Ferron

Plat. A-B.

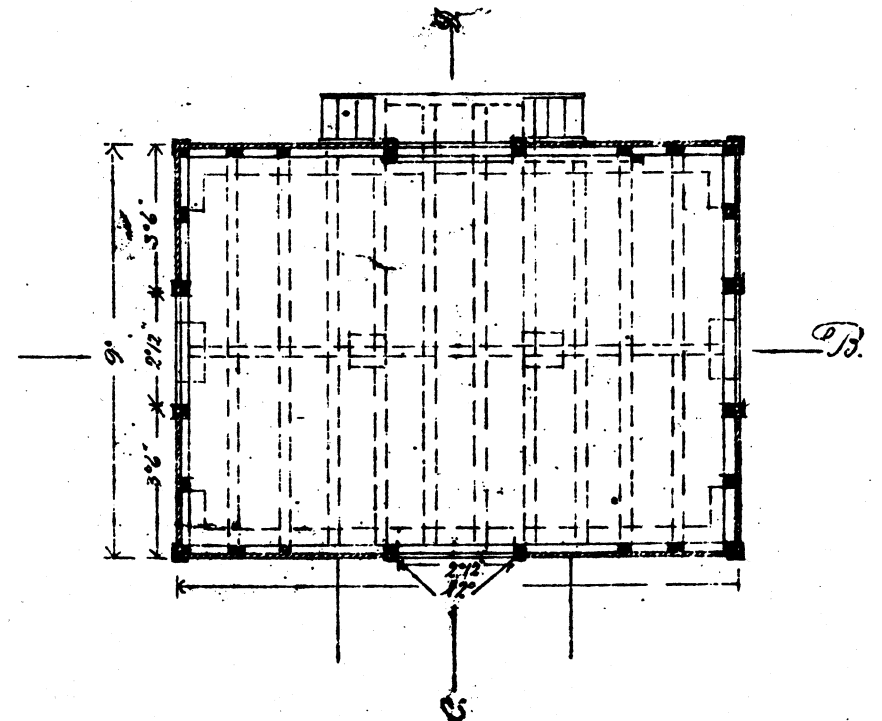
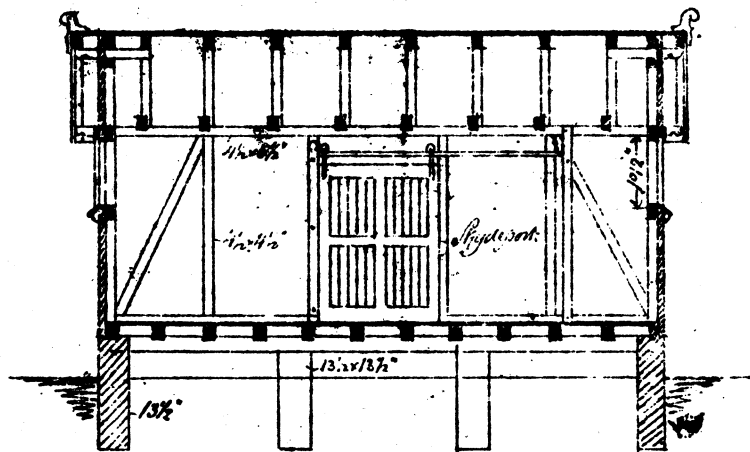

Ferron

Tristed-Ferritslev Banen

*Locomotivomise ved ~~Tristed~~ Ferritslev
1. Maskine.*

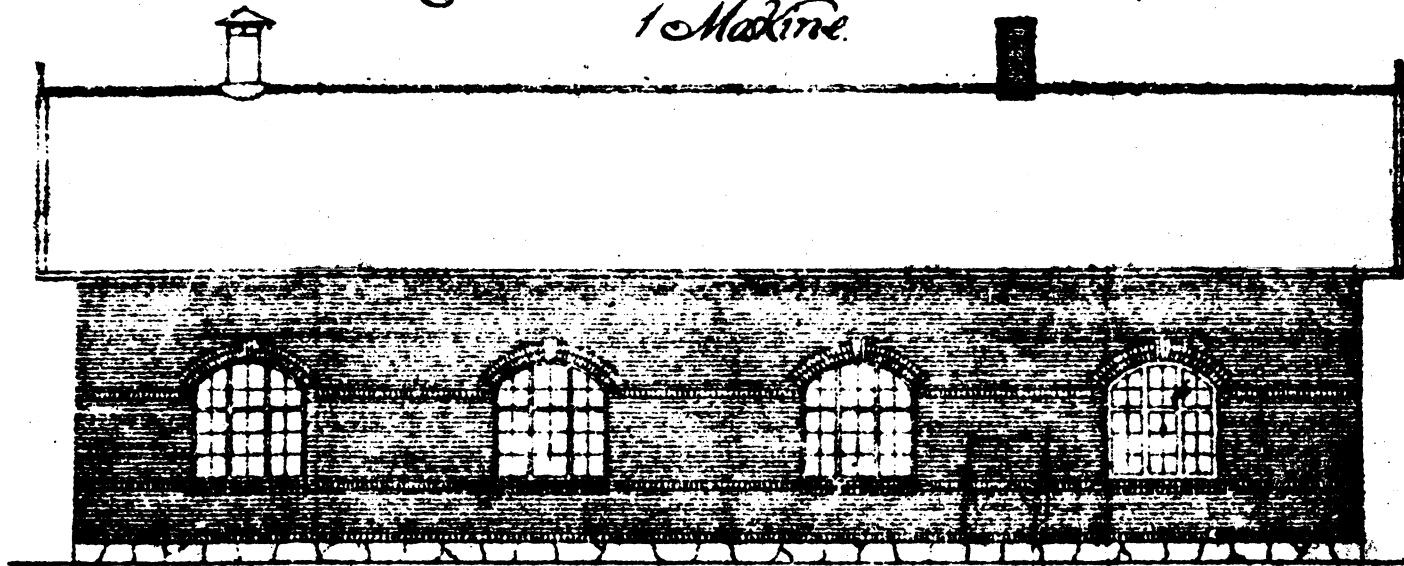

1:100

