

APB 1.

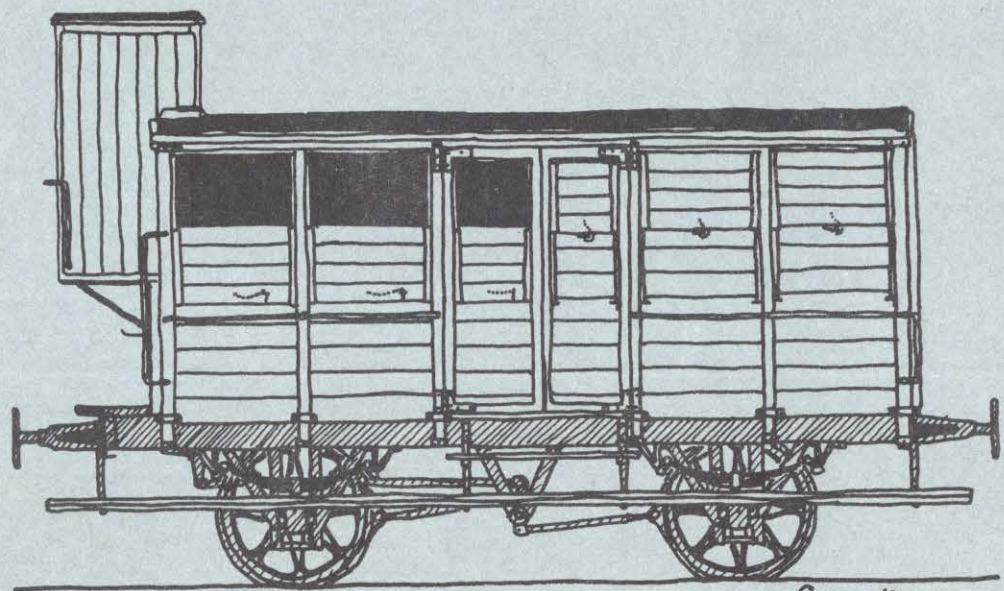

linealis.

Godsvogne

Dette heftes forside skyldes Erik Priess, Kaj Stender og C.A.Lindahl.

JMJKs forlag har tidligere udgivet tegningshæfter om danske privatbaner. Af disse hæfter kan følgende stadig leveres :

ØSJS 2 (godsvogne, bygninger)	35,- kr.
HHJ (rullende materiel, bygninger)	58,- kr.

Dette hæfte kan købes for 48,- kr ved at indbetale beløbet til :

JMJKs Forlag
Nørre Allé 79
8000 Århus C
Giro 1308572

Eget tryk

Forord

Jydsk Modeljernbane Klub vil med dette tegningshefte markere, at klubbens forlag kan fejre 10 års jubilæum.

Udgivelse af tegningshæfter om Aalborg Privatbaners rullende materiel har længe stået på ønskelisten, men indsamlingen af tegninger og oplysninger har været meget tidskrævende. Bl.a. fordi Aalborg Privatbaner gennem årene har ejet så stort et antal vogne. Det medfører også, at tegningshæfterne deles op i 3 bind. Bind 1 omhandler godsvogne, medens bind 2 vil indeholde person-, post- og pakvogne. Endelig vil bind 3 vise banernes trækraft (inkl. skinnerbusser).

Når bind 1 omhandler godsvognene skyldes det, at der i forvejen findes materiale og litteratur om trækraften. Derimod har vognmateriellet - og specielt godsvognene - ikke tidligere været beskrevet særligt indgående.

Mange af oplysningerne om vognene er hentet i Aalborg Privatbaners arkiv, der nu findes på Landsarkivet i Viborg. Derudover har flere personer været behjælpelige med oplysninger. En varm tak rettes derfor til :

Landsarkivet, Viborg (v. Henning Skov)
Erhvervsarkivet, Århus (dele af Scandias arkiv)
H.G.Alkjær, Holte
W.Bay, Randers
H.G.Christiansen, Odense
J.Bruun-Petersen, Ribe
P.Topp Nielsen, Sakskøbing

- og ikke mindst til P.Thomassen, Gentofte, der venligst har udlånt et stort og værdifuldt arkivmateriale.

Trofaste læsere af JMJK's publikationer vil muligvis savne en kort redegørelse for Aalborg Privatbaners historie. Men selv en kort gennemgang af banernes ofte komplicerede historie ville blive så omfattende, at det overskrider de intentioner, der ligger bag udgivelsen af JMJK's tegningshæfter. Historisk interesserede henvises derfor til litteraturlisten.

Århus, august 1987

Niels Jørgen Hansen

Om materieloversigten

I materieloversigten er benyttet litreringen fra APB's driftsmaterielfortegnelse 1923, hvor dette har været muligt. Dog er det oprindelig litra anført. Senere omlitreringer er ikke nævnt, da dette ville blive uhyre omfattende. W.Bays materielliste fra 1957 kan delvis råde bod på denne mangel.

Oprindeligt blev banernes vogne købt til hver enkelt bane og iøvrigt litreret nogenlunde fortløbende. Kort efter århundredskiftet opstod et vist driftsfællesskab mellem banerne. Det skete under navnet Nordjyllands forenede Privatbaner. Efter åbningen af Hjørningbaner duede dette navn ikke længere, og fra 1.april 1915 benyttedes fællesnavnet Aalborg Privatbaner - forkortet til APB.

På trods af driftsfællesskabet blev hovedparten af det rullende materiel stadig anskaffet af de enkelte jernbaneselskaber. Materiellet blev mærket med banens ejendomsmærke, og det blev stadig litreret fortløbende. Iøvrigt blev kun enkelte vogne litreret APB.

Systemet med den fortløbende litrering af godsvognene blev på et tidspunkt uhensigtsmæssig, og det ændredes fra 15.oktober 1915. Herefter blev AHB's og AHJ's godsvogne omlitreret. Foran den oprindelige litrering anførte AHB et 2-tal (T-vognene fik et 3-tal). Ved AHJ anførtes et 4-tal (T-vognene fik et 5-tal).

For vogne anskaffet fra DSB er kun medtaget den litrering vogne havde ved overtagelsen. Yderligere oplysninger kan findes i Dansk Jernbnearkivs storværk "Driftsmateriellet". Henvendelse kan ske til Dansk Jernbanearkiv, Postbox 36, 4990 Sakskøbing.

Desværre har kilderne ikke været samstemmende om vognenes data. For enkelte vogne eksisterer der f.eks. 3-4 ophugningstilladelser over en periode på ca. 20 år !

Under indsamlingen af oplysninger er der samlet væsentlig flere oplysninger, end det har været muligt at bringe i dette hefte. Eventuelle interesserede kan henvende sig hos :

JMJK's Forlag
Nørre Allé 79
8000 Århus C

Om tegningerne

De fleste tegninger er gengivet i skala 1:45. Hvor dette ikke er tilfældet, er det angivet på tegningen.

For flere vogntypers vedkommende er der uoverensstemmelse mellem tegningernes og kildernes angivelse af dimensionerne. På enkelte tegninger er dette markeret med en parentes om litreringen. Det drejer sig dog ofte blot om få centimeters afvigelse i f.eks. vognkassens længde.

Ved indsamlingen af tegninger har flere personer været behjælpelige. En stor tak rettes derfor til :

vognfabrikken Scandia, Randers
ingeniør Jørgen Andersen, tidl. Scandia
Limfjordsbanen - v. E.Hedtoft og K.M.Jacobsen
Asger Christiansen, JMJK
Sv.Aage Christiansen, JMJK
Henning Orlowicz, OMJK
Erik Priess, JMJK

Aalborg Privatbaner

Aalborg Privatbaner bestod af følgende strækninger :

FFJ	: Fjerritslev-Aalborg	åbnet 1897, nedlagt 1969
	Nørresundby-Frederikshavn	åbnet 1899, nedlagt 1968 (Sæby-Frederikshavn nedlagt 1962)
	Dronninglund-Aså	åbnet 1914, nedlagt 1968
ANSJ	: Aars-Nibe-Svendstrup	åbnet 1899, nedlagt 1910
AHB	: Aalborg-Hvalpsund	åbnet 1910, nedlagt 1969
	færgeruten Hvalpsund-Sundsøre	åbnet 1927
AHJ	: Aalborg-Hadsund	åbnet 1900, nedlagt 1969

Forkortelser

AHB	: Aalborg-Hvalsund Jernbane
AHJ	: Aalborg-Hadsund Jernbane
AHTJ	: Aarhus-Hammel-Thorsø Jernbane
ANSJ	: Aars-Nibe-Svenstrup Jernbane
APB	: Aalborg Privatbaner
DJK	: Dansk Jernbane Klub
FFJ	: Fjerritslev-Frederikshavn Jernbane
HB	: Hirtshals Banen
HgJK	: Helsingør Jernbane Klub
HH	: Hjørring Hørby Jernbane
HJJ	: Horsens-Juelsminde Jernbane
HLA	: Hjørring-Løkken-Aabybro Jernbane
HP	: Hjørring Privatbaner
MHVJ	: Mariager-Handest Veteran Jernbane
NFP	: Nordjyllands Forenede Privatbaner
RGGJ	: Ryomgaard-Gjerrild-Grenaa Jernbane
SFJ	: Sydfyenske Jernbane/Sydfyenske Jernbaner
TFJ	: Thisted-Fjerritslev Jernbane
VØ	: Vodskov-Østervraa Jernbane

Fabrikationssteder

APB	: Aalborg Privatbaners værksteder, Aalborg
Arlöf	: Waggonfabrikken Arlöf, Arlöv, Sverige
Breslau	: Gebr. Hofmann & Co., Breslau, Tyskland (nu Polen)
Deutsche Werke	: Deutsche Werke, A/G Werft Kiel, Tyskland
Malines	: Societé Anonyme des Ateliers de Construction, Malines, Belgien
Mørch	: Fabrikant C.C.Mørch, Frederikshavn
Scandia	: Vognfabrikken Scandia, Randers
Vulcan	: Maskinfabrikken Vulcan, Maribo
Werdau	: Sächsische Waggon-Fabrik Werdau, Tyskland
Wismar	: Eisenbahn Verkehrs Actiengesellschaft, Wismar og Berlin, Tyskland
Zypen	: Van der Zypen & Charlier, Köln-Deutsch, Tyskland

Litteraturliste

- Driftsbestyrer Stensballes betænkning (1925)
Kommissionsbetænkning (1949)
APB's vognmateriel (skitser), (1911 og 1916)
APB's driftsmateriel (skematisk), (1906, 1908, 1910 og 1923)
- tillæg til ovenstående
Signalpostens fotohefte 1 - FFJ (1970)
Signalpostens fotohefte 2 - AHB og AHJ (1970)
Signalposten 1969 nr. 6
Signalposten 1970 nr. 1-3
Niels Jensen : Nordjyske jernbaner (1976)
FFJ jubilæumsskrift (1949)
Privatbanekommissionens betænkning (1939)
Privatbanekommissionens betænkning (1954)
W.Bay : Oversigt over driftsmateriel (skitser af materiel), (1952)
W.Bay : Danmarks damplokomotiver (1977)
DJK 22 : Danske jernbaners motormateriel (1968)
H.G.Alkjær m.fl.: Jernbanemotor materiellet fra Triangel (1976)
John Poulsen : Motormateriellet fra udenlandske fabrikker før 1945 (1984)
Jeppe Hansen : Danske jernbanestrækninger 1844- (en bibliografi) (1981)

Durch dies Verzeichnis wird das im Juni 1911 ausgegebene Verzeichnis aufgehoben.

Alphabetisches Verzeichnis

der

Eigentumsmerkmale

der

Eisenbahngüterwagen

der Vereinsbahnen sowie von Nichtvereinsbahnen.



Gültig vom 1. Juli 1914.

Ausgegeben

von der Geschäftsführenden Verwaltung des Vereins.

Berlin, im Juni 1914.

1 Laufende Nr.	2 Eigentumsmerkmale der Wagen		3 Farbe		4 Namen der Eisen- bahnen.
	an den Seitenwänden.	an den Langträgern.	des Wagens.	der An- schriften.	
89	A. H. B.	—	blaugrau oder braun	weiß weiß	Aalborg-Hvalsund E. (Aalborg-Hvalsund Jern- bane, Aalborg.)
10	A. H. J.	—	blaugrau weiß	weiß oder schwarz	Aalborg-Hadsund E. (Aalborg-Hadsund Jern- bane, Aalborg.)
324	F. F. J.	—	blaugrau weiß	weiß oder schwarz	Fjerritslev- Nørresundby- Frederikshavn E. (Fjerritslev-Nørresundby- Frederikshavn Jernbane, Aalborg.)

lukkede godsvoerne

FFJ Ha 400	APB	1905	udr 1952, oph 1955
Ha 401	"	"	udr 1952, oph 1955
Ha 402	"	"	udr før 1954
Ha 403	"	"	udr 1952, oph 1957
H 404	"	"	udr ca 1966
H 405	"	"	udr ca 1965
H 406	"	"	udr 1952, 1958 rep til tørvevogn oph 1969.
H 404 - 406 opb på undervogne fra P 613 - 15.			
H 407	APB	1906	udr 1964
H 408	"	"	udr 1954 - 57, oph 1969?
H 409	Scandia	1907	oph ml 1952 - 56
H 410	"	"	udr 1952, til bafd som cykelskur
H 411	"	"	udr 1951, men rep til bafd, 1969 til DJK (MHVJ).
H 412	APB	"	udr 1966
H 413	"	"	udr 1952, oph 1952 - 56
H 414	Scandia	1910	udr 1966
H 415	"	"	udr 1966
H 416	"	"	udr 1962
H 417	"	"	udr 1962
H 418	"	"	udr 1964
H 419	"	"	udr 1964
<u>H 414 - 19 opb på undervogne fra FFJ Cv 101 - 6.</u>			
AHB H 2421	APB	1906	udr 1961
H 2422	Scandia	1907	oph 1966?
H 2423	APB	"	udr 1952, oph 1952 - 56
H 2424	"	1908	udr før 1957, oph 1964
H 2425	"	"	udr og oph 1966
H 2426	"	"	oph 1965
H 2427	"	"	udr 1952, oph 1952 - 56
AHJ H 4431	APB	1906	udr 1965
H 4432	Scandia	1907	udr 1966
H 4433	APB	"	udr 1967
H 4434	"	1908	udr 1952, til bafd som cykelskur
H 4435	"	"	udr 1952, oph 1963
H 4436	"	"	udr 1963, oph 1965
H 4437	"	"	oph 1959

FFJ I 1101'	Zypen	1899,	til AHB 1932 som Is 3145'', udr 1967
I 1101''	"	"	opr AHB Is 3145'- til FFJ 1932 som Igs 1101'', udr 1966
I 1102'	"	"	til AHB 1932 som Is 3147''- udr ml 1957 - 63
I 1102''	"	"	opr AHB 3147', til FFJ 1932 som Igs 1102'' udr 1966
I 1103	"	"	udr 1969
I 1104	"	"	udr 1967
I 1105	"	"	udr 1968
I 1106	"	"	udr 1967
I 1107	"	"	udr 1968
I 1108	"	"	udr 1969
Is 1109	"	"	udr 1968
Is 1110	"	"	udr 1969
Is 1111	"	"	udr 1969
Is 1112	"	"	udr 1968
Is 1113	"	"	udr 1968?
Is 1114	"	"	udr 1968
Is 1115	"	"	udr 1966
Is 1116	"	"	udr 1966
AHB I 3141	"	"	udr 1969
I 3142	"	"	udr 1968
I 3143	"	"	udr 1969?
I 3144	"	"	udr 1969
Is 3145'	"	"	til FFJ 1932 som Igs 1101''
Is 3145''	"	"	opr FFJ I 1101' - til AHB 1932, udr 1967
Is 3146	"	"	udr 1968
Is 3147'	"	"	til FFJ 1932 som Igs 1102''- udr 1966
Is 3147''	"	"	opr FFJ I 1102' - til AHB 1932, udr 1957-63
Is 3148	"	"	udr 1967
AHJ I 5171	"	"	udr 1968
I 5172	"	"	udr 1968
I 5173	"	"	udr 1960
I 5174	"	"	udr 1968
Is 5175	"	"	udr 1969?
Is 5176	"	"	udr 1969
Is 5177	"	"	udr 1969
Is 5178	"	"	udr 1969

Ovennævnte vogne købt af Deutsche Waggon Leihanstalt 1912, opr alle I, senere ombyggede og omlitrerede adskillige gange. Farver: brun, hvid og grå. Opr uden bremse, senere fors. med håndbremse.

FFJ	K1a 501	APB?	1926	opr åben godsvogn	Ka 501, oph 1962
	K1a 502	"	"	opr åben godsvogn	Ka 502, oph 1964
	K1a 503	"	"	opr åben godsvogn	Ka 503, oph 1952
	K1a 504	Scandia	1924	opr åben godsvogn	Ka 504, 1933/34 omb til E 157, 1969 til HgJK
	K1 505	APB?	1925	opr åben godsvogn	K 505 oph 1949
	K1 506	Scandia	1924	opr åben godsvogn	K 506, oph 1967?
	K1 507	"	"	opr åben godsvogn	K 507, oph 1968
	K1 508	"	"	opr åben godsvogn	K 508, oph 1969
	K1 509	APB?	1925	opr åben godsvogn	K 509, oph 1959
	K1 510	"	"	opr åben godsvogn	K 510, oph 1969?
	K1 511	"	"	opr åben godsvogn	K 511, oph 1969?
	K1 512	"	"	opr åben godsvogn	K 512, oph 1966?
AHB	K1 2531	APB?	1927	opr åben godsv.	K 2531, udr 1968
	K1 2532	"	"	opr åben godsv.	K 2532, udr 1969
	K1 2533	"	"	opr åben godsv.	K 2533, udr 1966
	K1 2534	"	"	opr åben godsv.	K 2534, udr 1968
AHJ	K1 4541	"	1927/28	opr åben godsv.	K 4541, udr 1967
	K1 4542	"	"	opr åben godsv.	K 4542, udr 1968
	K1 4543	"	"	opr åben godsv.	K 4543, udr 1968
	K1 4544	"	"	opr åben godsv.	K 4544, udr 1965?

FFJ	Qa 201	Vulcan	1897	1923 omb. til	hjelpevogn 1
	Qa 202	"	"	udr 1952?	
	Qa 203	"	"	1933 omb til E	156
	Qa 204	"	"	indr. til fisketransp.	1947(Qae 204) udr ca 1955, oph 1963(evt 65)
	Qa 205	"	"	udr 1952, oph	1956
	Qa 201 - 5	opr med bremsehus, fjernet 1908 og kassen <u>forlænget. opr Q 7 - 11</u>			
	Qa 206	Vulcan	1897	omb 1932 til E	158
	Qa 207	"	"	indr. til fisketransport	ca 1947 oml Qae 207, udr før 57, oph 65?
	Qa 208	"	"	udr før 54, oph	1956
	Qa 209	"	"	udr før 57, oph	1962
	Qa 210	"	"	udr før 54, oph	69?
	Qa 211'	"	"	omb 1933 til E	175
	Qa 211''	?	?	meldt udr	1956
	<u>Qa 206 - 211' oprindelig Q 1 - 6</u>				
	Qa 212	Scandia	1898	oph 1933(uheld i Dybvad)	
	Qa 213	"	"	udr før 1952, oph	1963 (evt 65)
	Qa 214	"	"	udr ca 1952, oph	1956
	<u>Qa 212 - 214 oprindelig Q 21 - 23.</u>				
	Q 215	Scandia	1898	udr 54 - 57, oph	1957
	Q 216	"	"	udr 1956, oph	1966
	Q 217	"	"	1928 til TFJ som Q 13'', senere E	3
	Q 218	"	"	oph 1964?	
	Q 219	"	"	oph 1956	
	Q 220	"	"	1959 tørveoplagsvogn, oph	1969
	Q 221	"	"	1952 " " , oph	1966?
	Q 222	"	"	udr før 57, oph	1964
	Q 223	"	"	oph 1966?	
	Q 224	"	"	oph 1966?	
	Q 225	"	"	udr 1965, oph	1969
	Q 226	"	"	oph 1968	
	Q 227	"	"	oph 1969	
	Q 228	"	"	oph 1969	
	<u>Q 215 - 228 oprindelig Q 17 - 20 og 24 - 33</u>				

FFJ Q 229 Vulcan 1899 oph. omkr. 1963
 Q 230 " " oph. 1966?
 Q 231 " " tørveoplagsvogn 1958-64. Oph 1968
 Q 232 " " oph 1962?
 Q 233 " " udr 1952, oph 1956
Q 229 - 233 oprindelig Q 34 - 38.
 Q 234 Scandia 1899 udr 1952, oph 1966
 Q 235 " " udr 1952?, oph 1965
 Q 236 " " oph 1966
 Q 237 " " udr 1963, oph 65?
 Q 238 " " oph 1966?
 Q 239 " " udr 1952, 1957 eks kun undervgn,
 der ophugges
 Q 240 " " oph 1959
 Q 241 " " oph 1963
 Q 242 " " udr 1966
 Q 243 " " udgået 1929
 Q 244 " " oph 1964
 Q 245 " " oph 1964
 Q 246 " " oph 1966?
 Q 247 " " oplagsvogn fra 1952, oph 1966
Q 248 " " udr 1966
 Qf 249 Scandia 1906 udr 1940 efter uheld
 Qf 250 " " udr 1956, oph 1964?
 Qf 251 " " oph 1966
 Qf 252 " " udr 1956, oph 1964
249 - 252 litr Qc fra 1924
 Qb 253 Scandia 1907 oph 1957
 Qb 254 " " udr 1952, oph 1961
 Qb 255 " " udr 1952, oph 1956
 Qb 256 " " oph 1966
 Qb 257 " " oph 1966
 Qb 258 " " oph 1966
253 - 258 opr Q, 1923 Qb, senere både Qc og Qb
 Qf 259 Scandia 1911 oph 1969?
 Qf 260 " " oph 1969?
 Qf 261 " " oph 1969?
 Qf 262 " " oph 1969?
opr Q 259 - 262, 1923 Qf

FFJ Qf 263 Scandia 1914 oph 1969?
 Qf 264 " " oph 1969?
 Qf 265 " " oph 1969?
 Qf 266 " " oph 1969?
 Qf 267 " " oph 1969?
 Qf 268 " " oph 1969?
 Qf 269 " " oph 1969?
 Qf 270 " " oph 1969?
 Qf 271 " " oph 1969?
 Qf 272 " " oph 1969?
 Qf 273 " " oph 1969?
 Qf 274 " " oph 1969?
 Qf 275 " " oph 1969?
 Qf 276 " " oph 1969
 Qf 277 " " oph 1969
 Qf 278 " " oph 1966 efter ulykke, Hørby
 Qf 279 " " oph 1969?
 Qf 280 Scandia 1915 oph 1969
 Qf 281 " " oph 1969?
 Qf 282 " " oph 1969
 Qf 283 " " oph 1969?
 Qf 284 " " oph 1960?
 Qf 285 " " udr mellem 1957 og 1963
 Qf 286 " " oph 1969?
 Qf 287 " " oph 1969?
 Qf 288 " " oph 1969?
 Qf 289 " " 1968 solgt til entreprenør
 Qf 290 " " oph 1969?
 Qf 291 " " oph 1969
 Qf 292 " " 1968 solgt til entreprenør
 Qf 293 " " oph 1969?
 Qf 294 " " oph 1969
 Qf 295 " " oph 1969?
 Qf 296 " " oph 1969?
 Qf 297 " " oph 1969?
 Qf 298 " " oph 1968
 Qf 299 " " oph mellem 1957 og 1963
opr Q 263 - 299, 1923 Qf

FFJ Qf 300	Scandia	1915	oph 1969?
Qf 301	"	"	oph 1969
Qf 302	"	"	oph 1969?
Qf 303	"	"	oph 1969
Qf 304	"	"	oph 1969
Qf 305	"	"	1968 solgt til entreprenør
Qf 306	"	"	oph 1969?
Qf 307	"	"	oph 1969?
Qf 308	"	"	oph 1969
Qf 309	"	"	oph 1969
Qf 310	"	"	oph 1969?
Qf 311	"	1916	oph 1969
Qf 312	"	"	oph 1969
Qf 313	"	"	oph 1969?
Qf 314	"	"	oph 1969
Qf 315	"	"	oph 1969
Qf 316	"	"	oph 1969?
Qf 317	"	1917	oph 1969?
Qf 318	"	"	1941 værkstedsvg. Nr Sundby, udr 1965 - 69.
Qf 319	"	"	oph 1969
Qf 320	"	"	oph 1969
Qf 321	"	"	1968 solgt til entreprenør
Qf 322	"	"	oph 1969?
Qf 323	"	"	oph 1969?
Qf 324	"	"	1968 solgt til entreprenør
Qf 325	"	"	oph 1969?
Qf 326	"	"	oph 1969
Qf 327	"	"	1949 solgt til Frederikshavn værft
Qf 328	"	"	oph 1969?
Qf 329	"	"	oph 1969
Qf 330	"	"	oph 1969?
Qf 331	"	"	oph 1969?
<u>opr Q 300 - 331, fra 1923 Qf</u>			
Qb 332	Vulcan	1904	opr TFJ Q 13, til FFJ 1928, oph 1966?

FFJ Qf 333	Scandia	1911	opr RGGB Q 16, oph 1969?
Qf 334	"	"	opr RGGB Q 15, oph 1969?
Qf 335	"	"	opr RGGB Q 11, oph 1969?
Qf 336	"	"	opr RGGB Q 12, oph 1969
Qf 337	"	"	opr RGGB Q 1, oph 1969
Qf 338	"	"	opr RGGB Q 2, oph 1969?
Qf 339	"	"	opr RGGB Q 3, oph 1969?
Qf 340	"	"	opr RGGB Q 4, oph 1969?
Qf 341	"	"	opr RGGB Q 13, oph 1969?
Qf 342	"	"	opr RGGB Q 14, oph 1969
<u>Qf 333 - 342 til FFJ 1955</u>			
Qf 343	Scandia	1905	opr AHTJ Q 117, oph 1969?
Qf 344	"	"	opr AHTJ Q 130, oph 1969?
Qf 345	"	1903	opr AHTJ Q 105, oph 1969
Qf 346	"	"	opr AHTJ Q 107, oph 1969?
Qf 347	"	1902	opr AHTJ Q 108, oph 1969
Qf 348	"	"	opr AHTJ Q 110, oph 1969?
Qf 349	"	?	opr AHTJ Q 113, oph 1969?
Qf 350	"	1903	opr AHTJ Q 124, oph 1969?
Qf 351	"	"	opr AHTJ Q 125, oph 1969?
Qf 352	Wismar	1914	opr AHTJ Q 126, oph 1969?
Qf 353	"	"	opr AHTJ Q 127, oph 1969
Qf 354	"	1915	opr AHTJ Q 128, oph 1969
Qf 355	"	"	opr AHTJ Q 129, oph 1969?
Qf 356	Scandia	1905	opr AHTJ Q 131, oph 1969
Qf 357	"	1913	opr AHTJ Q 132, oph 1969
<u>Qf 343 - 357 til FFJ 1956</u>			
Qf 358	Scandia	1912	opr SFJ Qb 652, 1913 Qb 415, 1949 DSB Qb 23062, 1951/52 HJJ H 96, 1952 Qb 343, 1957 til FFJ, 1969 til Lars Viinholt Nielsen
Qf 359	Scandia	1908	opr HJJ F 61, 1952 Q 351, 1957 til FFJ, oph 1969?
<u>Qf 360 - 365 til FFJ 1965</u>			
Qf 360	Arlöf	1913	opr HH Q 210(HP Q 100), oph 1969
Qf 361	Werdau	1923	opr VØ Q 302(HP Q 109), oph 1969?
Qf 362	Scandia	1925	opr HB Q 401(HP Q 111), oph 1969
Qf 363	"	"	opr HB Q 402(HP Q 112), oph 1969?
Qf 364	"	"	opr HB Q 403(HP Q 113), oph 1969?
Qf 365	"	"	opr HB Q 408(HP Q 117), oph 1969?
<u>Qf 360 - 365 til FFJ 1965</u>			

FFJ Qf 366 Scandia 1913 opr HLA Q 130 (HP Q 121), oph 1969?
 Qf 367 " " opr HH Q 240 (HP Q 126), oph 1969?
 Qf 368 " " opr HLA Q 113 (HP Q 129), oph 1969?
 Qf 369 " 1916 opr HLA H 902 (HP Q 134), oph 1969?
 Qf 370 " 1913 opr HLA H 906 (HP Q 137), oph 1969?
 Qf 371 " " opr HLA H 907 (HP Q 138), oph 1969?
 Qf 372 " 1916 opr HLA H 908 (HP Q 139), oph 1969?
 Qf 373 " " opr HH H 931 (HP Q 140), oph 1969?
 Qf 374 " 1913 opr HB H 973 (HP Q 141), oph 1969?
 Qf 360 - 374 til FFJ 1965

Qf 375 Scandia 1909 opr DSB Qe 34105, oph 1969
 Qf 376 " " opr DSB Qe 34140, oph 1969
 Qf 377 " 1914 opr DSB Qe 34272, oph 1969
 Qf 378 " " opr DSB Qe 34274, oph 1969
 Qf 379 " " opr DSB Qe 34535, oph 1969
 Qf 380 " " opr DSB Qe 34561, oph 1969
 Qf 381 " " opr DSB Qe 34565, oph 1969
 Qf 382 " " opr DSB Qe 34569, oph 1969
 Qf 383 " 1898 opr DSB Qe1 34061, oph 1969
 Qf 384 " 1909 opr DSB Qe1 34148, oph 1969
 Qf 385 " 1912 opr DSB Qg 33199, oph 1969
 Qf 386 " " opr DSB Qg 33271, oph 1969
 Qf 387 " 1907 opr DSB Qgr 35235, oph 1969
 Qf 375 - 387 til FFJ 1965

FFJ Qs 441 Scandia 1898 udr 1964
 Qs 442 " " udr 1966
 Qs 443 " " udr 1964
 Qs 444 " " udr 1965
 Qs 445 " " udr 1954 - 7, oph 1957?
 Qs 446 " 1899 udr 1968 og solgt til entreprenør
 Qs 441 - 5 opr Qs 12 - 16
 Qe 447 Sc/APB 1923/59 opr Eb 32 (E 180), oph 1969?
 Qe 448 Sc/APB 1913/60 opr E 35 (E 167), oph 1969?

AHB Qf 2301 Vulcan 1899 opr ANSJ Q 66, udr 1969?
 Qf 2302 " " opr ANSJ Q 67, udr 1969?
 Qf 2303 " " opp ANSJ Q 61, udr 1969?
 Qf 2304 " " opr ANSJ Q 62, udr 1969
 Qf 2305 " " opr ANSJ Q 63, udr 1969?
 Qf 2306 " " opr ANSJ Q 64, udr 1969
 Qf 2307 " " opr ANSJ Q 65, udr 1969
 Qf 2304 - 7 omb 1931 til kødvogne Qfk.

Qf 2308 Scandia 1900 udr 1969?
 Qf 2309 " " udr 1969?
 Qf 2310 " 1902 udr 1969
 Qf 2311 " " udr 1969
 Qf 2312 " 1903 udr 1969
 Qf 2313 " " udr 1963, oph 1965?
 Qf 2314 " 1906 udr 1952, oph 1956?
 Qf 2315 " " udr 1952, oph 1956?
 Qf 2316 " 1907 udr 1955
 Qf 2317 " " ituslået på Statsbanen 2/5 1918, udr 1921!
 Qf 2318 " 1911 udr 1969?
 Qf 2319 " " udr 1969?
 Qf 2320 " 1913 udr 1969?
 Qf 2321 " " udr 1969
 Qf 2322 " " udr 1969
 Qf 2323 " 1915 udr 1969?
 Qf 2324 " " udr 1969?
 Qf 2325 " " udr 1969?
 Qf 2326 " " udr 1969
 Qf 2327 " " udr 1969
 Qf 2328 " " udr 1969
 Qf 2329 " " udr 1969?
 Qf 2330 " " udr 1969?
 Qf 2331 " " udr 1969
 Qf 2332 " " udr 1969?
 Qf 2333 " " udr 1969?
 Qf 2334 " " udr 1969?

AHB Qe 2335 Vul./APB 1899/59 opr Eb 56 (E 182), oph 1969?
 Qe 2336 Ar1./APB 1910/59 opr Eb 58 (E 184), oph 1969?

åbne godsvogne

AHJ	Q 4331	Scandia	1900	udr før 1957, oph 1963?
	Q 4332	"	"	udr før 1957
	Q 4333	"	"	udr 1961
	Q 4334	"	"	udr 1961
	Q 4335	"	"	udr 1965
	Q 4336	"	"	udr 1965
	Q 4337	"	"	udr 1965
	Q 4338	"	1904	udr 1966, opr bremsehus
	Q 4339	"	"	1936 br.hus fjernet, udr 1966
	Q 4340	"	"	udr 1969
	Q 4341	"	"	udr 1952, oph 1960?
	Q 4342	"	"	udr 1952, oph før 1963?
	Q 4343	"	"	udr 1964
	Qf 4344	"	1906	udr før 1963
	Qf 4345	"	"	udr 1952, oph 1957?
	Qf 4346	"	1907	udr 1957, oph før 1963?
	Qf 4347	"	"	udr 1966
	Qf 4348	"	1911	udr 1969?
	Qf 4349	"	"	udr 1969?
	Qf 4350	"	1913	udr 1969
	Qf 4351	"	"	udr 1969
	Qf 4352	"	"	udr 1969?
	Qf 4353	"	1915	udr 1968
	Qf 4354	"	"	1968 solgt til entreprenør
	Qf 4355	"	"	udr 1969?
	Qf 4356	"	"	udr 1969?
	Qf 4357	"	"	udr 1969
	Qf 4358	"	"	udr 1969?
	Qf 4359	"	"	udr 1969?
	Qf 4360	"	1917	udr 1969
	Qf 4361	"	"	udr 1969
	Qf 4362	"	"	udr 1968
AHJ	Qs 4461	Scandia	1900	udr 1965
	Qs 4462	"	"	udr 1968
	Qs 4463	"	"	udr før 1954, oph 1955
	Qs 4464	"	1903	udr 1968
	Qs 4465	"	"	1906 omb til E 173
	Qe 4377	APB/APB	1906/64	opr E 77 (E 173), udr 1969?

FFJ	Ka 501	Vulcan	1897	omb 1926 til lukket gv. Kla
	Ka 502	"	"	omb 1926 til lukket gv. Kla
	Ka 503	"	"	omb 1926 til lukket gv. Kla
	Ka 504	"	"	omb 1924 til lukket gv Kla, 1933 E 157
				<u>Ka 501 - 4 opr K 1 - 4</u>
FFJ	K 505	Scandia	1899	omb 1925 til lukket gv. Kl
	K 506	"	"	omb 1924 til lukket gv. Kl
	K 507	"	"	omb 1924 til lukket gv. Kl
	K 508	"	"	omb 1924 til lukket gv. Kl
	K 509	"	"	omb 1925 til lukket gv. Kl
	K 510	"	"	omb 1925 til lukket gv. Kl
	K 511	"	"	omb 1925 til lukket gv. Kl
	K 512	"	"	omb 1925 til lukket gv. Kl
				<u>K 504 - 12 opr K 5 - 12</u>
FFJ	Pa 601	Vulcan	1896	oph 1949. opr bremsehus
	Pa 602	"	"	opr bremsehus, 1912 hbr. udr 52, oph 1954
				<u>Pa 601 - 2 opr P 9 - 10.</u>
	Pa 603	Vulcan	1896	udr 1952, oph 1954
	Pa 604	"	"	fors. m løs snenæse hos Mørk, Fr.havn (plov 1), oph 1962
	Pa 605	"	"	oph 1949
	Pa 606	"	"	udr 1952, oph 1954
	Pa 607	"	"	oph 1949
	Pa 608	"	"	oph 1949
	Pa 609	"	"	oph 1952
	Pa 610	"	"	udr 1952, oph 1954
				<u>Pa 603 - 10 opr P 1 - 8</u>
	Pa 611	Vulcan	1896	udr 1952, oph 1954
	Pa 612	"	"	udr 1952, oph 1954
				<u>Pa 611 - 12 opr P 11 - 12</u>
	P 613	Vulcan	1896	P 613 - 15 omb 1905 til H 404 - 6,
	P 614	"	"	(skulle alligevel have været
	P 615	"	"	hovedrepareret)
				<u>P 613 - 15 opr P 13 - 15</u>
	P 616	Scandia	1899	udr 1952, oph 1954
	P 617	"	"	oph 1955
	P 618	"	"	oph 1962
	P 619	"	"	udr 1954?, oph 1955
	P 620	"	"	oph før 1965

FFJ	P 621	Scandia	1899	oph 1962
	P 622	"	"	oph 1955
	P 623'	"	"	oph 1946
	P 623''	APB	1946	undervogn fra B 62 og ny overdel oph 1956
<hr/>				
				P 616 - 23' opr P 16 - 23
	Pb 771	Scandia	1899	opr bremsehus, 1931 hbr, oph 1962
	Pb 772	"	"	oph 1956
	Pb 773	"	"	oph 1955
	Pb 774	"	"	oph 1955
	Pb 775	"	"	oph 1955
	Pb 776	"	"	oph 1955
	Pb 777	"	"	oph 1962
	Pb 778	"	"	oph 1955
	Pb 779	"	"	oph 1962
	Pb 780'	"	"	oph 1949
	Pf 780''	"	1917	Pf 991 oml til 780 1949, oph 1955
<hr/>				
	Pf 801	Scandia	1898	oph 1957
	Pf 802	"	"	oph 1954
	Pf 803	"	"	oph 1956
	Pf 804	"	"	udr ml 1965 - 69
	Pf 805	"	"	1968 solgt til entreprenør
	Pf 806	"	"	1942 Ma 2 (tørvevogn) oph 1949
	Pf 807	"	"	udr 1952, oph 1954
	Pf 808	"	"	oph 1962
	Pf 809	Vulcan	1899	oph 1966
	Pf 810	"	"	1942 oml Ma 3 (tørvevogn) oph 1949
	Pf 811	"	"	oph 1957
	Pf 812	"	"	udr 1952, oph 1955
	Pf 813	"	"	oph 1957
<hr/>				
				Pf 801 - 13 opr Pl 41 - 53
	Pf 814	Scandia	1900	oph 1956
	Pf 815	"	"	oph 1957
	Pf 816	"	"	oph 1955
	Pf 817	"	"	udr 1952, oph 1955
	Pf 818	"	"	udr ml 1965 - 69
	Pf 819	"	"	udr 1952, oph 1954
	Pf 820	"	"	udr 1952, oph 1955
	Pf 821	"	"	udr 1949?, oph 1955
	Pf 822	"	"	oph 1959
	Pf 823	"	"	udr 1952, oph till 1956, 1959 og 1965
<hr/>				
				opr Pl 814 - 23, 1923 Pf

FFJ	Pf 824	Breslau	1888	opr bremsehus, 1930 hbr, oph 1966
	Pf 825	"	"	" " , 1931 hbr, oph 1962
	Pf 826	"	"	oph 1957
	Pf 827	"	"	oph 1954
	Pf 828	"	"	oph 1949
	Pf 829	"	"	udr 1952, oph 1954
	Pf 830	"	"	oph 1962
	Pf 831	"	"	udr 1952, oph 1954
	Pf 832	"	"	oph 1967
	Pf 833	"	"	oph 1957
	Pf 834	"	"	1942 oml Ma 1 (tørvevogn), oph 1949
	Pf 835	"	"	oph 1962
	Pf 836	"	"	1942 oml Ma 6 (tørvevogn), oph 1949
	Pf 837	"	"	oph 1955
	Pf 838	"	"	udr 1949?, oph 1954
	Pf 839	"	"	oph 1955
	Pf 840	"	"	oph 1942 efter uheld i V. Hassing
	Pf 841	"	"	oph 1954
	Pf 842	"	"	oph 1954
	Pf 843	"	"	oph 1955
<hr/>				
				Pf 824 - 43 opr Pl, til FFJ 1904
	Pf 844	Scandia	1907	oph 1949
	Pf 845	"	"	oph 1962
	Pf 846	"	"	oph 1949
	Pf 847	"	"	1968 solgt til entreprenør
	Pf 848	"	"	1948 ny undervg, udr ml 1965 - 69
	Pf 849'	"	"	oph 1943
	Pf 849''	APB	1943	oph 1967
	Pf 850	Scandia	1911	oph 1957
	Pf 851	"	"	udr 1952, oph 1955
	Pf 852	"	"	oph 1968
	Pf 853	"	"	oph 1956
	Pf 854	APB	1912	oph 1955
	Pf 855	"	"	oph 1962
	Pf 856	Scandia	"	udr 1949
	Pf 857	"	"	udr 1952, oph 1955
	Pf 858	"	"	udr 1952
	Pf 859	"	"	udr 1952, oph 1954
	Pf 860	"	1914	oph 1955
<hr/>				
				Pf 844 - 60 opr Pl, senere både Pl og Pf

FFJ	Pf 951	Scandia	1914	udr ml 1965 - 69
	Pf 952	"	"	1968 solgt til entreprenør
	Pf 953	"	"	oph 1949
	Pf 954	"	"	oph 1959
	Pf 955	"	"	udr 1940 efter uheld på Onsild st
	Pf 956	"	"	oph 1956
	Pf 957	"	"	oph 1965
	Pf 958	"	"	oph 1962
	Pf 959	"	"	udr ml 1965 - 69
	Pf 960	"	"	udr 1952, oph 1954
	Pf 961	"	"	udr ml 1965 - 69
	Pf 962	"	"	oph 1957
	Pf 963	"	"	oph 1967
	Pf 964	"	"	oph 1957
	Pf 965	"	"	oph 1962
	Pf 966	"	"	oph 1956
				<u>Pf 951 - 66 opr P1</u>
	Pf 967	Scandia	1916	oph 1957
	Pf 968	"	"	oph 1955
	Pf 969	"	"	oph 1955
	Pf 970	"	"	oph 1949?
	Pf 971	"	"	udr 1952, oph 1955
	Pf 972	"	"	udr 1960
				<u>Pf 967 - 72 opr P1</u>
	Pf 973	Scandia	1917	udr 1949?, oph 1956
	Pf 974	"	"	1968 solgt til entreprenør
	Pf 975	"	"	oph 1962
	Pf 976	"	"	oph 1957
	Pf 977	"	"	oph 1955
	Pf 978	"	"	udr 1949?, oph 1956
	Pf 979	"	"	oph 1957
	Pf 980	"	"	udr ml 1965 - 69
	Pf 981	"	"	oph 1959
	Pf 982	"	"	oph 1960
	Pf 983	"	"	oph 1957
	Pf 984	"	"	udr 1949?, oph 1956
	Pf 985	"	"	oph 1949
	Pf 986	"	"	oph 1962
	Pf 987	"	"	1942 oml Ma 4(tørvevogn), oph 1949
	Pf 988	"	"	oph 1963

FFJ	Pf 989	Scandia	1917	udr 1952, oph 1955
	Pf 990	"	"	oph 1967?
	Pf 991	"	"	oml 1949 til Pf 780
	Pf 992	"	"	oph 1957
	Pf 993	"	"	oph 1962
	Pf 994	"	"	oph 1955
	Pf 995	"	"	udr 1952, oph 1954
	Pf 996	"	"	oph 1959
	Pf 997	"	"	oph 1955
				<u>Pf 973 - 97 opr P1</u>

FFJ	Pj 1300	Scandia	1911	opr DSB Pf 16304, til FFJ for smadret Pj 1308 (1959), udr 1969?
	Pj 1301	DWK	1923	udr 1968
	Pj 1302	"	"	udr 1969?
	Pj 1303	"	"	udr 1969?
	Pj 1304	"	"	udr 1969?
	Pj 1305	"	"	udr 1969?
	Pj 1306	"	"	1968 solgt til entreprenør
	Pj 1307	"	"	udr 1969?
	Pj 1308	"	"	smadret i Roskilde 1958
	Pj 1309	"	"	1968 solgt til entreprenør
	Pj 1310	"	"	udr 1969?
				<u>Pj 1301 - 10 opr uden bremse, 1926 forsynet m håndbremse</u>

FFJ	Pu 1311	Harkort	1919/20	opr RGGB P 33, 1968 solgt til entrepr.
	Pu 1312	"	"	opr RGGB P 34, udr 1969?
	Pu 1313	"	"	opr RGGB P 37, m. rangerskruebremse udr 1969?
	Pu 1314	"	"	opr RGGB P 31, 1968 solgt til entrepr.
	Pu 1315	"	"	opr RGGB P 32, 1968 solgt til entrepr.
	Pu 1316	"	"	opr RGGB P 35, udr 1969?
	Pu 1317	"	"	opr RGGB P 36, 1969 solgt til entrepr.
				<u>Pu 1311 - 17 til FFJ 1955.</u>

FFJ	Ta 1009	APB	1908	udr 1935
	Ta 1010	"	"	omb til tankvogn 1935?
	Ta 1011	"	"	udr 1935
	Ta 1012	"	"	udr 1929
	Ta 1013	"	"	oph 1949?
	Ta 1014	"	"	oph 1948
	Ta 1015	"	"	udr før 1954
				<u>Ta 1009 - 15 opr T</u>

FFJ	Ta 1016 APB	1908	m bremsehus, udr 1938 (kørt itu) opr T 1016, fra 1932 Tar
	Ta 1024 Scandia	1911	udr før 1954
	Ta 1025 "	"	oph 1949
	Ta 1027 "	1913	udr før 1954
	Ta 1028 "	"	udr 1935 opr T 1024-5, 27-8
	T 1029 ?	1910	udr 1935
	T 1030 "	"	oph 1941
	T 1031 "	"	oph 1941
	T 1032 "	"	udr 1949?
	T 1033 "	"	m skruebremse, udr 1935
	T 1034 "	"	udr 1935
	T 1035 "	"	oph 1941
	T 1036 "	"	udr 1935
	T 1037 "	"	m skruebremse, udr 1935
	T 1038 "	"	oph 1941
	T 1039 "	"	udr 1935
	T 1040 "	"	udr 1935
	T 1041 "	"	udr 1929 (1935?)
	T 1042 "	"	udr 1935
	T 1043 "	"	m skruebremse, udr 1935
	T 1044 "	"	udr 1935
	T 1045 "	"	oph 1941
	T 1046 "	"	udr 1928 (1935?)
	T 1047 "	"	udr 1928
	T 1048 "	"	oph 1941, m skruebremse
	T 1049 "	"	udr 1935
	T 1050 "	"	oph 1941
	T 1051 "	"	oph 1941
	T 1052 "	"	oph 1941

T 1029 - 52 til FFJ 1918, købt af ing. Svendsen. Bortset fra vogne m skruebr. havde øvrige vogne ingen bremse opr. 1923 forsynes de m håndbremse. Alle omb 1926 med større akselafst. 1932 oml: vogne med skruebr til Tar, øvrige Ta

AHB	K 2531 Vulcan	1899	omb 1927 til Kl 2531 (lukket gv)
	K 2532 "	"	" " " Kl 2532 " "
			opr ANSJ K 31 - 2
	K 2533 Scandia	1903	omb 1927 til Kl 2533 (lukket gv)
	K 2534 "	"	" " " Kl 2534 " "
	P 2671 Vulcan	1899	opr bremsehus, udr før 1954
	P 2672 "	"	" " " " , 1926 håndbr, oph 1949?
	P 2673 "	"	1968 solgt til entreprenør
	P 2674 "	"	udr 1952, oph ml 1952 - 56
	P 2675 "	"	oph 1959
	P 2676 "	"	udr 1956
			opr ANSJ P 101 - 6, senere Pc
	P 2677 Scandia	1900	oph 1964
	P 2678 "	"	udr 1956
			senere Pc 2677 - 8
	Pf 2891 Breslau	1888	opr bremsehus, fjernet ml 1937 - 54 udr 1963?
	Pf 2892 "	"	udr ml 1957 - 63
			Pf 2891 - 2 til ANSJ 1904
	Pf 2893 Scandia	1907	udr 1952
	Pf 2894 "	"	oph 1949
	Pf 2895 "	1911	udr 1952
	Pf 2896 "	"	udr ml 1957 - 63
	Pf 2897 APB	1912	udr 1952
	Pf 2898 Scandia	"	udr ml 1965 - 69
	Pf 2899 "	"	1968 solgt til entreprenør
	Pf 2900 "	1913	udr ml 1957 - 63
	Pf 2901 "	"	udr 1966
	Pf 2902 "	"	udr ml 1957 - 63
	Pf 2903 "	"	udr ml 1954 - 57, oph 1957
	Pf 2904 "	"	udr 1956
	Pf 2905 "	"	1968 solgt til entreprenør
	Pf 2906 "	"	1968 solgt til entreprenør
	Pf 2907 "	"	udr 1969
			opr Pl 2891 - 2907

AHB	Pf 2908	Scandia	1917	udr 1960
	Pf 2909	"	"	udr ml 1957 - 63
	Pf 2910	"	"	udr ml 1957 - 63
	Pf 2911	"	"	oph 1949
	Pf 2912	"	"	oph ml 1952 - 56
	Pf 2913	"	"	oph 1962
	Pf 2914	"	"	udr 1969
	Pf 2915	"	"	oph 1962
	Pf 2916	"	"	oph 1957?
	Pf 2917	"	"	udr 1955
				<u>opr Pl 2908 - 17</u>
	Ta 3001	APB	1908	udr 1949
	Ta 3002	"	"	udr 1929
	Ta 3003	"	"	udr før 1954
	Ta 3004	"	"	udr før 1954
				<u>opr T 1001 - 4</u>
	Tf 3017	Arlöf	1910	udr 1952, oph ml 1952 - 56
	Tf 3018	"	"	udr 1961
	Tf 3019	"	"	oph 1962
	Tf 3020	"	"	udr 1952, oph ml 1952 - 56
	Tf 3021	"	"	udr 1961
	Tf 3022	"	"	udr 1967
				<u>opr Tf 1017 - 22</u>
	Ta 3023	Scandia	1911	udr før 1954
	Ta 3029	"	1913	udr 1946 efter uheld i Aalborg
				<u>opr T 1023 + 1029</u>

AHJ	K 4541	Scandia	1900	omb 1927 til Kl 4541 (lukket gv)
	K 4542	"	"	" " " Kl 4542 " "
	K 4543	"	"	" " " Kl 4543 " "
	K 4544	"	"	" " " Kl 4544 " "
	Pf 4701	Scandia	1900	oph 1956
	Pf 4702	"	"	oph 1956
	Pf 4703	"	"	oph 1949
	Pf 4704	"	"	oph 1956
	Pf 4705	"	"	1942 oml Ma 5 (tørvevogn) oph 1949
				<u>opr P 701 - 5, senere Pc</u>
	Pf 4861	Scandia	1900	udr 1955, oph 1956
	Pf 4862	"	"	oph 1956?
	Pf 4863	"	"	oph 1956
	Pf 4864	"	"	oph 1956
	Pf 4865	"	"	udr 1952, oph 1956
				<u>opr P 861 - 5</u>
	Pf 4866	Malines	1889	udr 1952, oph 1956
	Pf 4867	"	"	udr 1957, oph 1957?
	Pf 4868	"	"	udr 1955, oph 1956
	Pf 4869	"	"	udr 1952, oph 1956
	Pf 4870	"	"	udr ml 1957 - 63
	Pf 4871'	"	"	oph 1949
				<u>Opr Pl 866 - 71, til AHJ 1902</u>
	Pf 4871''	Scandia	1913	opr NTJ K 55, til AHJ 1941, 1949
				påmalet 4871, udr 1952, oph 1956
	?	"	"	opr NTJ K 56, til AHJ 1941, tils.
				ikke oml, udr 1952, oph 1952?
	Pf 4872	Breslau	1888	opr bremsehus, fjernet 1930, oph 1949
	Pf 4873	"	"	udr 1952, oph 1956
	Pf 4874	"	"	oph 1956
				<u>opr Pl 872 - 4, til AHJ 1904</u>
	Pf 4875	Scandia	1907	udr ml 1957 - 65
	Pf 4876	"	"	udr ml 1957 - 65
				<u>opr P 875 - 6, senere Pl og Pf</u>
	Pf 4877	Scandia	1911	oph 1956
	Pf 4878	"	"	oph 1956?
				<u>opr Pl 877 - 8, senere P</u>

AHJ	Pf 4879	Scandia	1912	udr ml 1965 - 69
	Pf 4880	"	"	oph 1959
	Pf 4881	"	"	oph 1956
	Pf 4882	APB	1912	udr ml 1957 - 63
	Pf 4883	Scandia	1913	oph 1956
	Pf 4884	"	"	oph 1956
	Pf 4885	"	"	udr 1952, oph 1956
	Pf 4886	"	"	oph 1961
	Pf 4887	"	"	oph 1957
	Pf 4888	"	"	udt 1952, oph 1956
	Pf 4889	"	"	udr 1967, oph 1968
	Pf 4890	"	"	oph 1957?
	Pf 4921	"	1913	udr ml 1965 - 69
	Pf 4922	"	"	udr ml 1965 - 69
	Pf 4923	"	"	udr ml 1965 - 69
				<u>opr Pl 879 - 923, 1919 P</u>
	Pf 4924	Scandia	1917	udr 1967, oph 1968
	Pf 4925	"	"	1968 solgt til entreprenør
	Pf 4926	"	"	oph 1959
	Pf 4927	"	"	oph 1957?
	Pf 4928	"	"	udr 1955, oph 1956
	Pf 4929	"	"	udr ml 1957 - 63
	Pf 4930	"	"	oph 1962
	Pf 4931	"	"	oph 1957?
	Pf 4932	"	"	udr ml 1965 - 69
	Pf 4933	"	"	udr 1955, oph 1956
	Pf 4934	"	"	udr 1967, oph 1968
	Pf 4935	"	"	udr ml 1957 - 63
				<u>opr Pl 4924 - 35, 1919 P</u>
	Ta 5005	APB	1908	udr før 1954
	Ta 5006	"	"	oph 1941
	Ta 5007	"	"	udr før 1954
	Ta 5008	"	"	opr bremsehus, udr 1935
				<u>opr T 1005 - 8</u>
	T 5009	?	1910	oph 1941
	T 5010	"	"	opr skruebremse, udr før 1954
	T 5011	"	"	udr 1935..
	T 5012	"	"	oph 1941
	T 5013	"	"	udr 1935
	T 5014	"	"	udr 1935

AHJ	5015	?	1910	opr skruebremse, udr før 1954
	5016	"	"	oph 1941
	5017	"	"	oph 1941
	5018	"	"	opr skruebremse, udr før 1954
	5019	"	"	oph 1941
	5020	"	"	oph 1941
				T 5009 - 20 til AHJ 1918, opr ingen
				bremse (bortset fra 10, 15 og 18), 1919
				<u>forsynet m håndbremse</u>
	Ta 5026	Scandia	1911	oph 1949
	Ta 5030	"	1913	udr 1935
				<u>opr T 1026 + 1030</u>

snepløve tankvogne m.m.

FFJ	1	Mørk	1897	løs sneplov til P 604, oph 1962
	2	Vulcan	1900	sneplov, udr ml 1959 - 69
AHB	3	Scandia	1900	" , udr ml 1959 - 69
AHJ	4	Vulcan	1901	" , udr ml 1959 - 69
FFJ	5	Scandia	1925	" , udr ml 1959 - 69
FFJ	T 1010	APB?	1935	opr ballastvogn T 1010?, 1935 fors.
				m tank, 1969 til MHVJ
FFJ	T 1011	Ålb.Værft	1941	opr tankvogn fra DDPA, ny tank påsat
				på Ålborg Værft, 1969 til OHJ, oph 1985?
APB	1	APB?	1923	hjelpevogn, opr Qa 201, udr 1947
	2	"	1945-7	" , opr B 35, 1969 solgt til HP
APB	Ta 1801	APB?	1941	opr tankvogne fra DDPA: Ze 502101,
	Ta 1802	"	"	502113, 502114, 502117, 502140,
	Ta 1803	"	"	502141, 502150. Tankene blev fjernet,
	Ta 1804	"	"	og vognene blev forsynet m tørvehæk
	Ta 1805	"	"	under krigen. En af vognene blev for-
	Ta 1806	"	"	modentlig til T 1011.
	Ta 1807	"	"	De øvrige blev udr 1952

LUKKEDE GODSVOGNE

3

bane	lfr.	nr.	anfal	aksels m	last t	bdfl. m ²	tara kg	bremse			bygget år	bem.
								RS	HB	TL		
FFJ	Q	218,20,21,23,24,26,27,28	8	3,0	10	11,2	5150	x			98	
"	"	229,30,32	3	"	"	11,4	5600	x			99	
"	"	236-38,40-42,44-N ₂₈	10	3,1	"	12,5	5500	x			99	
"	QC	251,256,257,258	4	3,7	"	15,4	6700	x			06-07	
"	QF	259-263	5	3,66	12,5	16,3	7400	x	x		11-14	
"	"	264-277	14	"	"	"	6400	x	x		14	
"	"	278-326	49	"	"	"	6300	x	x		14-17	
"	"	328,329	2	"	"	"	6300	x	x		17	
"	"	330,331	2	"	"	"	7400	x	x		17	
"	QB	332	1	"	10	15,3	6700	x			04	
"	QF	333-336	4	3,66	12,5	16,3	6900	x	x		11	tidl RGGJ
"	"	337-339	3	"	"	"	7700	x	x		"	
"	"	340-342	3	"	"	"	6900	x	x		"	
"	"	343,344	2	"	"	"	7700	x	x		05	tidl AHTJ
"	"	345-357	13	"	"	"	7000	x	x		02-15	
FFJ	H	404,405	2	3,7	10	13,9	7100	x			05	
"	"	407	1	"	"	14,2	7300	x			06	
"	"	412,414-419	7	"	"	14,3	6600	x			07-10	
"	QS	441-444,446	5	4,0	10	13,4	6700	x		x	98	redmalet, slytgods
"	KL	506-512	7	3,5	12,5	15	5600	x	x		99	
"	IGS	1101-1103	3	4,0	12,5	18,6	8800	x	x		99	hvidmalet, is
"	ISK	1104-1106	3	"	"	"	8200	x	x		"	
"	IGS	1107	1	"	"	"	10600	x	x		"	is
"	"	1108,1109	2	"	"	"	9300	x	x		"	is
"	ISK	1110	1	"	"	"	8200	x	x		"	
"	IGS	1111-1116	6	"	"	"	9400	x	x		"	is
AHB	QF	2301-03	3	3,66	12,5	17,1	6600	x	x		99	
"	QI	2304-07	4	"	"	16,1	6800	x	x		"	hvidmalet
"	QIK	2308,09	2	"	"	16,2	6900	x	x		00	
"	QF	2310-13	4	"	"	17,2	6400	x	x		02,03	
"	QC	2314,15	2	3,7	10	16,2	6600	x			06	
"	"	2316	1	"	"	15,5	6800	x			07	
"	QF	2318	1	3,66	12,5	16,3	7300	x	x		11	
"	"	2319-34	16	"	"	"	6300	x	x		11-13	
"	H	2421,22,25,26	4	3,7	10	14,2	7000	x			06-08	
"	KL	2531-34	4	3,5	12,5	"	5800	x			99-03	
"	IS	3141,42	2	4,0	12,5	18,6	7800	x	x		99	hvidmalet
"	"	3143-48	6	"	"	"	7400	x	x		"	
AHJ	Q	4333-39	7	3,1	10	13,3	5400	x			00-04	
"	"	4340-43	4	"	"	12,4	6200	x			04	
"	QB	4344,46	2	3,7	"	16,3	6100	x			06	
"	"	4347	1	"	"	15,4	6100	x			07	
"	QF	4348-55	8	3,66	12,5	16,3	7300	x	x		11-15	
"	"	4356	1	"	"	"	7500	x	x		15	
"	"	4357-59	3	"	"	"	6300	x	x		"	
"	"	4360-62	3	"	"	"	6200	x	x		17	
"	H	4431-33,35-37	6	3,7	10	14,2	6700	x			06-08	
"	QS	4461,62,64	3	4,1	"	"	7000	x		x	00	redmalet, slytgods
"	KL	4541-44	4	3,5	12,5	15,1	5600	x	x		00	
"	IS	5171,72	2	4,0	12,5	18,6	6600	x	x		99	hvidmalet
"	"	5173-78	5	"	"	"	7400	x	x		"	

ÅBNE GODSVOGNE

4

bane	lfr.	nr.	anfal	aksels m	last t	bdfl. m ²	ladeg. m	sideh. m	tara kg	bremse			bygget år	bem.
										H	TB	TL		
FFJ	PC	618	1	3,7	12,5	16,4	6,5	0,765	5400	x			99	
"	"	620,21	2	"	"	"	"	"	5600	x			"	
"	"	771	1	"	"	16,2	6,46	"	5500	x			"	
"	"	777,79	2	"	"	"	"	"	5900	x			"	
"	PF	804,5,9,11,13,15,18,22	9	4,2	"	18,0	7,5	"	5500	x			98-04	
"	"	824,25	2	"	"	"	"	"	5500	x			04	
"	"	826,30,32,35	4	4,0	"	18,1	7,4	0,780	5300	x			04	
"	PL	945	1	4,2	10	18,0	7,5	0,715	5300	x			07	
"	PF	847,48,49	3	"	12,5	"	"	"	5900	x			"	
"	"	852	1	"	"	"	7,66	0,730	5900	x			11	
"	"	855	1	"	"	"	7,5	0,720	5900	x			12	
"	"	951,52	2	"	"	"	7,66	0,730	5900	x	x		14	
"	"	954,57,58,59	4	"	"	"	"	"	5900	x	x		"	
"	"	961,963,965	3	"	"	"	"	"	5600	x	x		"	
"	"	967,72,4,5,6,8,11,2,3	9	"	"	18,1	7,7	"	5900	x	x		16	
"	"	986,88,90,93,96	5	"	"	"	"	"	5900	x	x		17	
"	PJ	1301,02	2	4,0	15	18,0	6,82	1,0	8200	x	x		23	
"	"	1303-10	8	"	"	"	"	"	7300	x	x		"	1313 rangstruckr.
"	PU	1311-17	7	3,5	"	14,9	5,3	1,3	8700	x	x		20	
AHB	PC	2673,75,77	3	3,66	12,5	16,2	6,41	0,9	5600	x			99-00	
"	PF	2891,92	2	4,0	"	18,1	7,44	0,78	5800	x			04	
"	"	2896	1	4,2	"	18,0	7,66	0,73	5900	x			11	
"	"	2898,99,2900,01,02	5	"	"	"	"	"	5900	x	x		12-13	
"	"	2905,06,07	3	"	"	"	"	"	6600	x	x		13	
"	"	2908	1	"	"	18,1	7,7	"	6000	x	x		17	
"	"	2909,10,13,14,15	5	"	"	"	"	"	6200	x	x		17	
"	TF	3010,19,21,22	4	3,76	"	17,3	7,55	0,35	5600	x			10	
AHJ	PF	4870	1	4,0	"	18,1	7,4	0,84	6000	x			99	
"	PL	4875,76	2	4,2	10	18,0	7,5	0,715	5800	x			07	
"	PF	4879,00,82,86,89	5	"	12,5	"	7,66	0,73	5600	x			11-13	
"	"	4921,22,23	3	"	"	"	"	"	6800	x	x		17	
"	"	4924,25,26,29,30	5	"	"	"	"	"	5700	x	x		17	
"	"	4932,33,34,35	4	"	"	18,1	7,7	"	5600	x	x		17	

SPECIALVOGNE

bane	lfr.	nr.	aksels m	tara kg	bremse			år	bem.
					H	TB	TL		
FFJ	-	-	4,8	3000	x	x		hjelpevogn	
FFJ	C	14	5,7	10500	x	x	99	telegrafvogn	
"	"	16	"	"	x	x	98	Smeden Nk	
"	"	1	7300				97	sneplov	
"	"	2	12+24				00	"	
AHB	"	3	"				00	"	
AHJ	"	4	"				01	"	
FFJ	"	5	"				25	"	
"	T	1010	3,5	7200	x	x	08	tankvogn 6000 l	
"	"	1011	3,56	7980	x	x		" 15000 l	

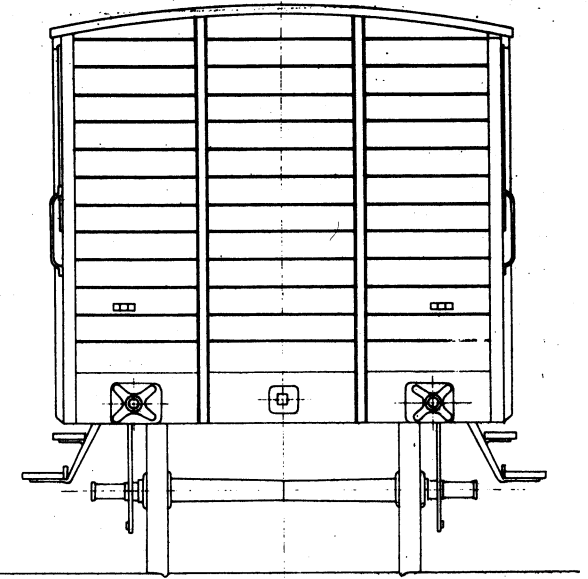
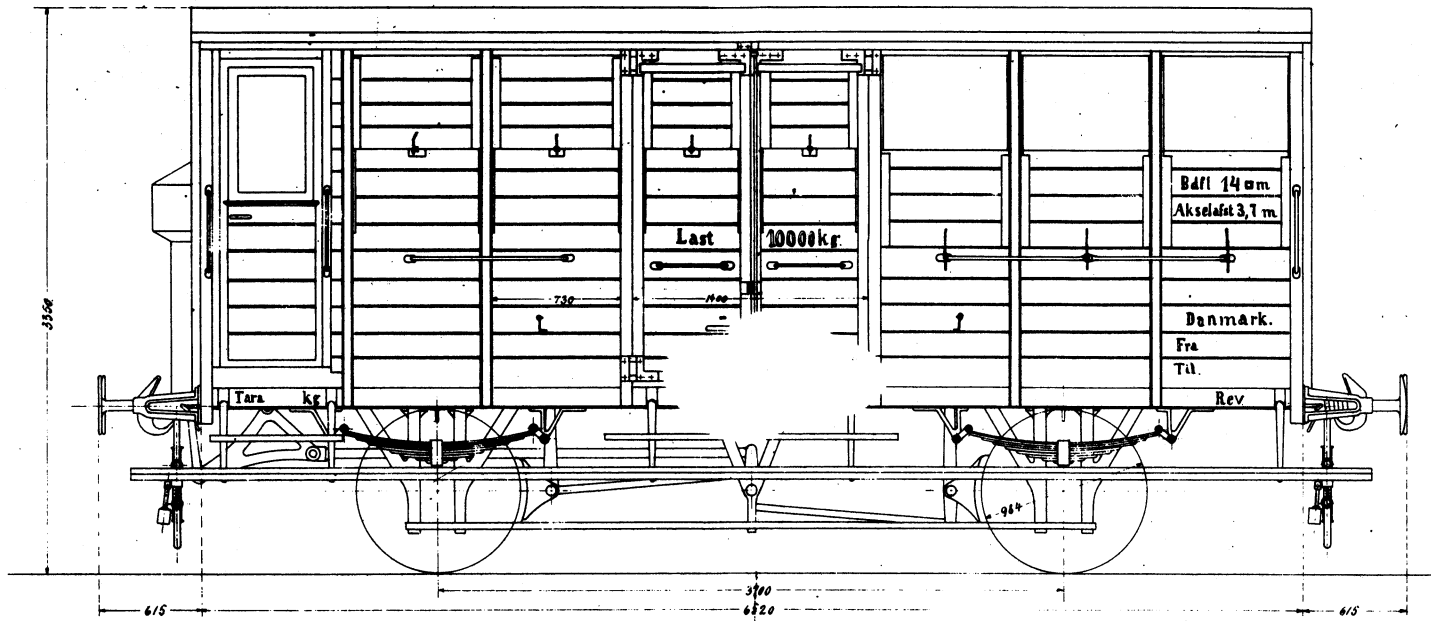

Nordjyllands forenede Jernbaner.

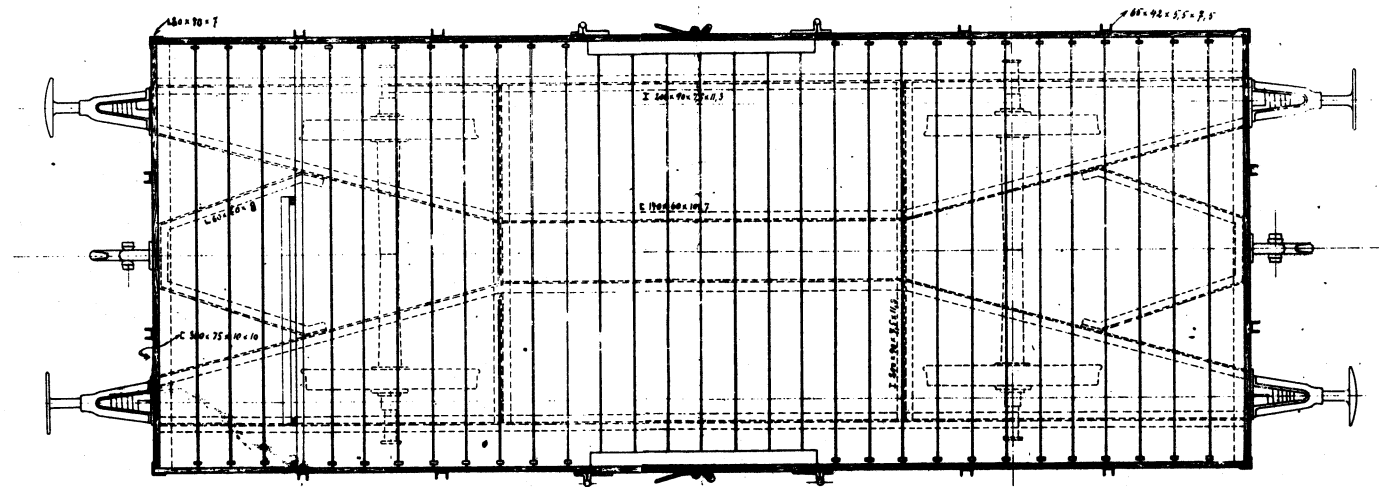

Lukket Godsvogn

Litra S.

i sand Sk.

København Oktober 02

projekttegnning

FFJ H 400-408 og 412-413

AHB H 2421 og 2423-2427

AHJ H 4431 og 4433-4437

(vognene H 412-413 og H 2423 samt 4433 havde højere lemme)

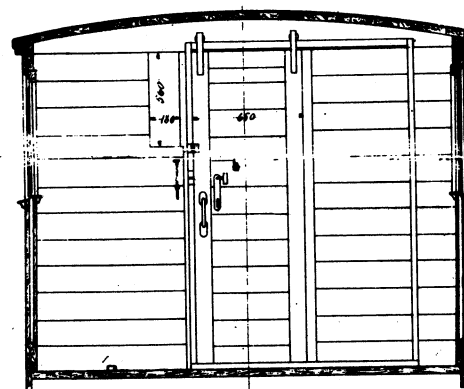
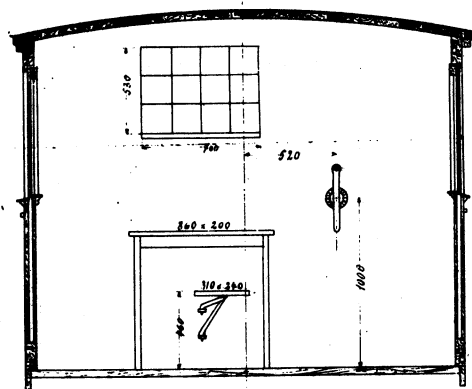
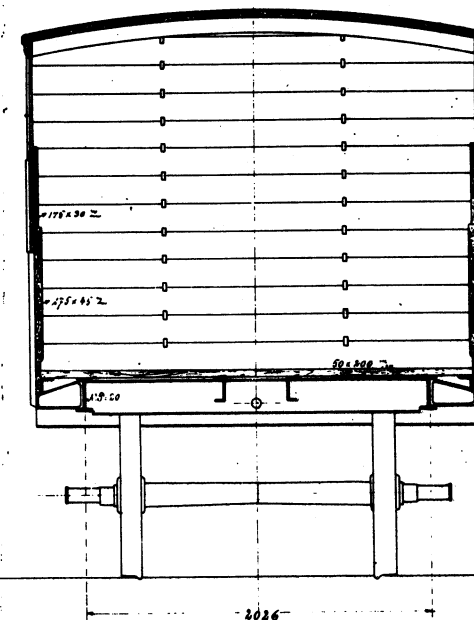
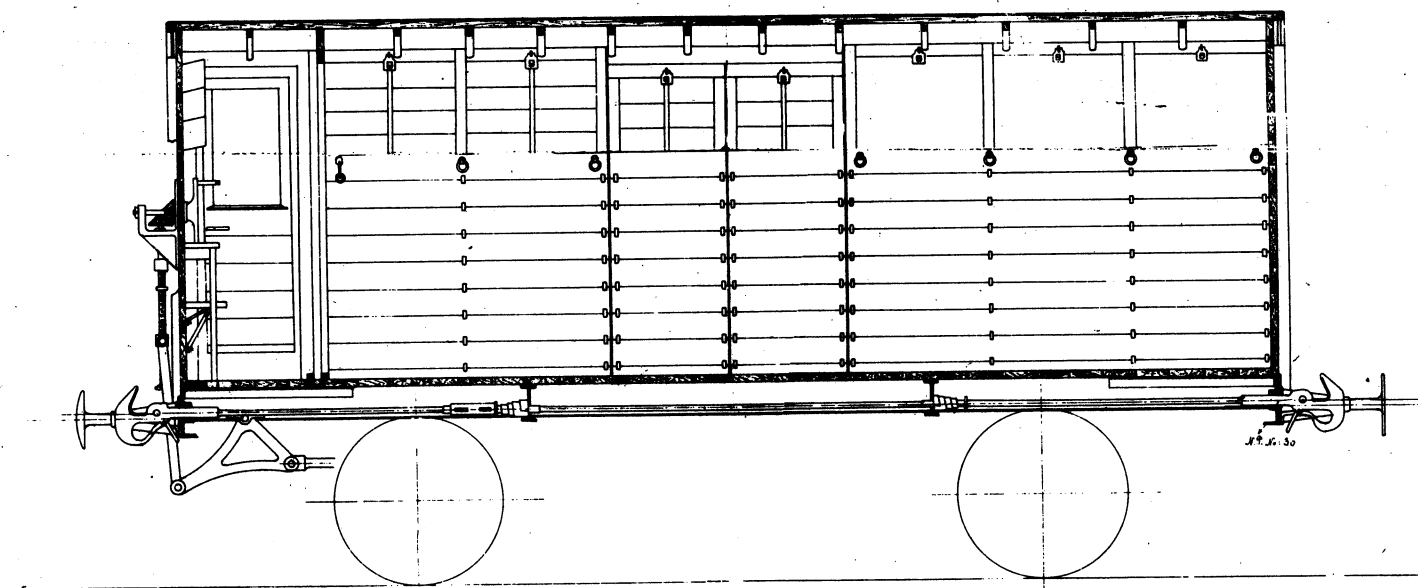

projekttegnig

FFJ H 400-408 og 412-413

AHB H 2421 og 2423-2427

AHJ H 4431 og 4433-4437

(vognene H 412-413 og H 2423 samt 4433 havde højere lemme)

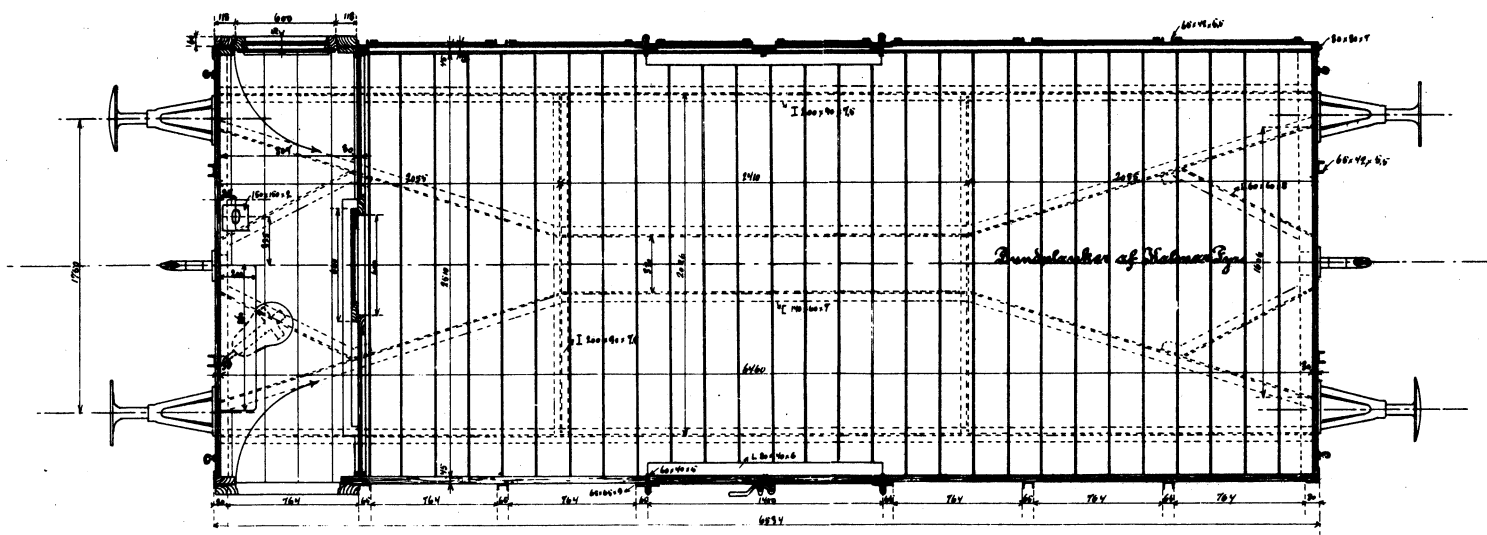
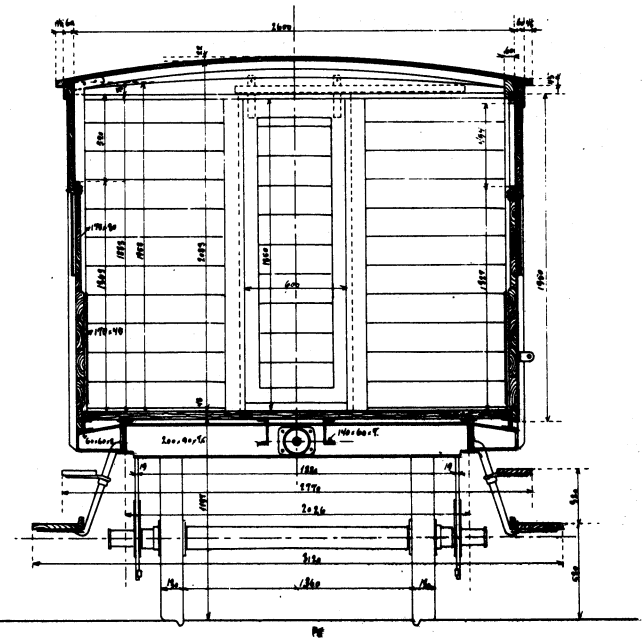
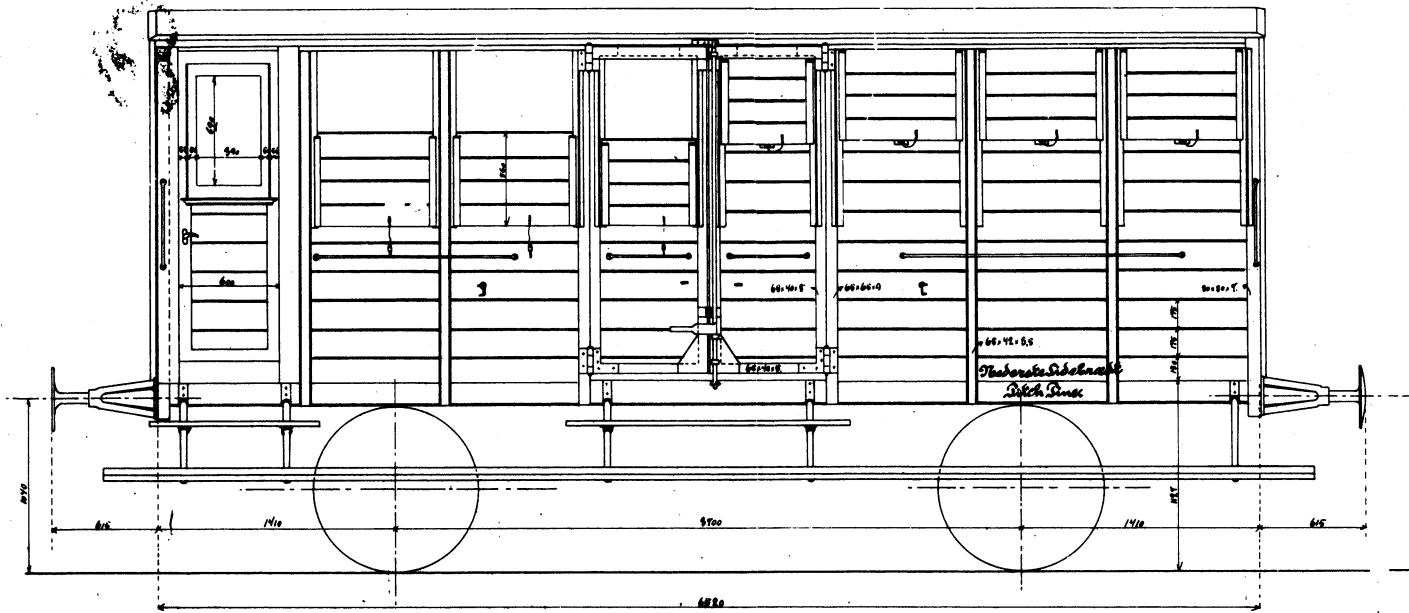

Lokket Godsvagn
 til
 Nordjyllands forenede Banebaner
 Ordre 669.

Scandia 1-2-07

FFJ H 409-411
 AHB H 2422

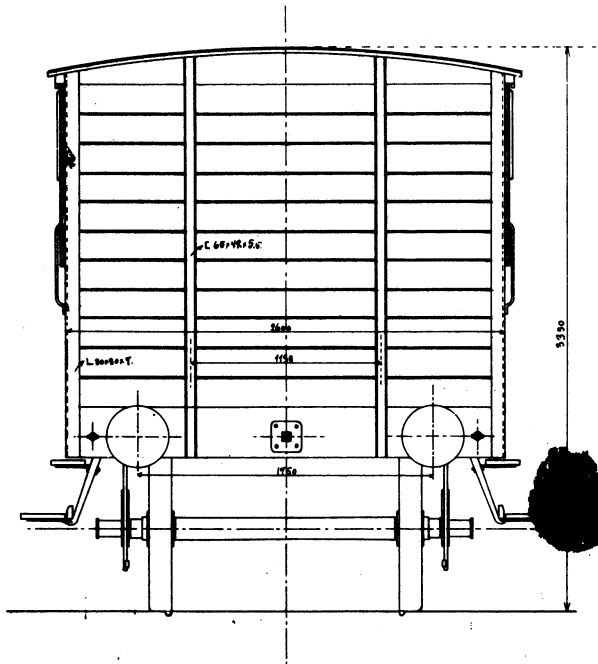
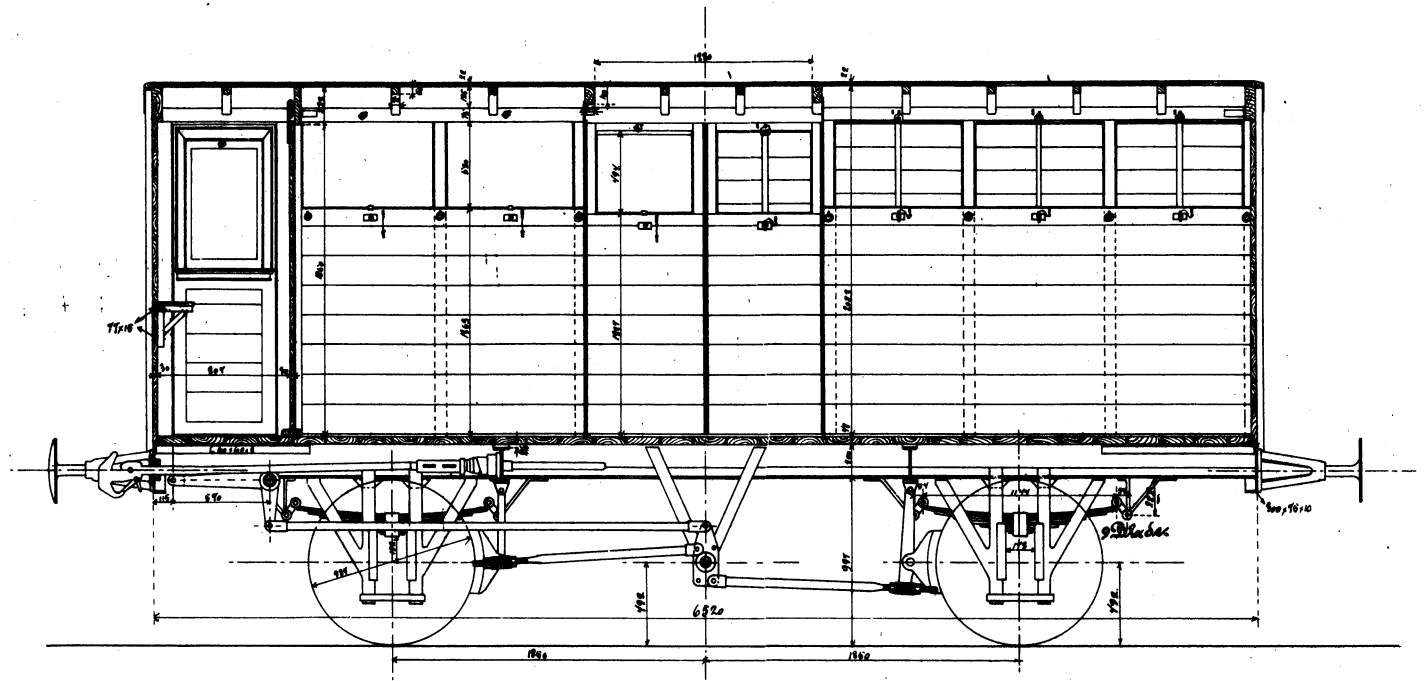
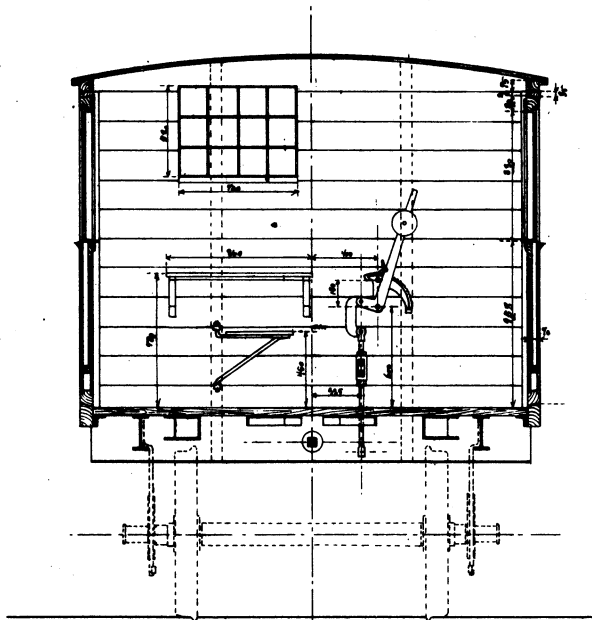

FFJ H 409-411

AHB H 2422

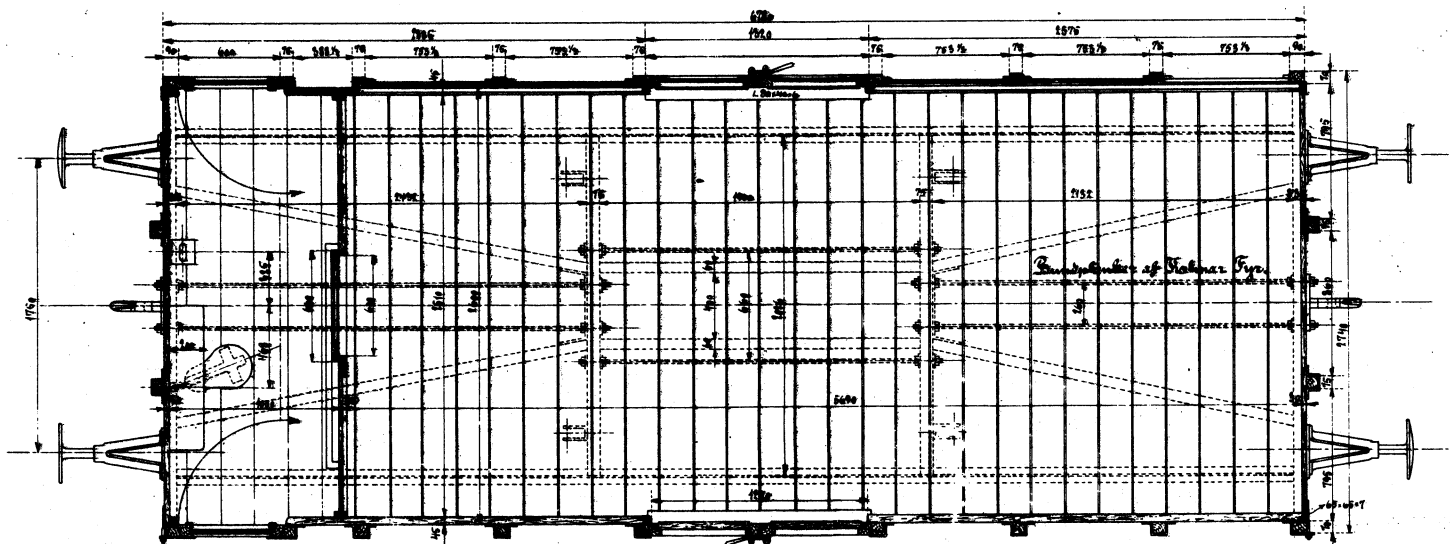
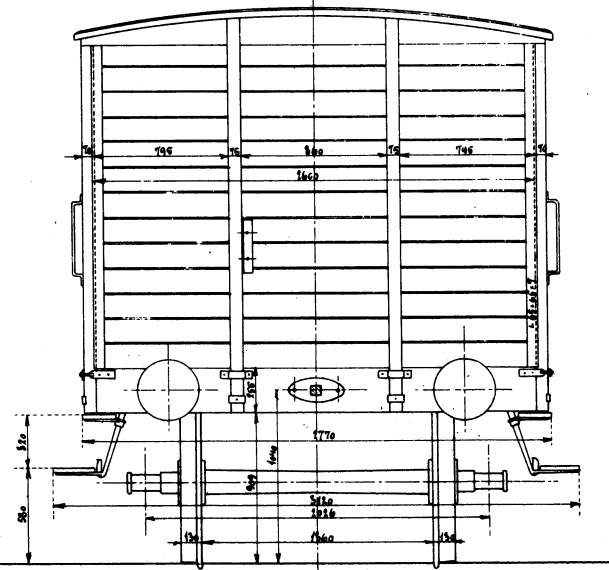
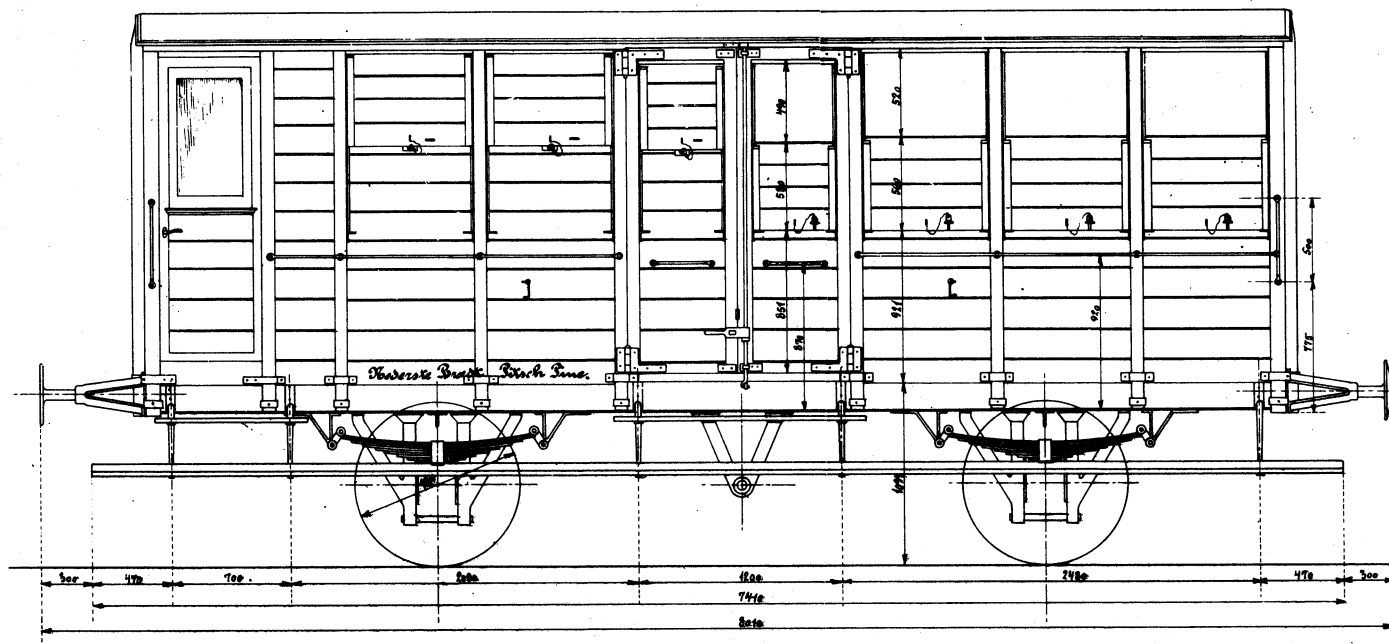

Lukket Godsvogn bygget paa Under-
vognen af Fædelvognen Tegning 6452.
Nordjyllands forenede
Privatbaner.
Ordre

Scandia 20-7-09
H. H. H.

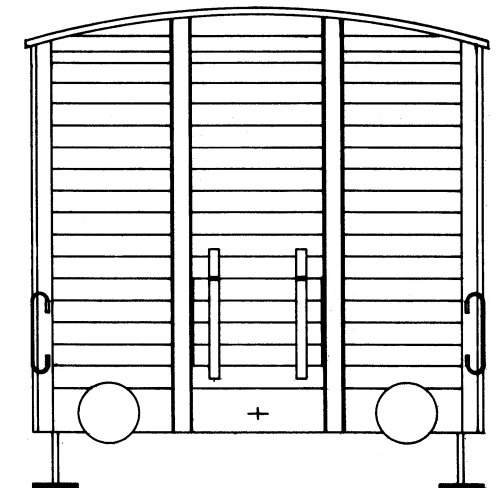
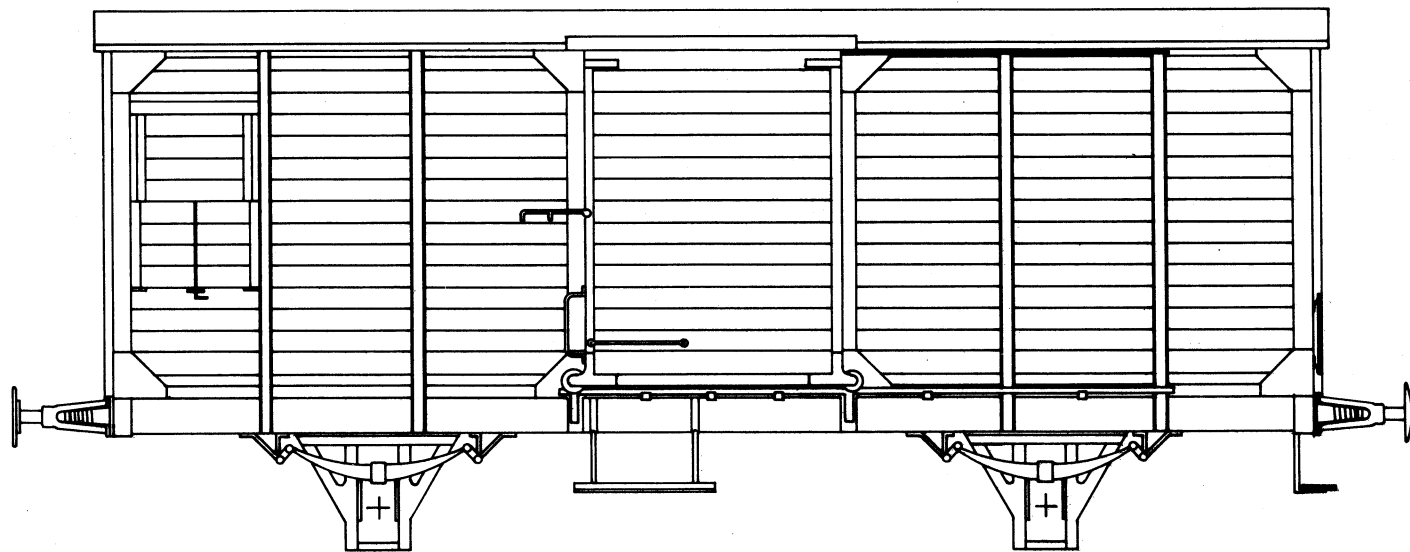

Vognnummer	Farve	Lemme	Gavlen	Bremse	Døre	"KØDVOGN"
FFJ IGS 1101	h	-	-	t	f	-
- - 1102	h	-	-	t	f	+
- - 1103	h	-	-	t		
- IS 1104	h	+	-	t	s	-
- - 1105	h	+	-	h	s	-
- ISK 1106	h	+	+	h	s	+
- IGS 1107	h	-	-	t	f	-
- - 1108	h	-	-	h	f	-
- - 1109	h	-	-	h		
- ISK 1110	h	+	-	h	s	-
- IGS 1111	g	-	-	h	f	-
- - 1112	g	-	-	h	f	-
- - 1113	h	-	-	h	f	-
- - 1114	h	-	-	h		
- - 1115	h	-	-	h	f	+
- - 1116	h	-	-	h		
AHB IS 3141	h	-	-	t	s	-
- - 3142	h	-	-	t	s	-
- - 3143	h	-	-	h		
- - 3144	h	-	-	h		
- - 3145	h	+	+	h	s	-
- - 3146	h	-	-	h		
- - 3147	h	-	-	h		
- - 3148	h	+	-	h	s	-
AHJ IS 5171	h	-	-	t		
- - 5172	h	-	-	t		
- - 5173	h	-	-	h		
- - 5174	h	-	+	h	s	-
- - 5175	h	-	-	h		
- - 5176	h	-	-	h	s	-
- - 5177	h	-	-	h	s	-
- - 5178	h	-	-	h	s	-

Tegnet med ufuldstændig originaltegning som grundlag.

Skemaet er opstillet med div. fotografier som dokumentation.
 Blanke felter = manglende oplysninger.
 Bemærk, at alle vogne har 2 trin ved den ene gavl, og ingen ved den anden. Håndbremsede vogne har bremseklods længst væk fra trin.

h = hvid vognkasse med sort påskrift
 g = grå - - hvid -

t = trykluftbremse
 h = håndbremse og trykluftledning

s = skydedør som vist på tegning
 f = fløjde (som f.eks. ltr. Q, men samme dørkonstruktion, omend smallere, som den viste skydedør)

"KØDVOGN" = påskrift på dør(e), rød, højde ca. 200 mm, placeret med bogstavoverkant ca. 300 mm fra dørøverkant

- FFJ I 1101-1108
- FFJ Is 1109-1116
- AHB I 3141-3144
- AHB Is 3145-3148
- AHJ I 5171-5174
- AHJ Is 5175-5178

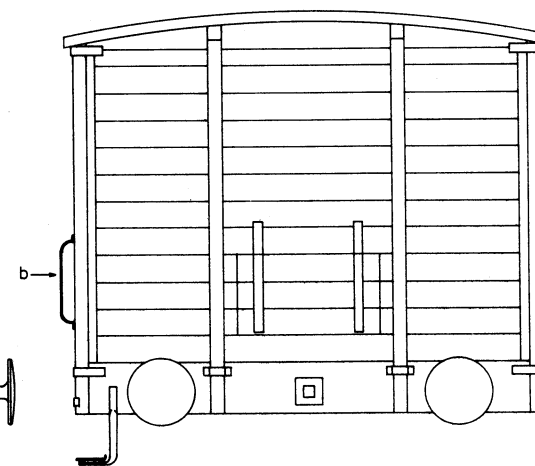
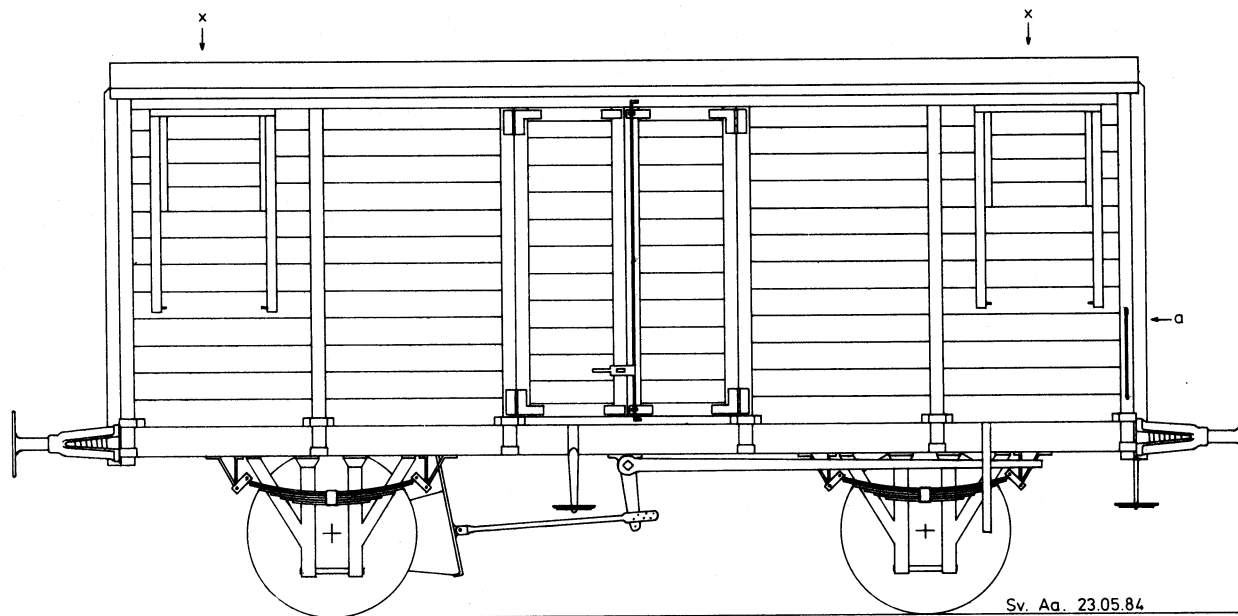

Trin og håndbøjle ved begge gavle

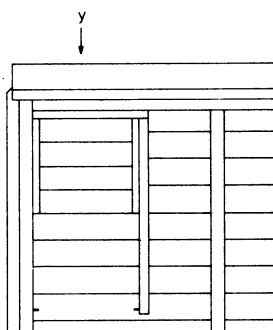

Denne tegning's grundlag er:
originaltegning fra Scandia
skitse til ombygning fra APB
div. fotografier

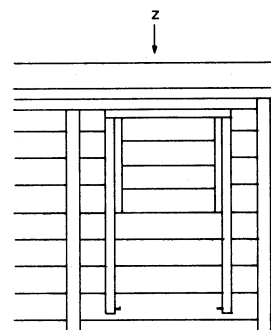

Fotografisk dokumentation viser følgende:

Vognnummer	Sidelemme	Gavllem	Håndgreb
FFJ Kl 507	z	+	b
- - 510	x	+	b
- - 511	x	+	b
AHB - 2534	y	÷	a
AHJ - 4541	z	÷	a
- - 4542	z	÷	b
- - 4544	y	÷	b

Vognene har stjerneegerhjul; dog er AHJ Kl 4542 set med pladehjul i 1967

FFJ Kl a 501-504

FFJ Kl 505-512

AHB Kl 2531-2534

AHJ Kl 4541-4544

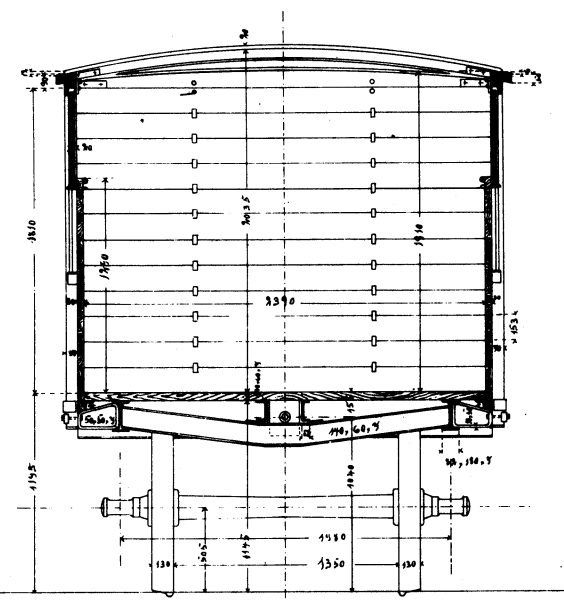
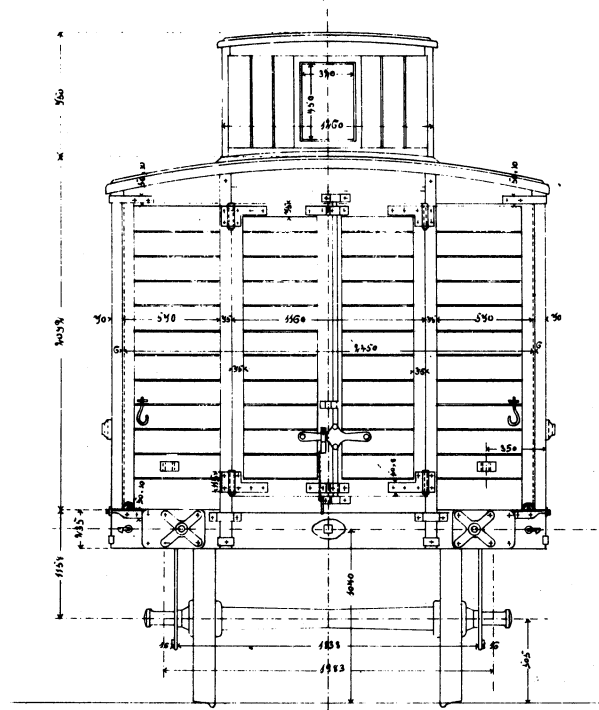
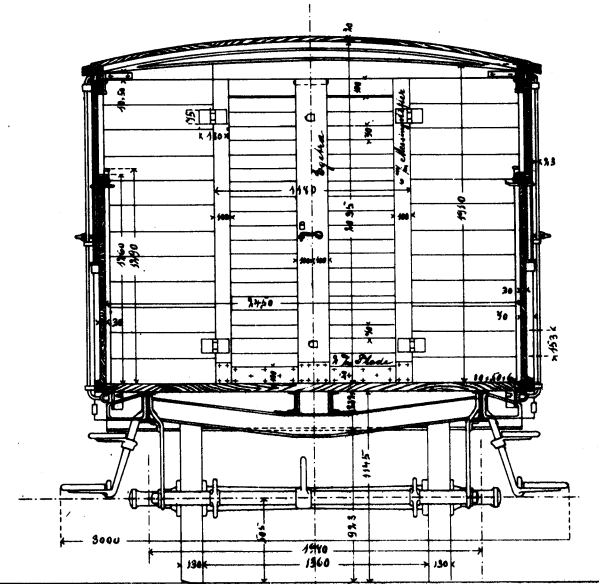
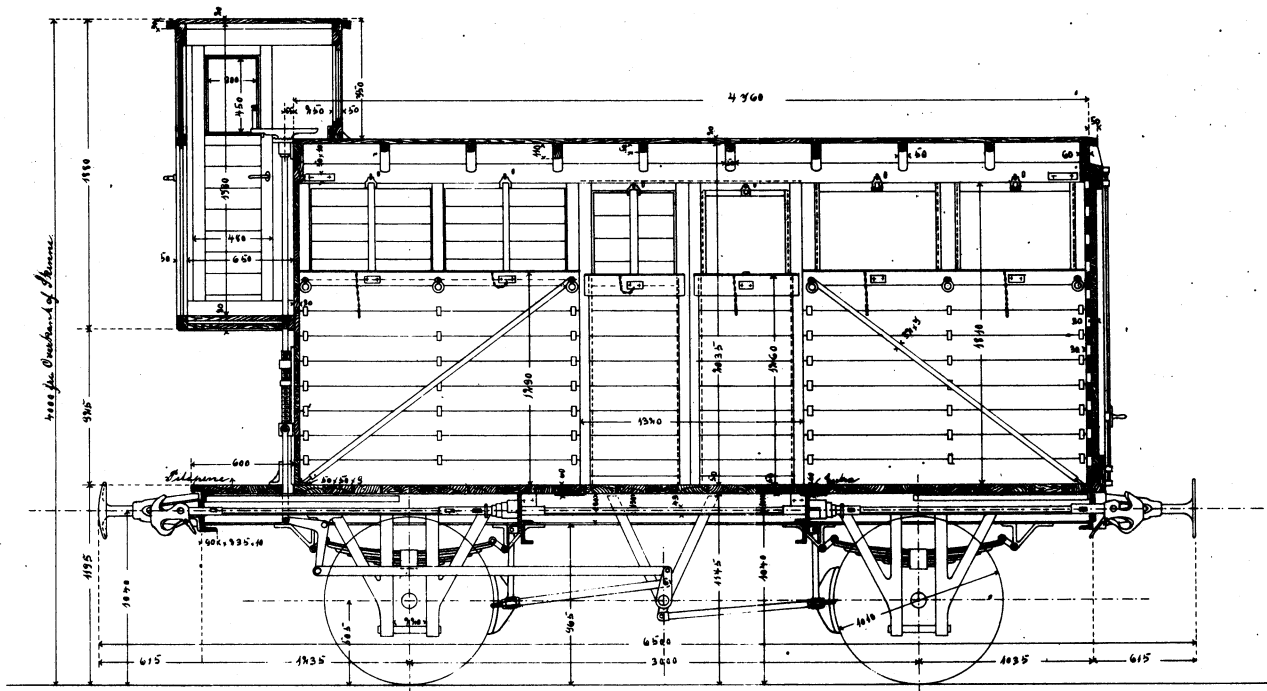

Lukket Gods- og Hægvogn
 med Skuebremse
 Bæreevne 150 Ctr. Bundflade 11,20^m

Mbarilo Juli 1896.

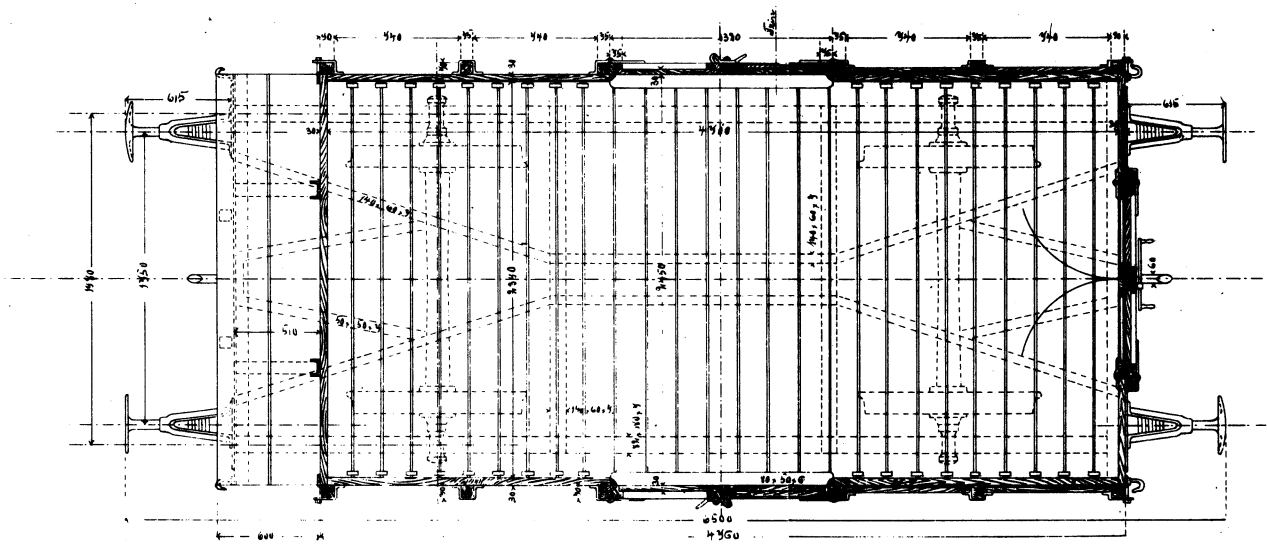
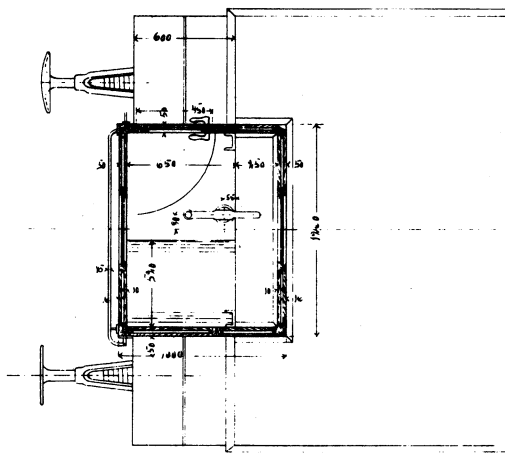
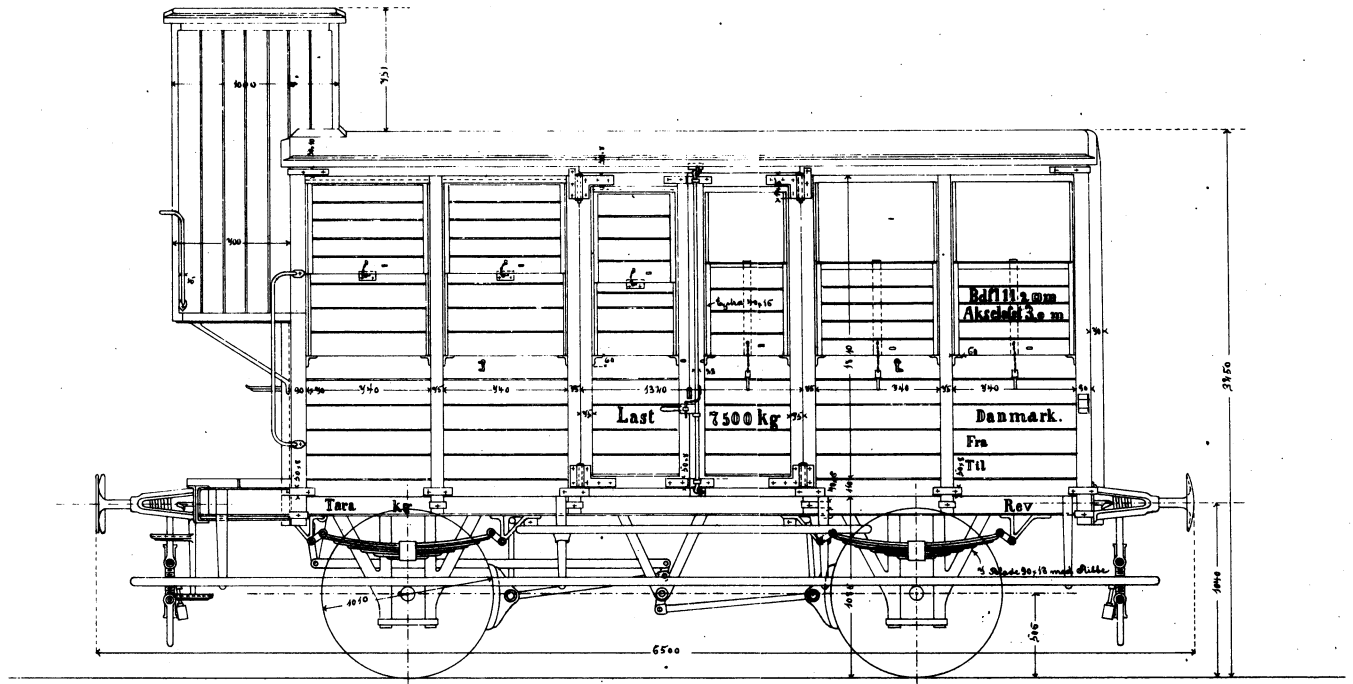
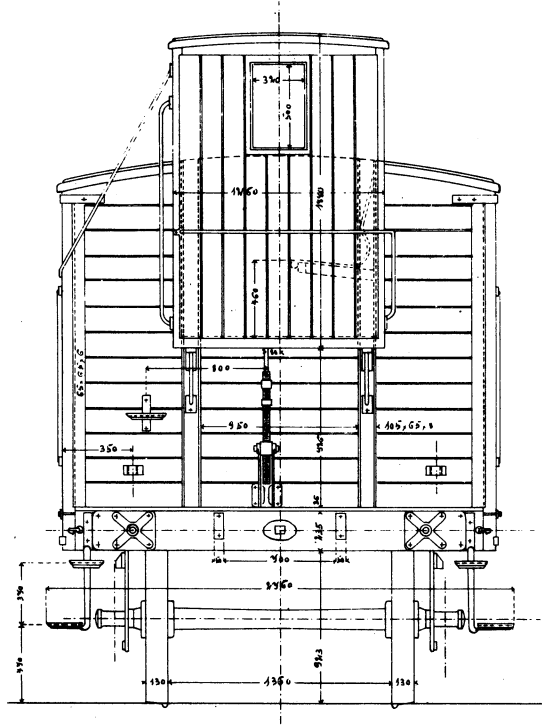

125.

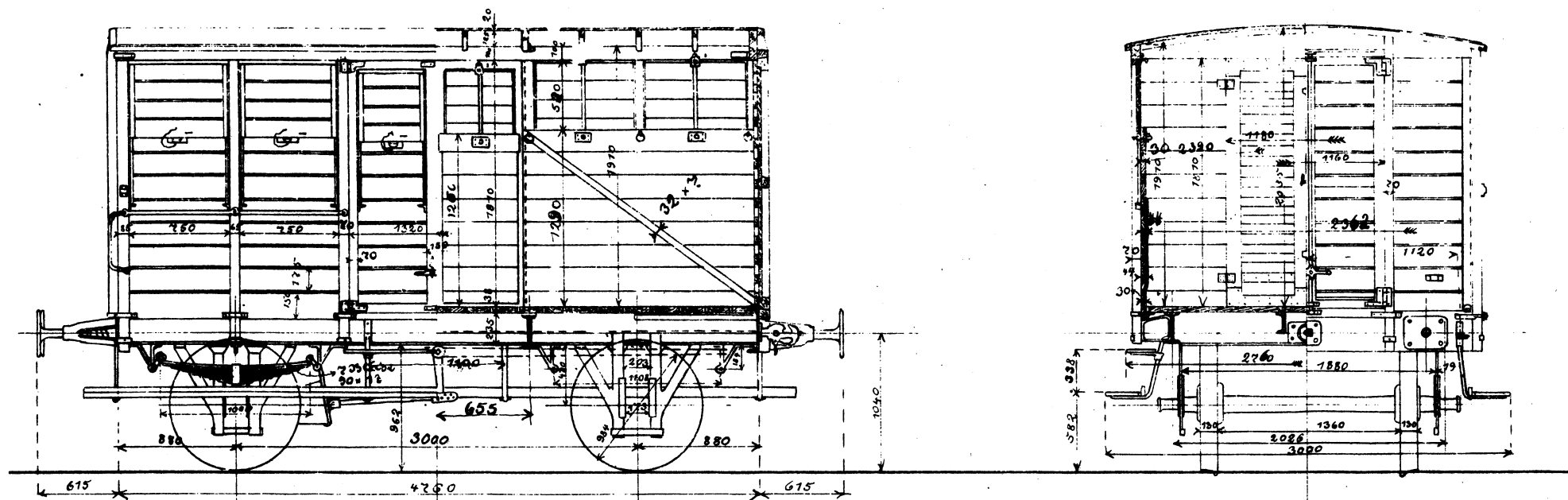

Lukket Godsvoagn.
 til
 Høeresundby - Sæby - Ban.

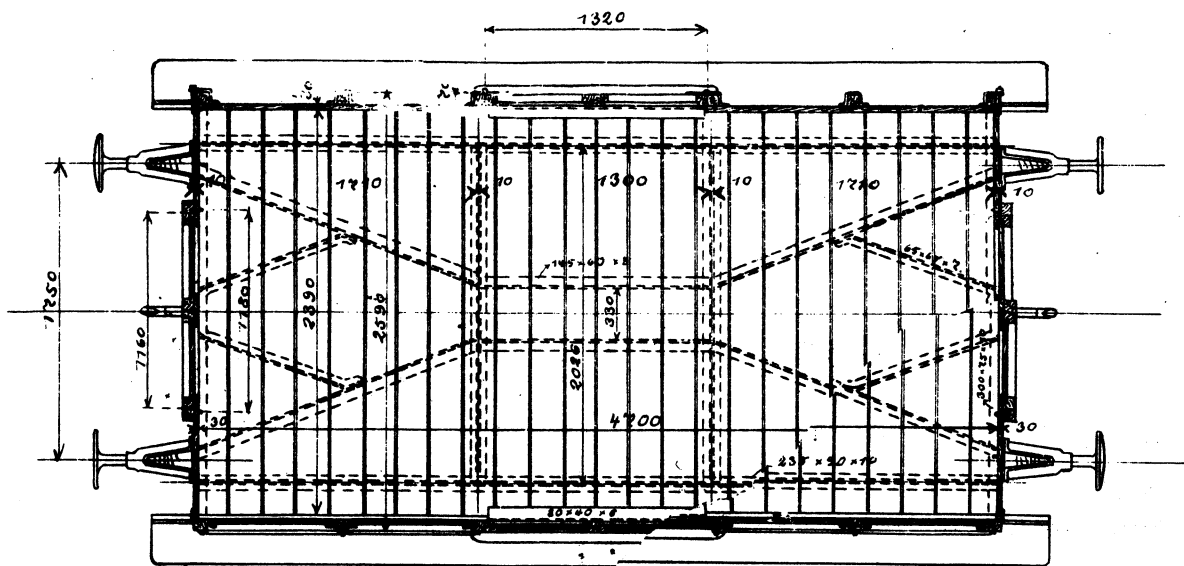

Scandia 1897
 Konstruktøren
 d 3/2 98
 Biehn

tilbudstegning

FFJ Q 215-218 (219-228)

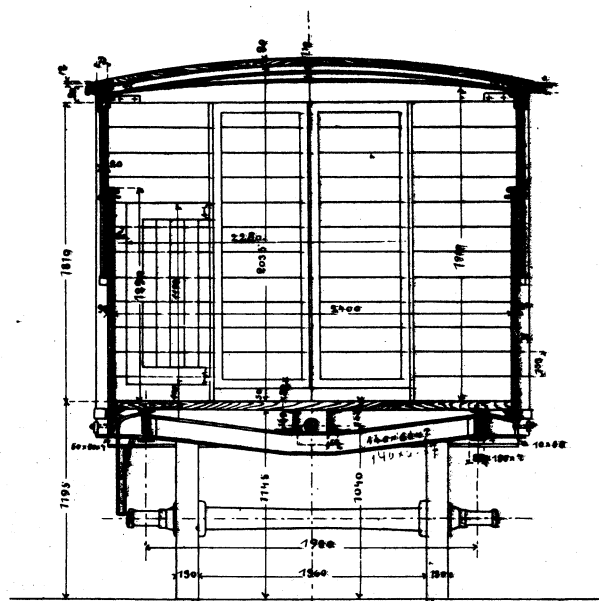
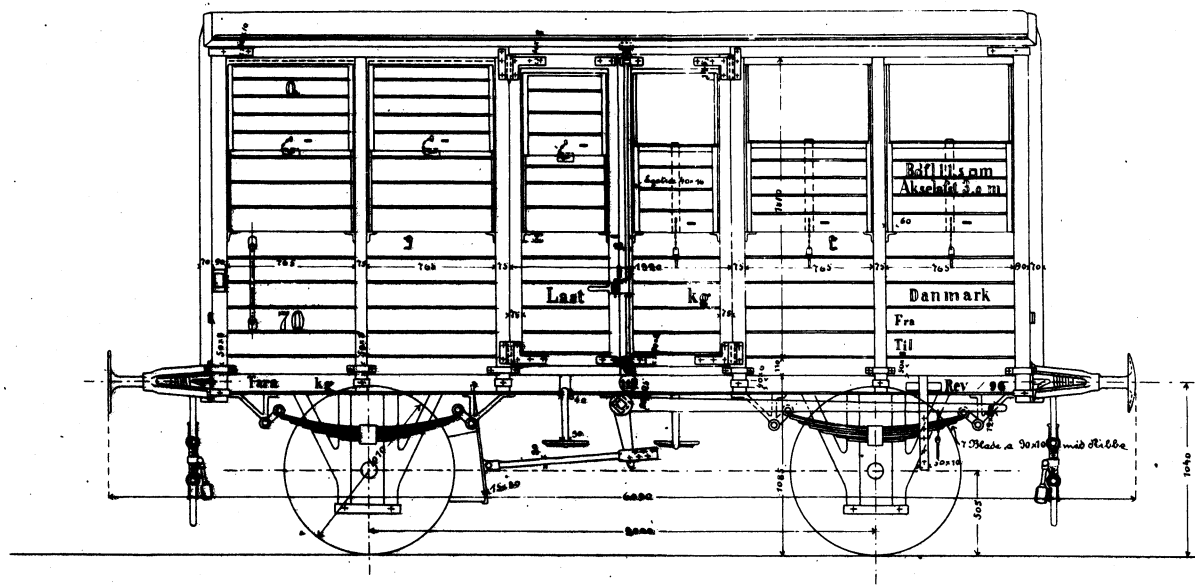
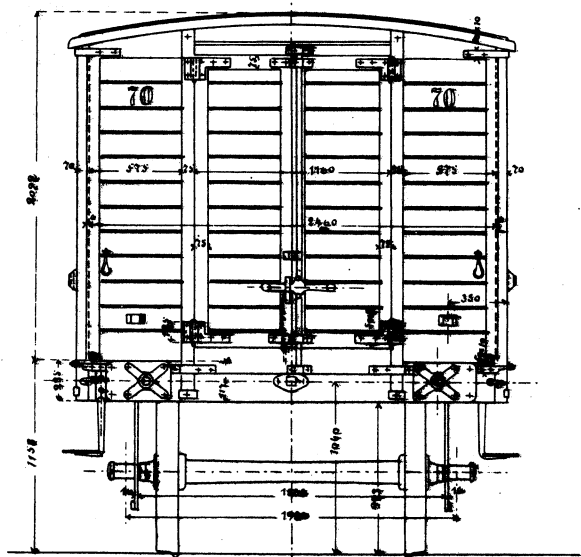

Lukket Gods- og Kvægvogn.
 med Haandbremse
 Bæreevne 160 Ctn: Bundslade 11,5 m

Skarbo den 2/2 1896

196.

FFJ Q 229-233

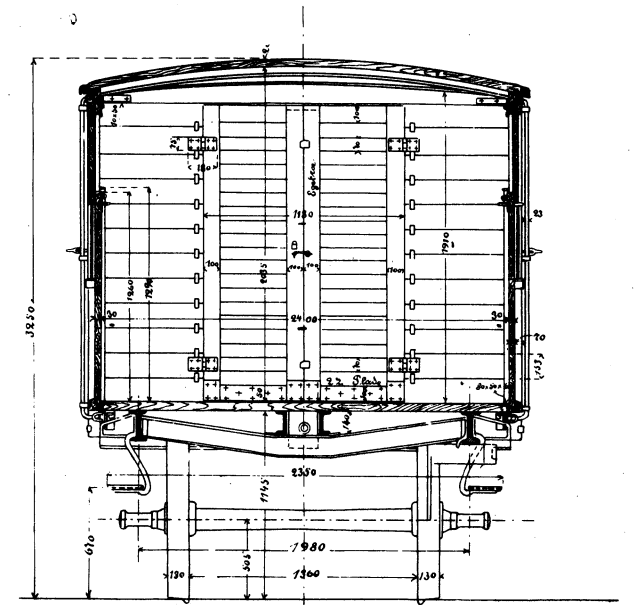
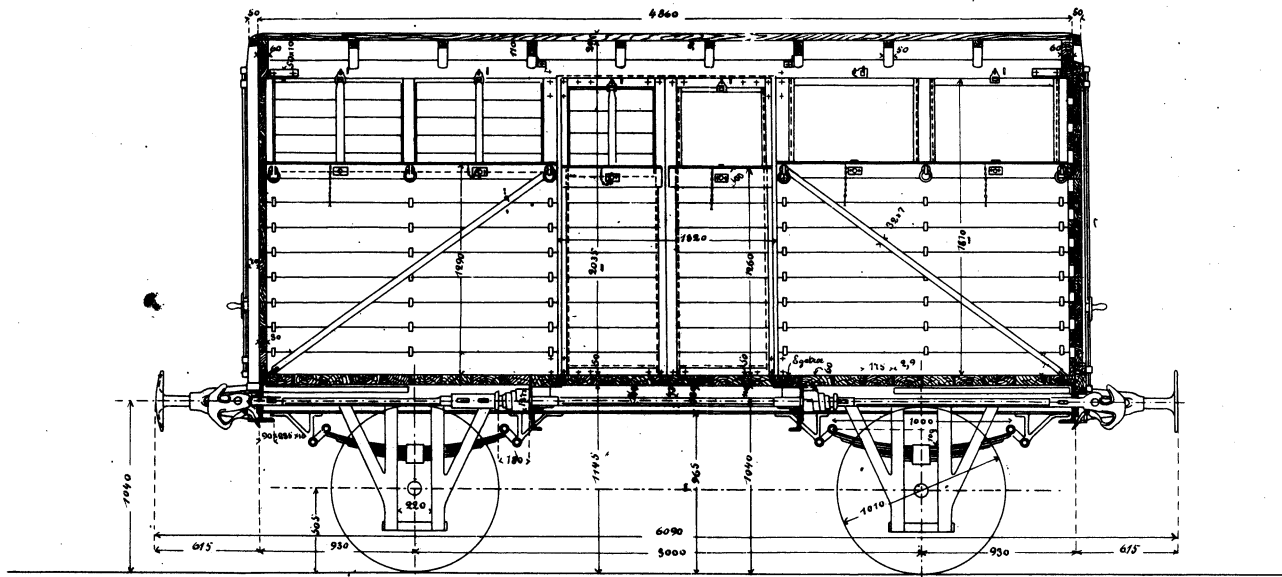

120 sand Skivelse.

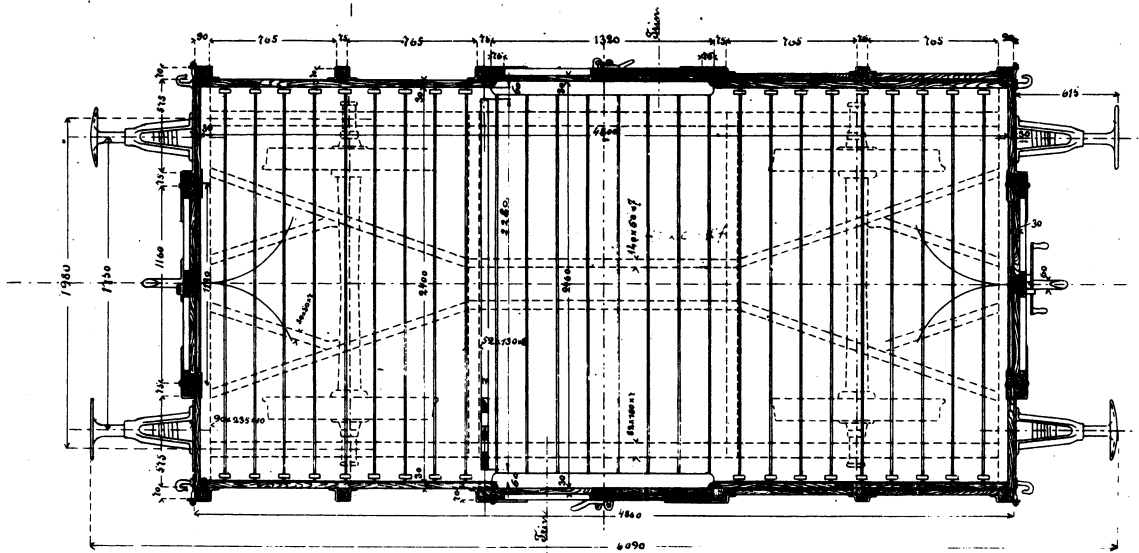

FFJ Q 229-233

262.6751.

Scandia i Danmark.

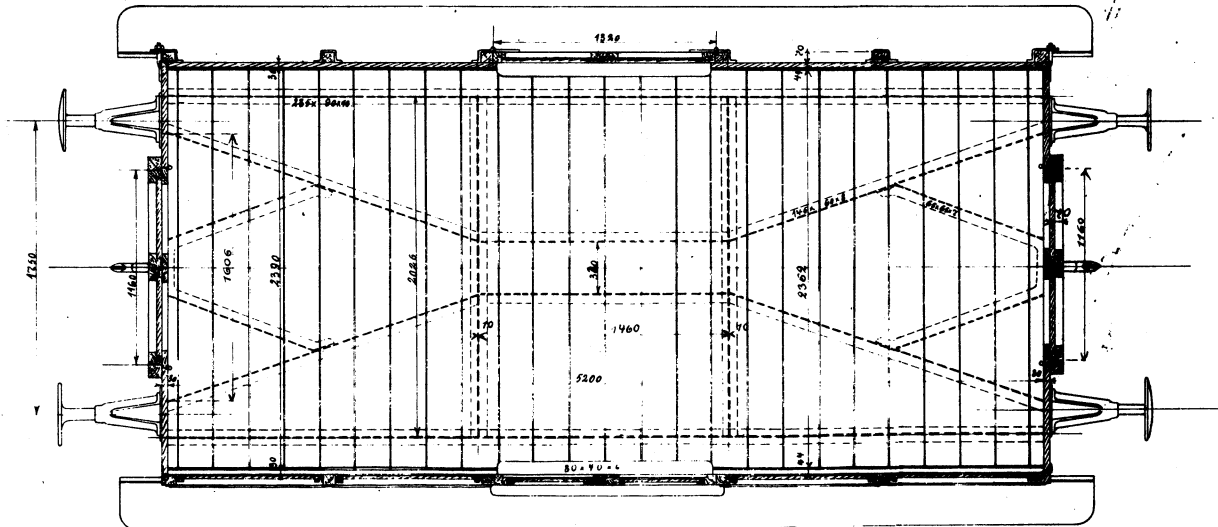
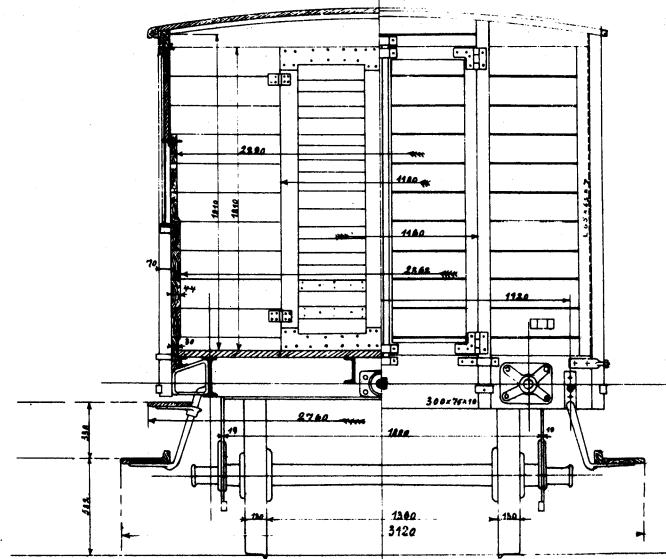
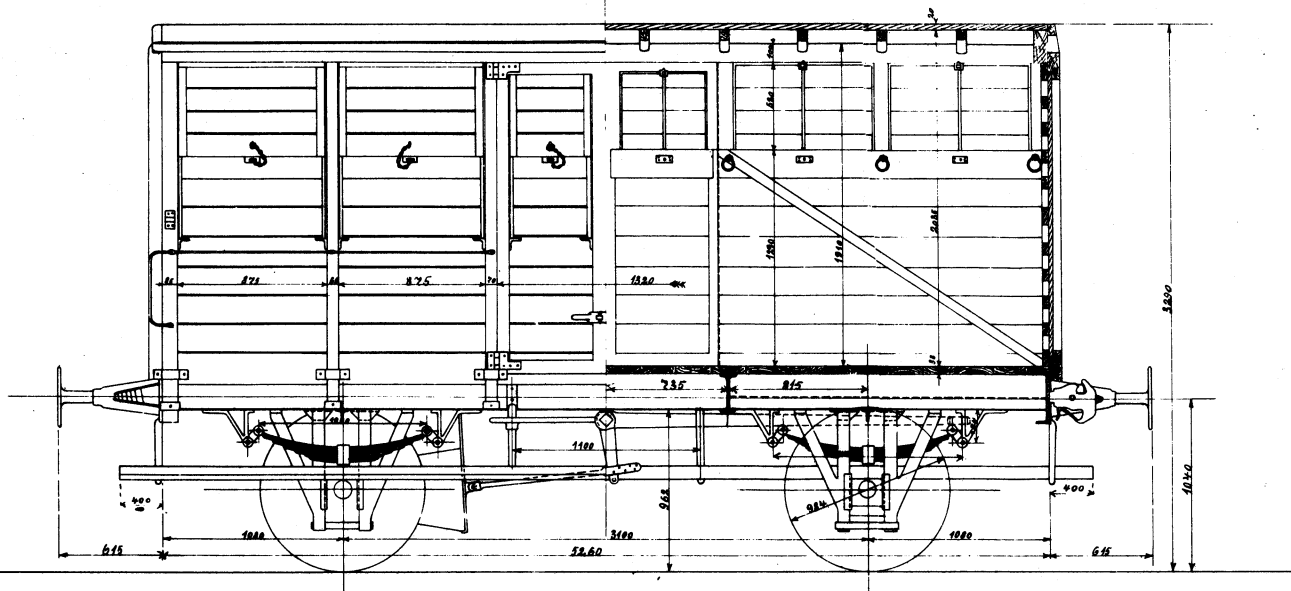

Lukket Sædeogn.
til
Calthorpe-Sædeogn-Si

FFJ Q 234-248
AHJ Q 4334-4337

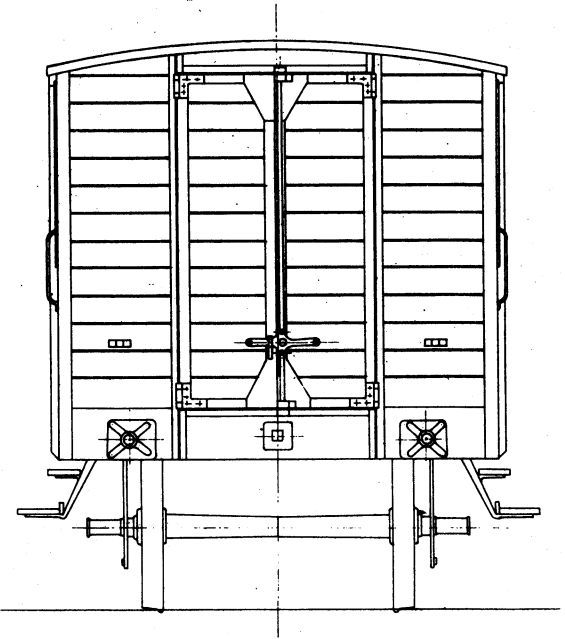
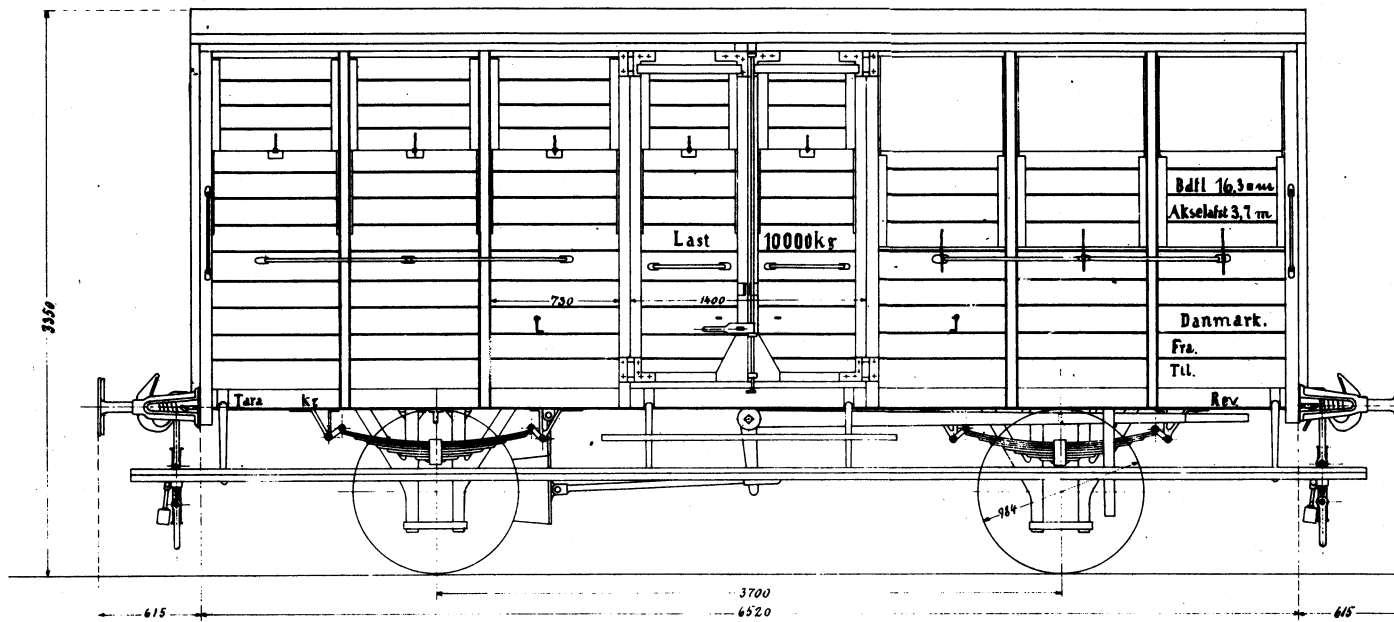

Nordjyllands forenede Privatbaner.

Lukket Godsvogn

Litra Q.

1/20 sand Str.

København Oktober 05.

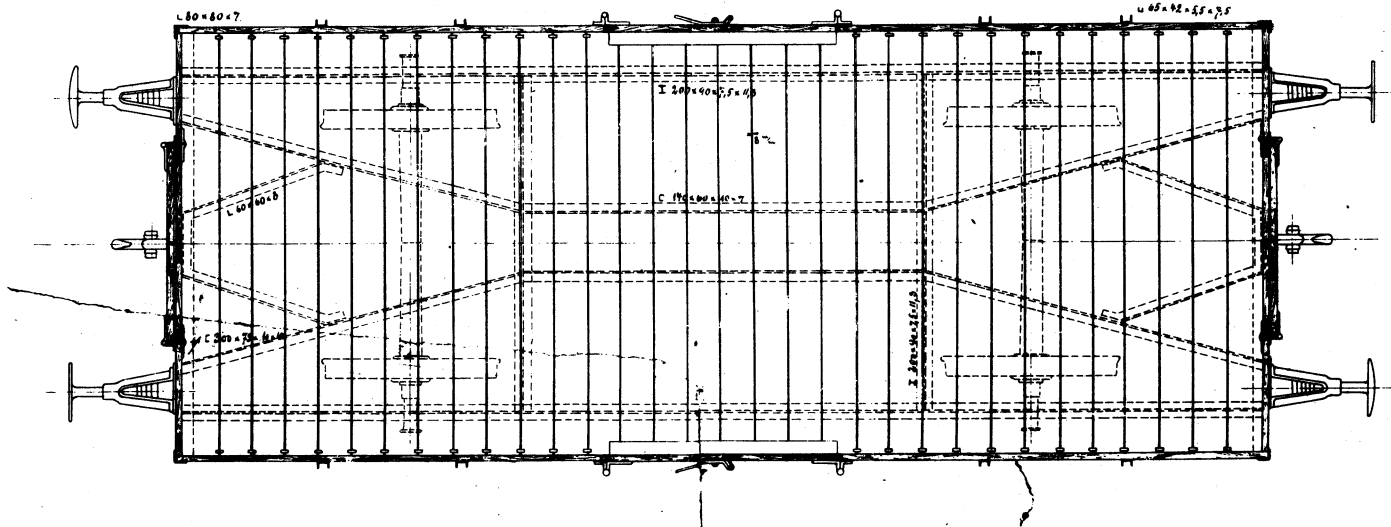

FFJ Qf 249-252

AHB Qf 2314-2315

AHJ Qf 4344-4345

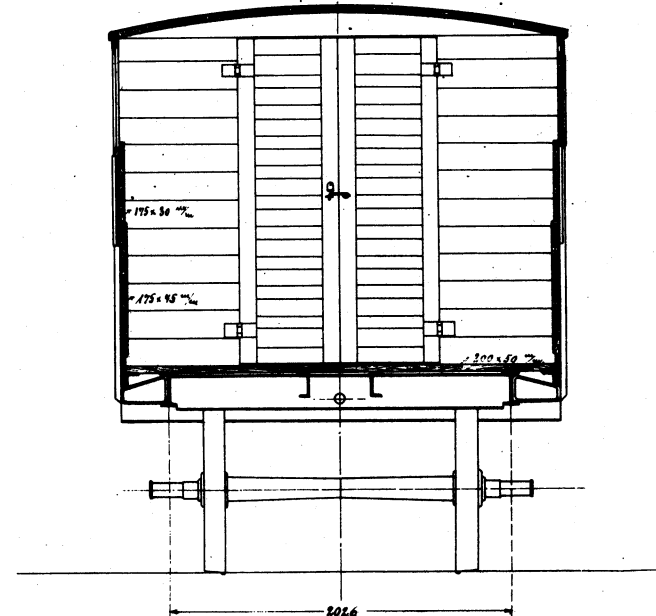
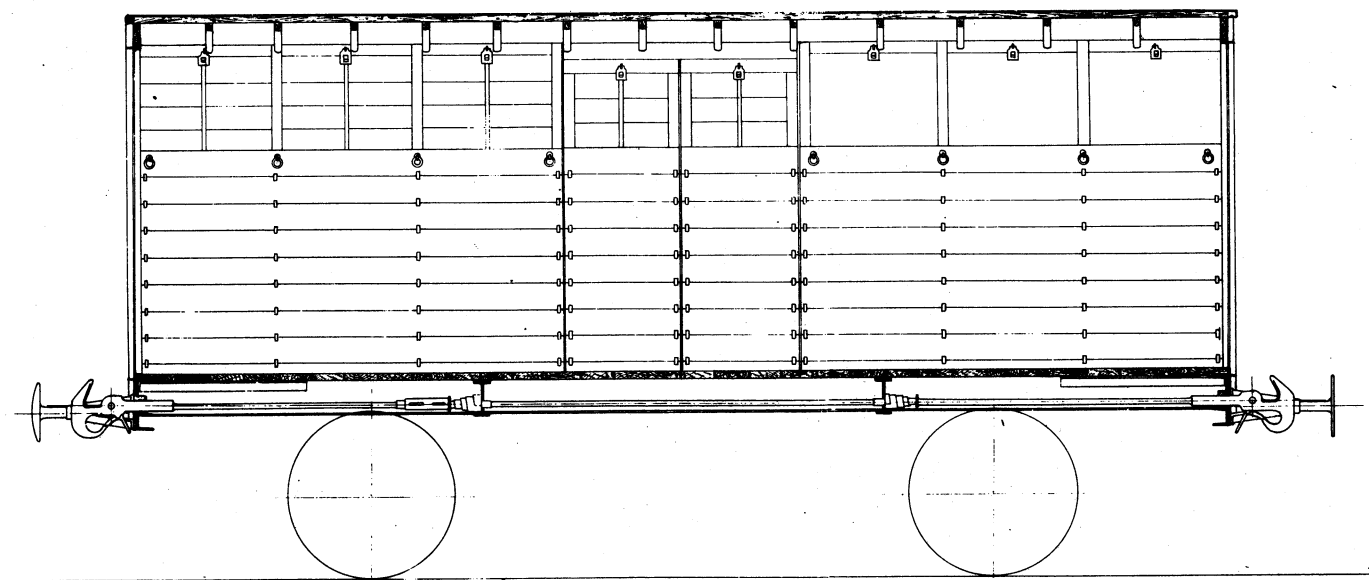

FFJ Qf 249-252
AHB Qf 2314-2315
AHJ Qf 4344-4345

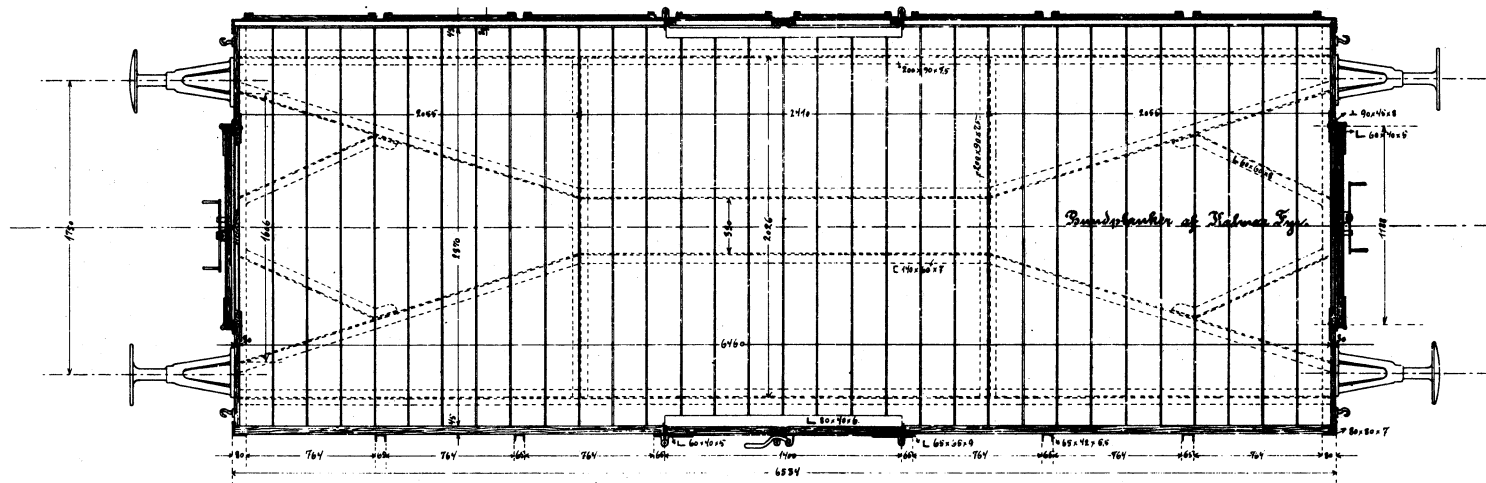
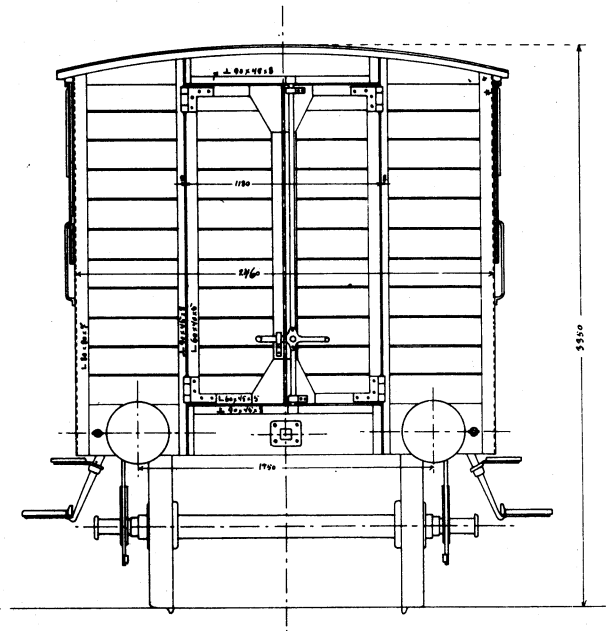
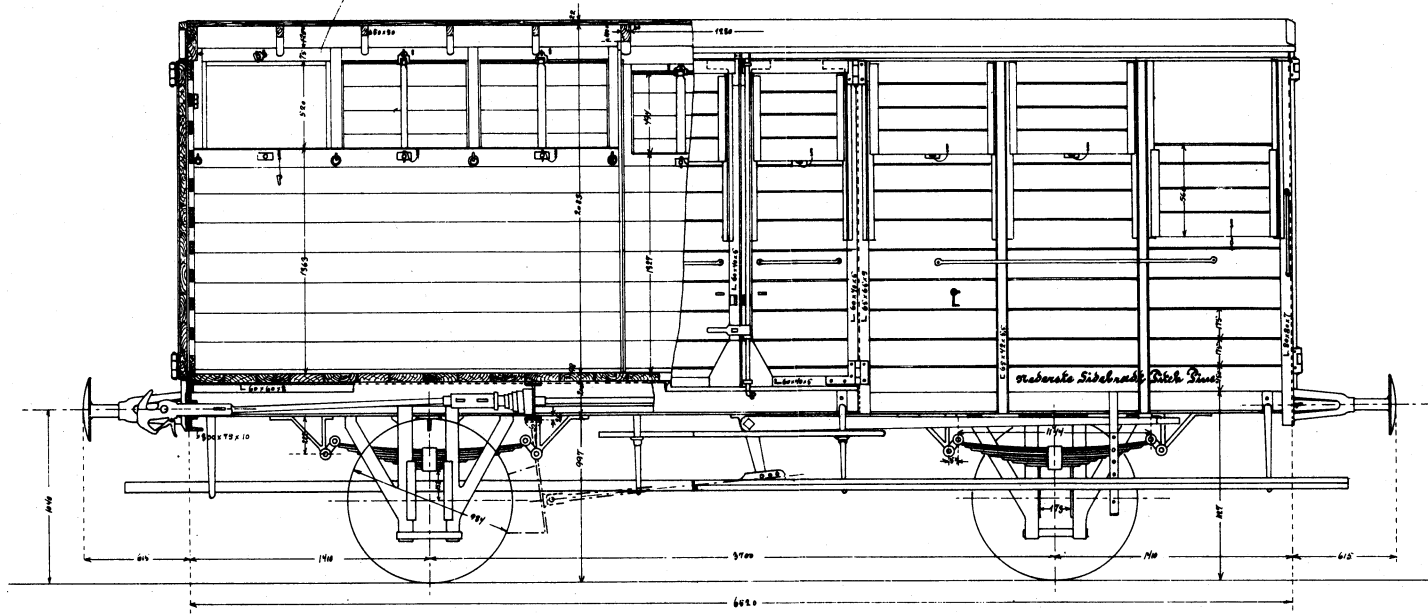

Lukket Godsvogn
til
Nordjyllands forenede Sivalbaner
Ordre 668.

FFJ Qb 253-258
AHB Qf 2316-17
AHJ Qf 4346-4347

264, 6030.

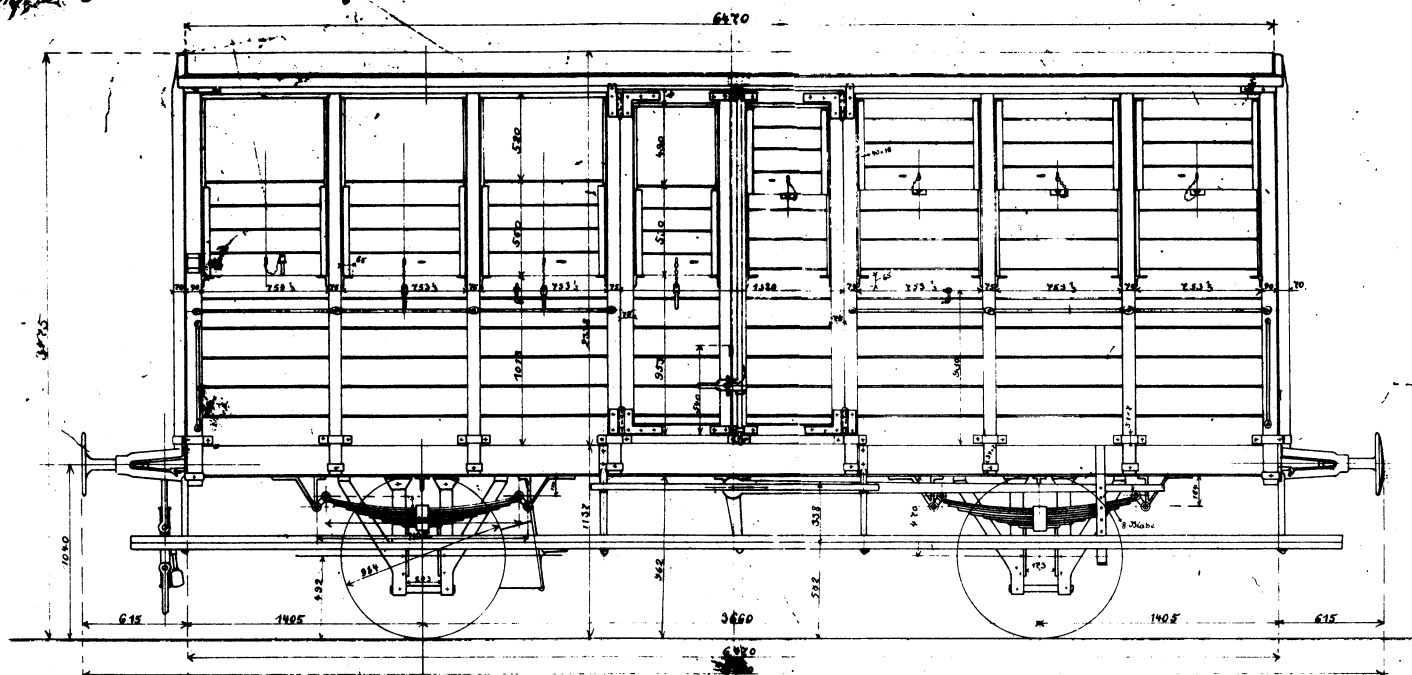

Scandia i Randers.

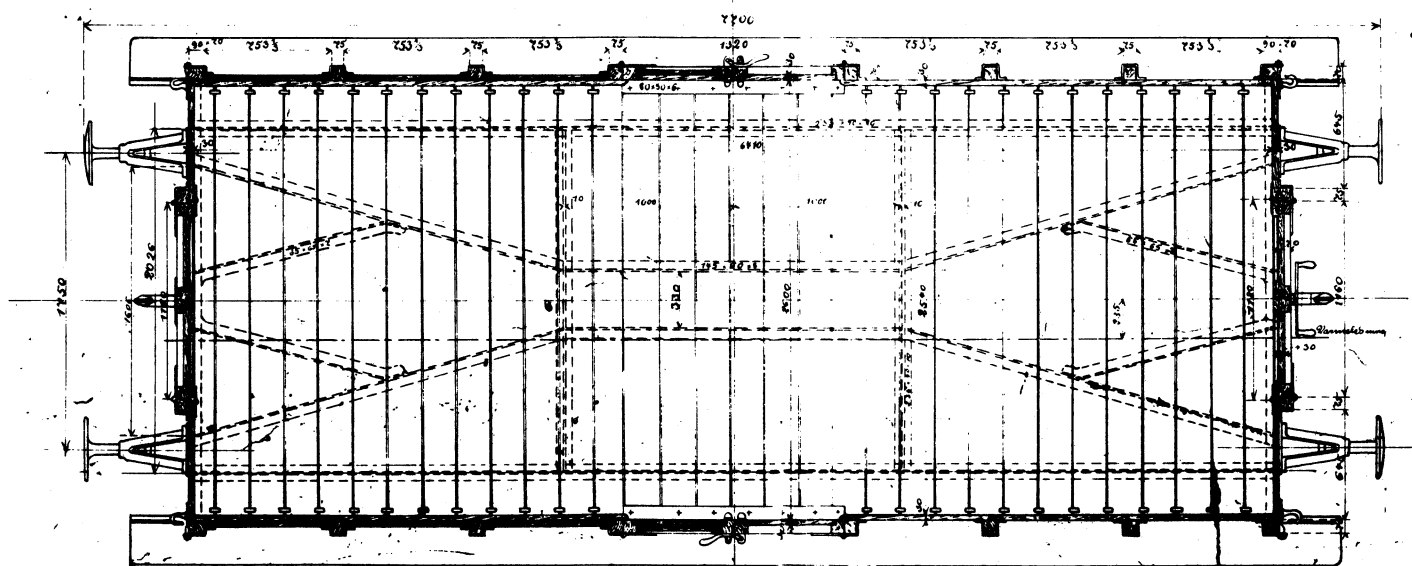
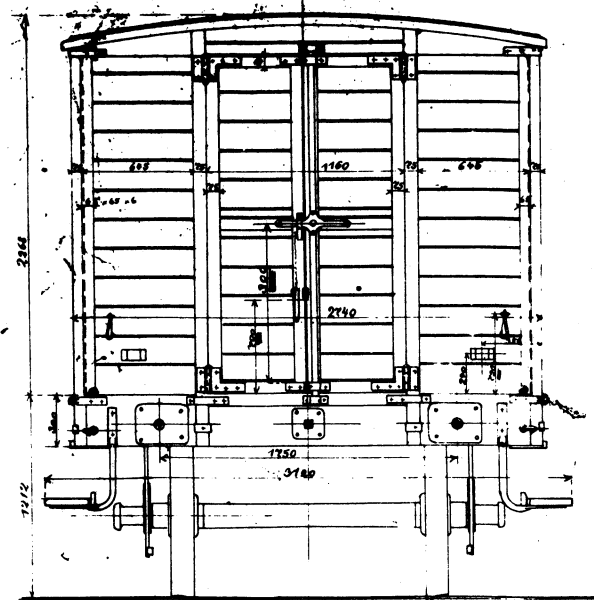

Lukket Godsvogn med Saandbremse

Scandia 1898
Hambro & Co.
1898
B. Hansen

FFJ Qf 259-331

AHB Qf 2318-2334

AHJ Qf 4348-4362

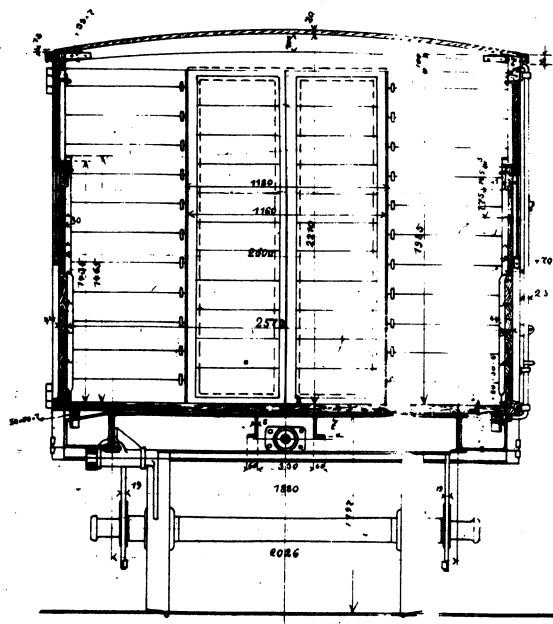
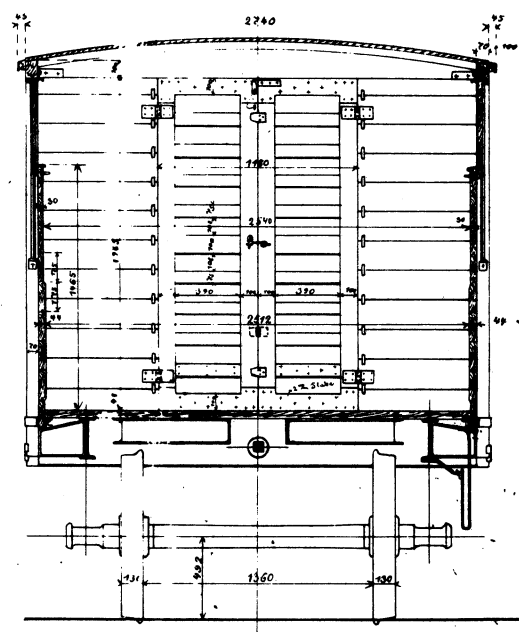
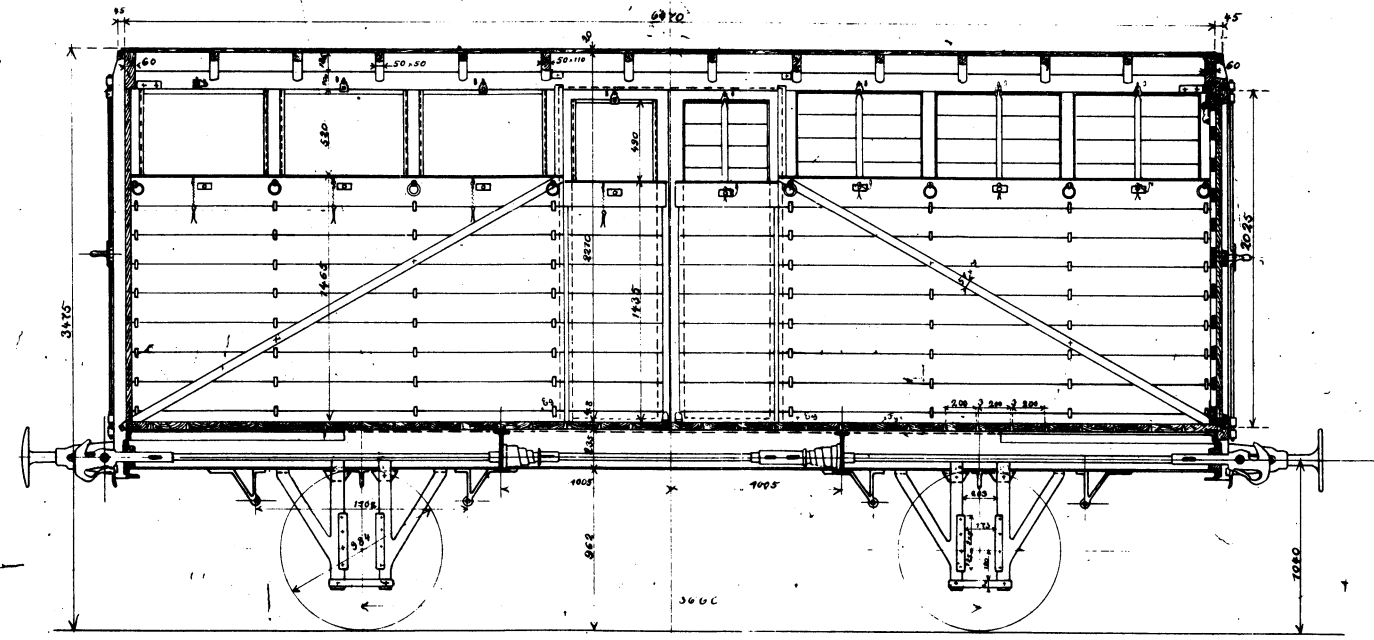

FFJ Qf 259-331
 AHB Qf 2318-2334
 AHJ Qf 4348-4362

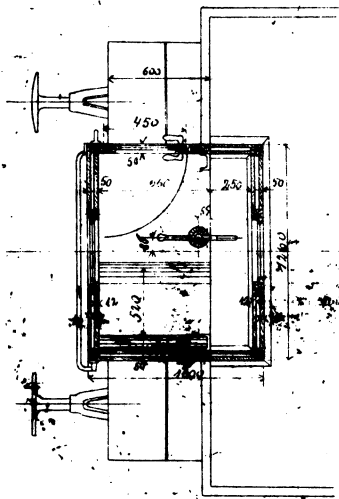
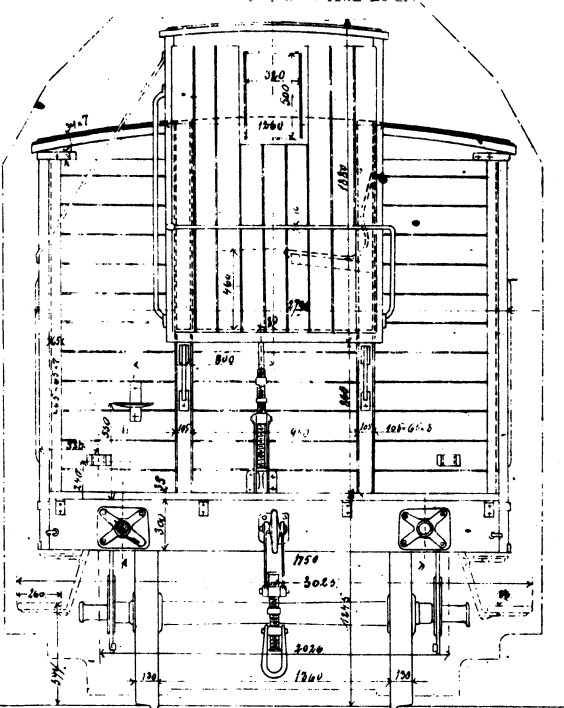
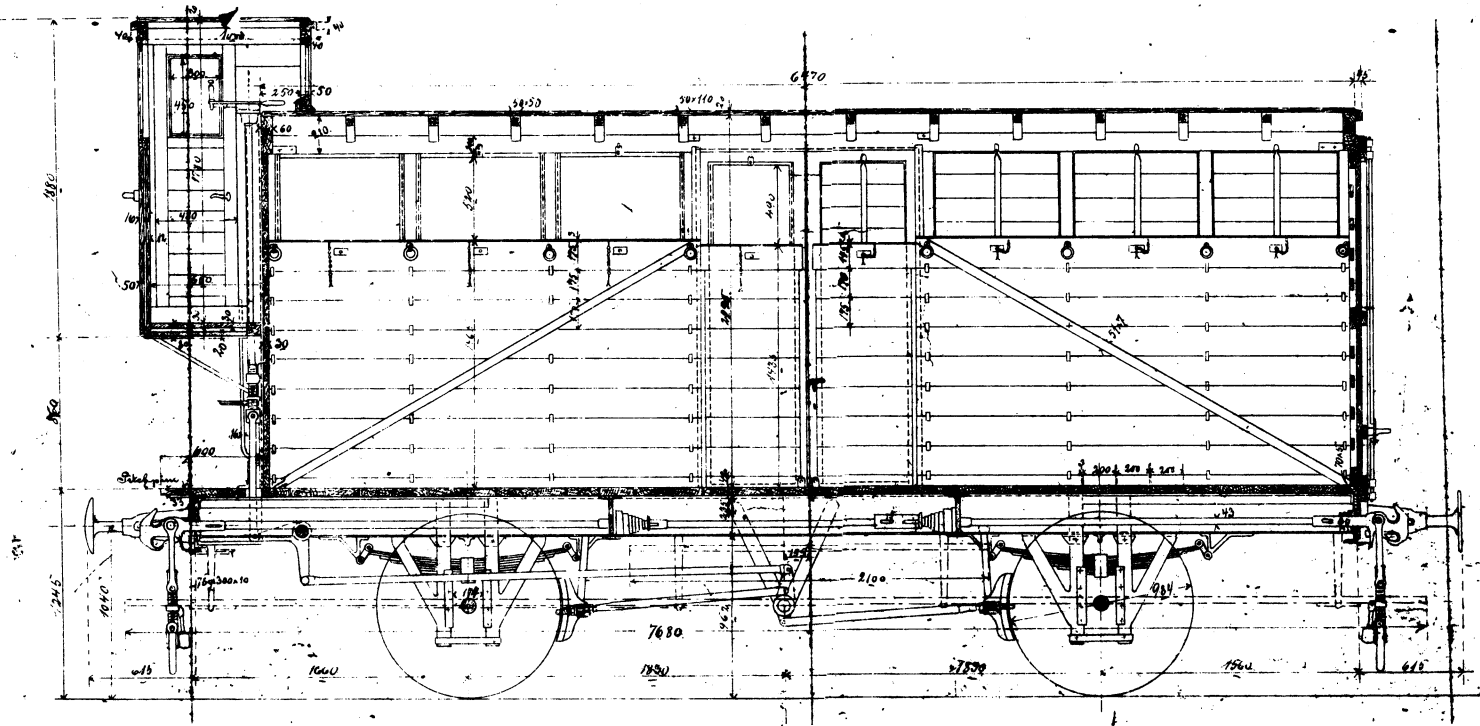
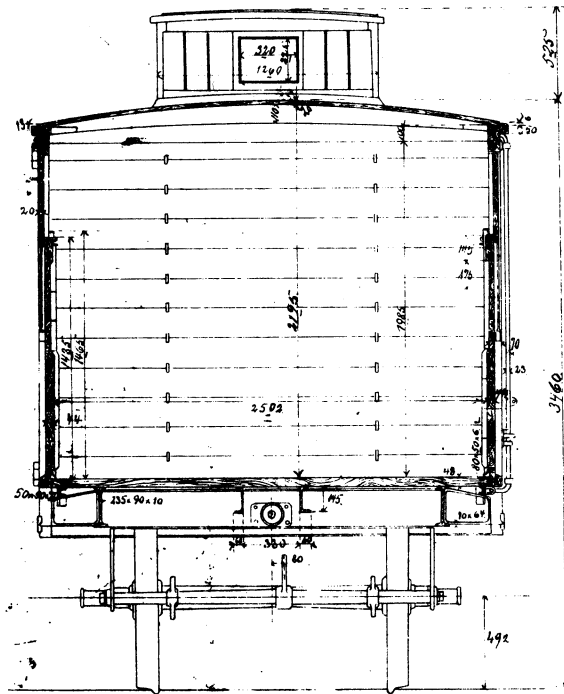

Tilbudstegning

AHB (Qf 2301-2303) med skrubremse
(Qf 2304-2309) med håndbremse

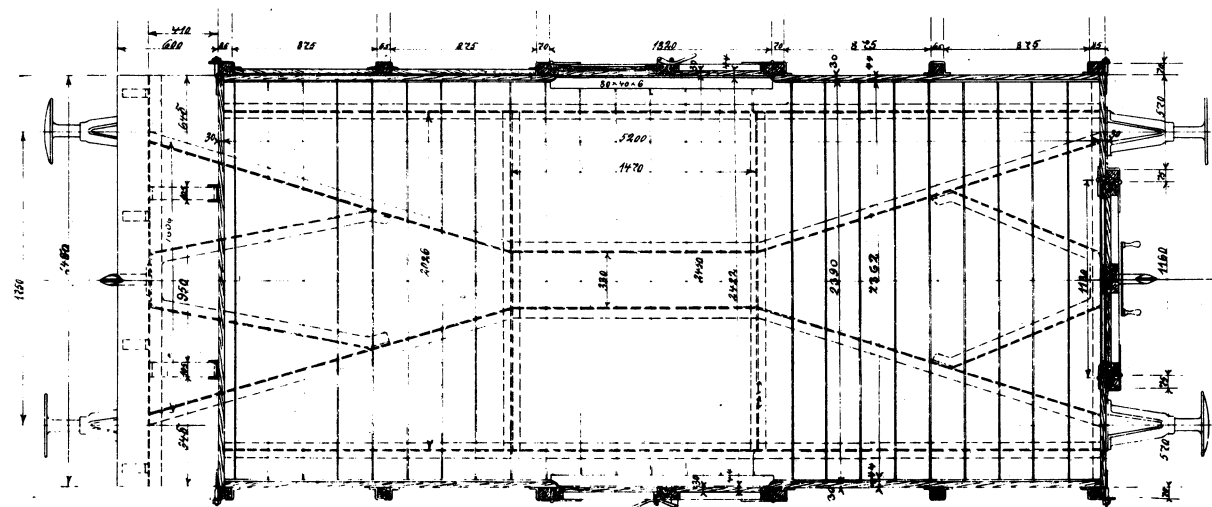
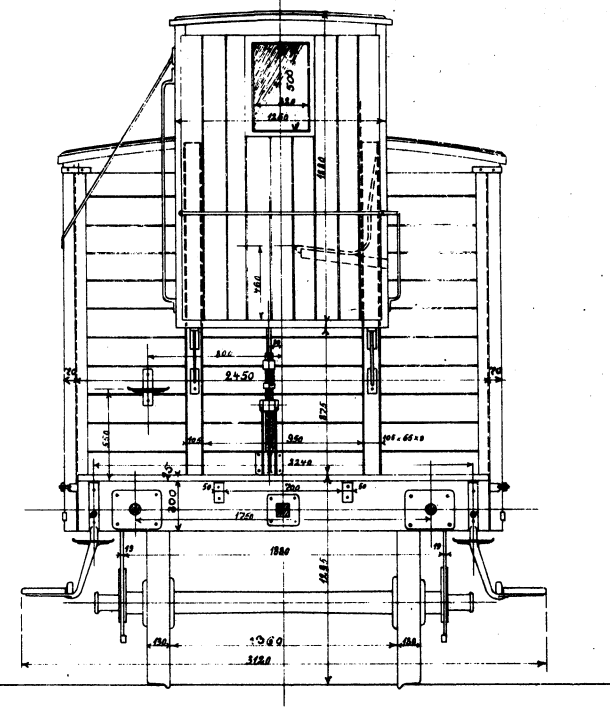
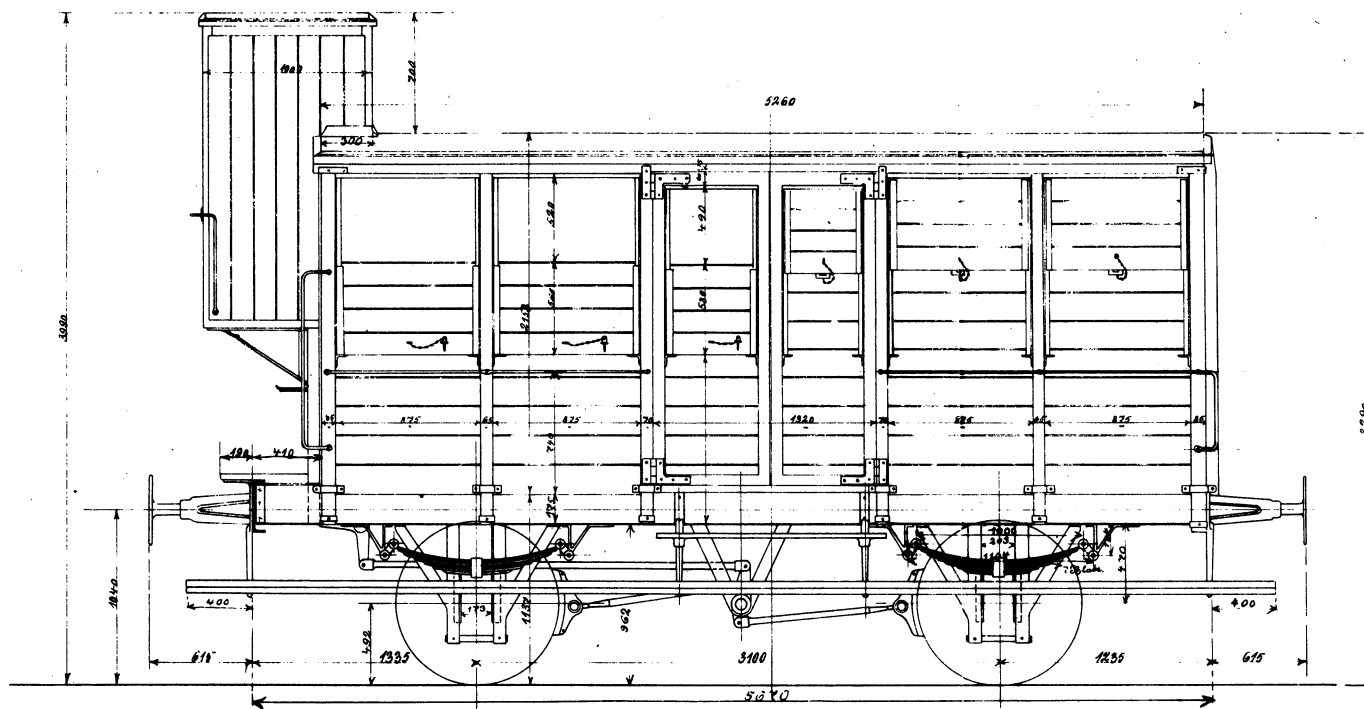

Lukket Gjærbogvagn med Fkrisibremser
til
Stokholms-Bohuslän-Banen.

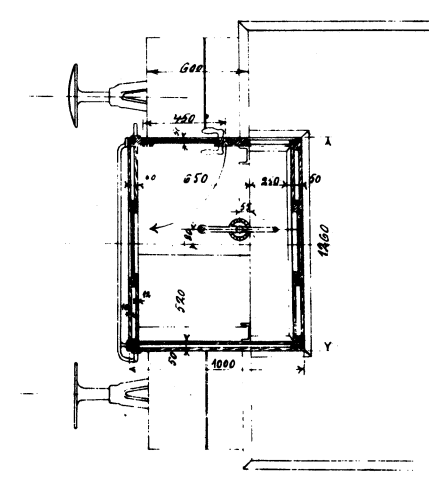
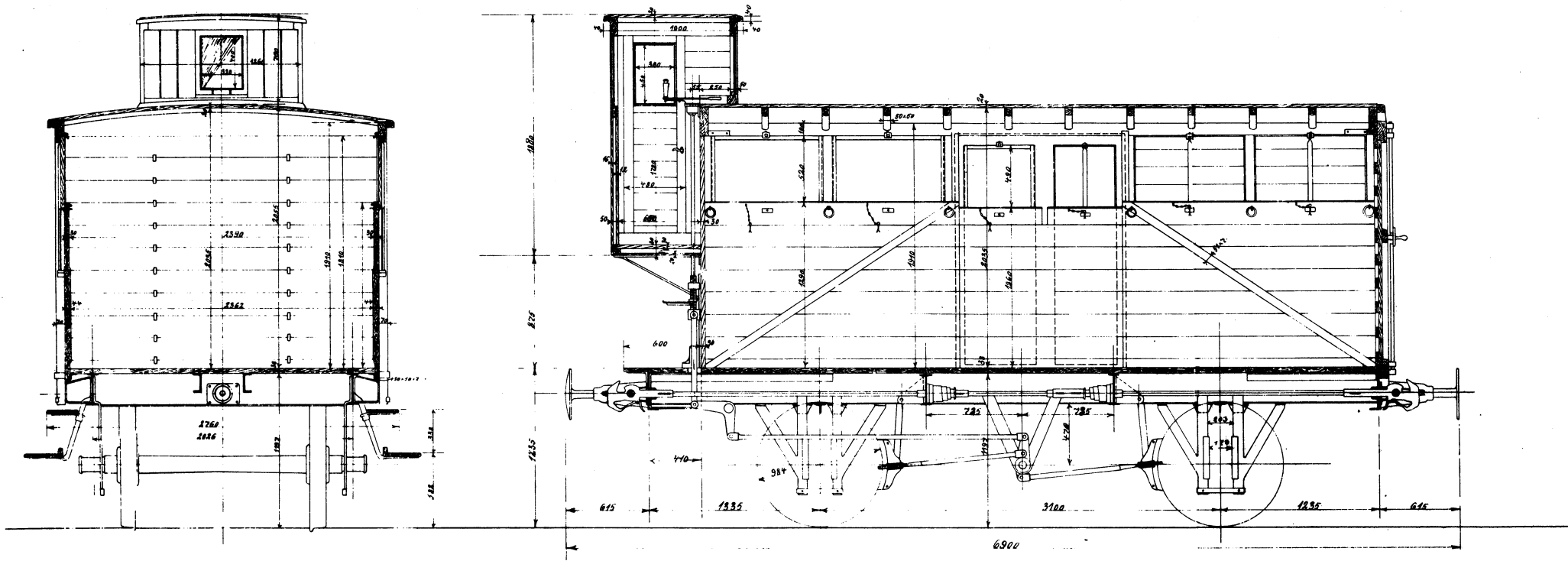

AHJ Q 4331-4333

Nr 6485.

Scandia Randers.

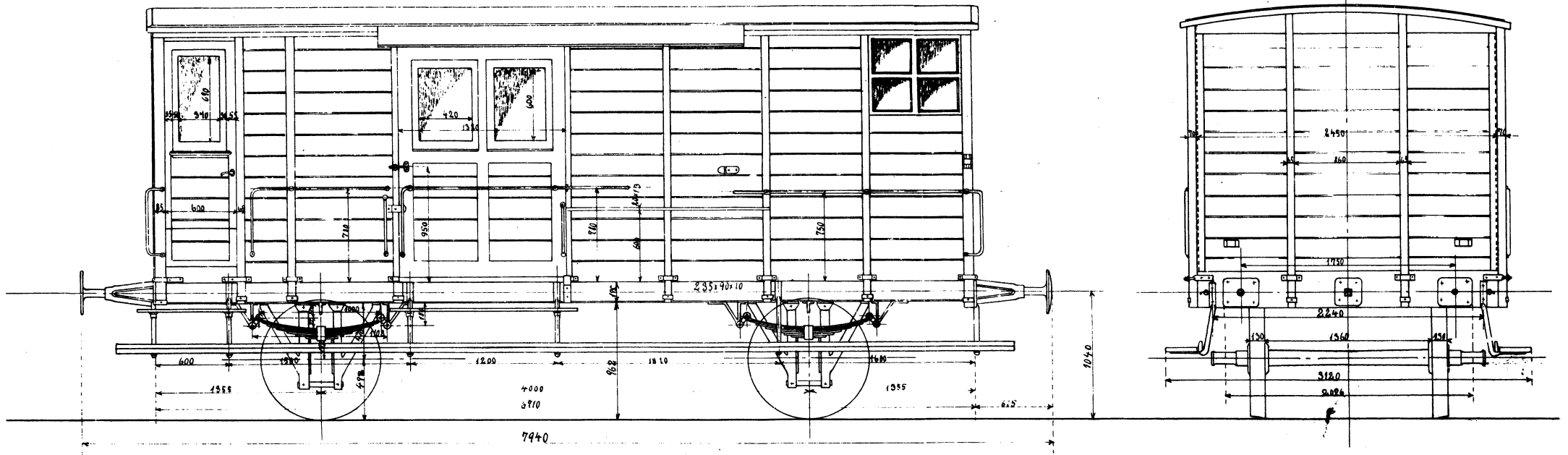

Lokvoagn til Hovedsundby - Søby - Banen.

Scandia 1898.

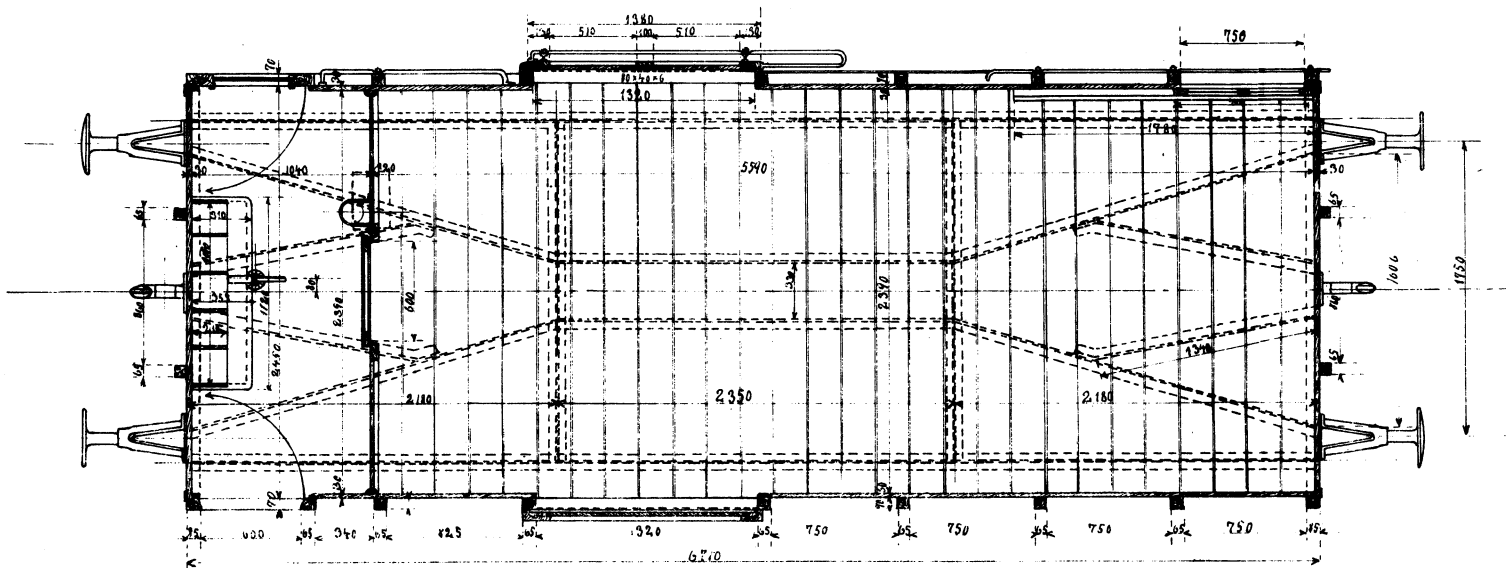

Scandia 60-111
J.F.

FFJ Qs 441-446

516777.

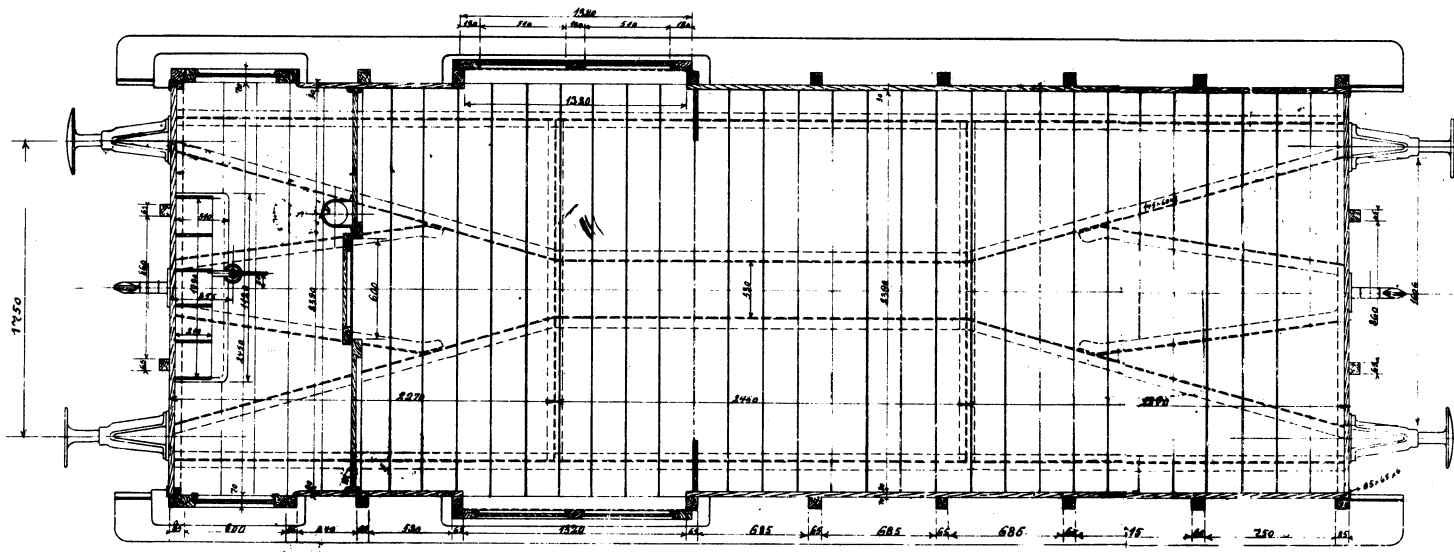
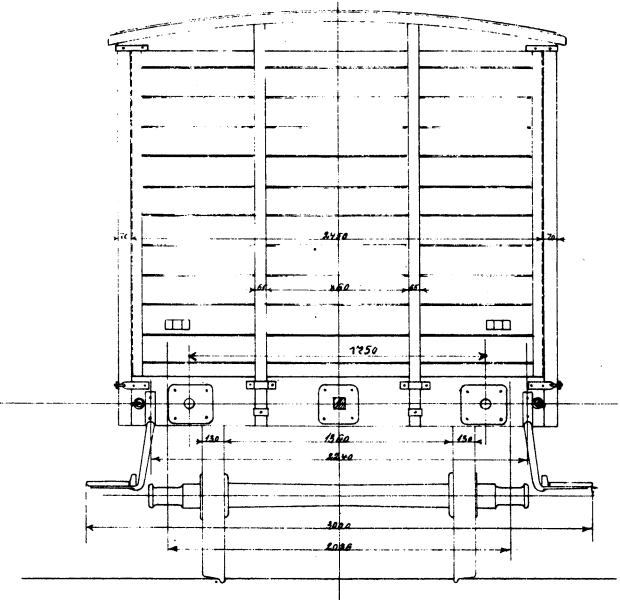
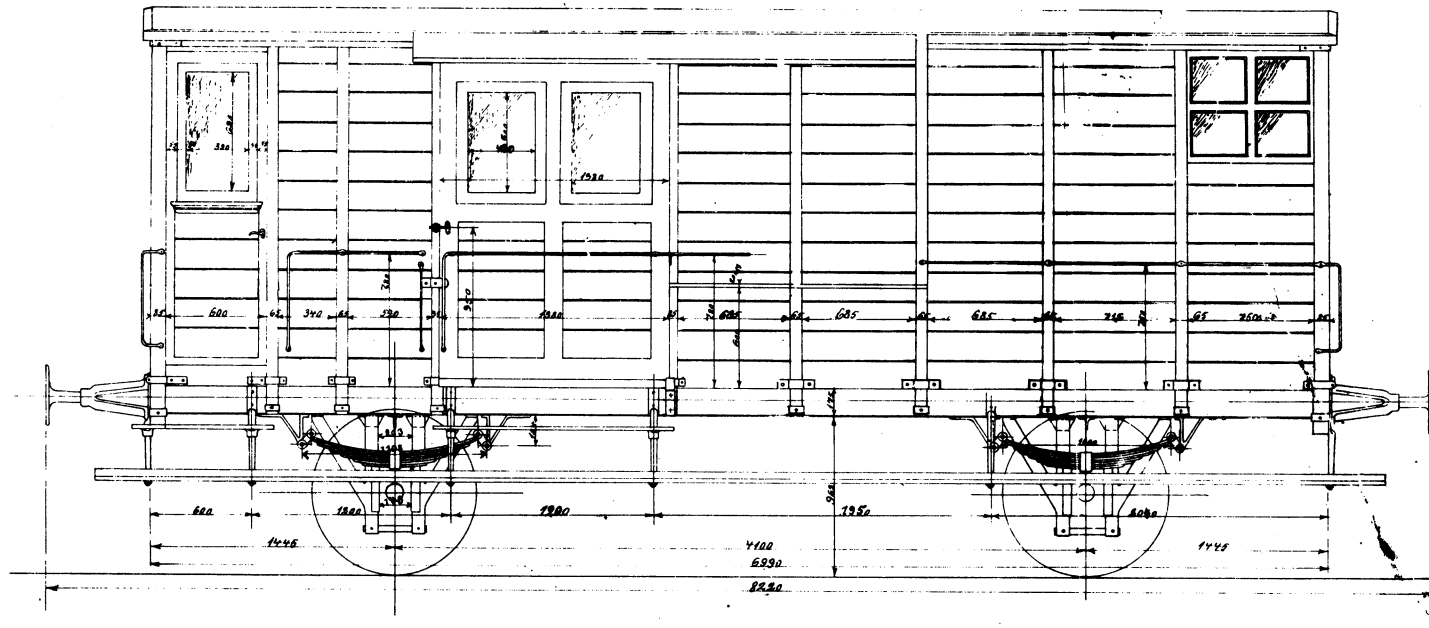

*Dakvogn.
til
Ålborg = Esbjerg = Banen.*

AHJ Qs 4461-4465

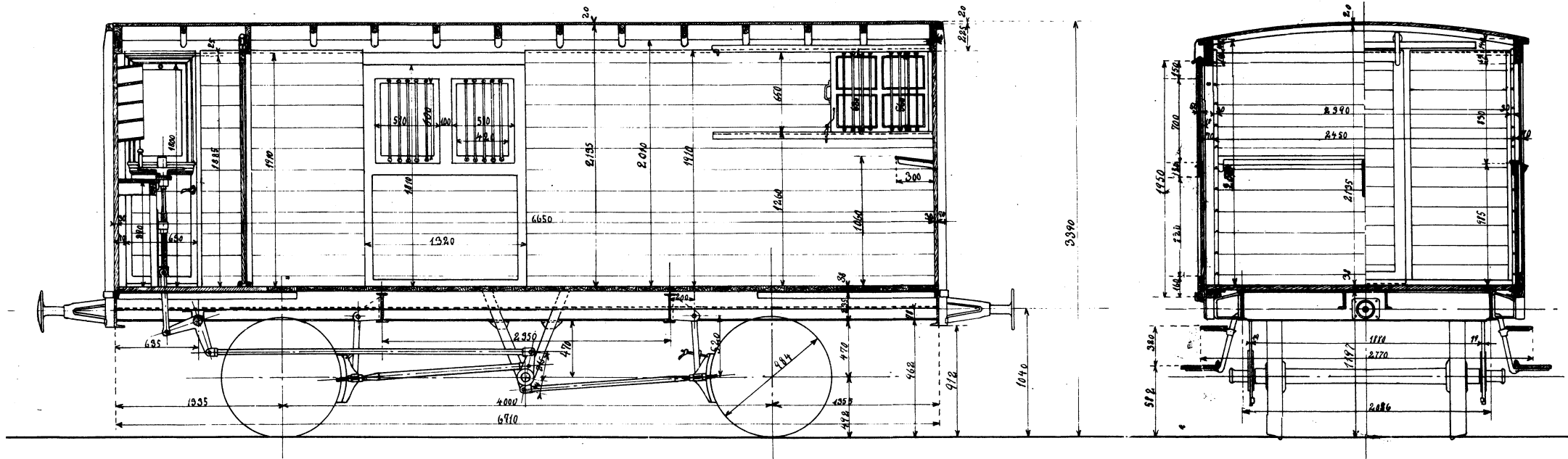

FFJ Qs 441-446

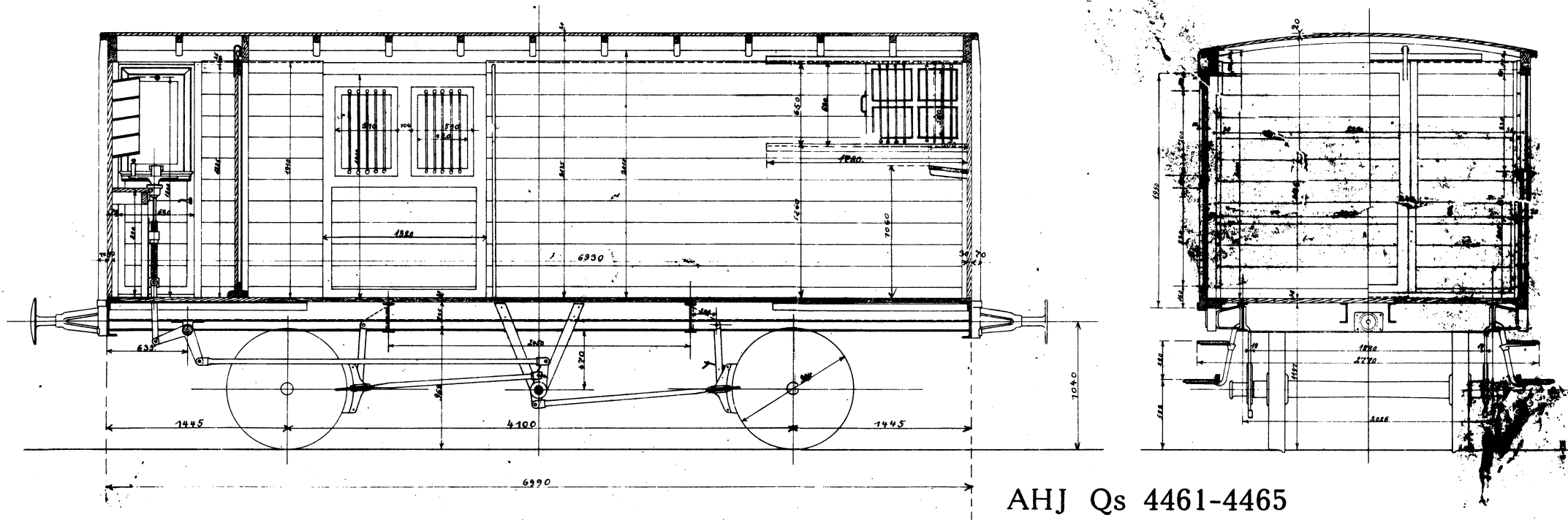

AHJ Qs 4461-4465

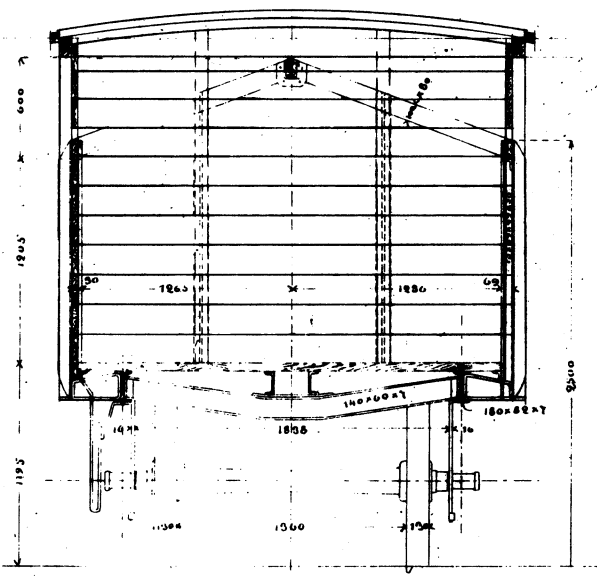
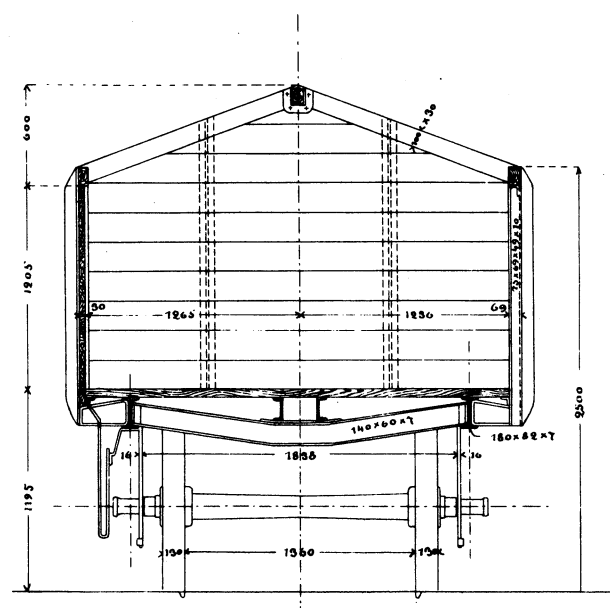
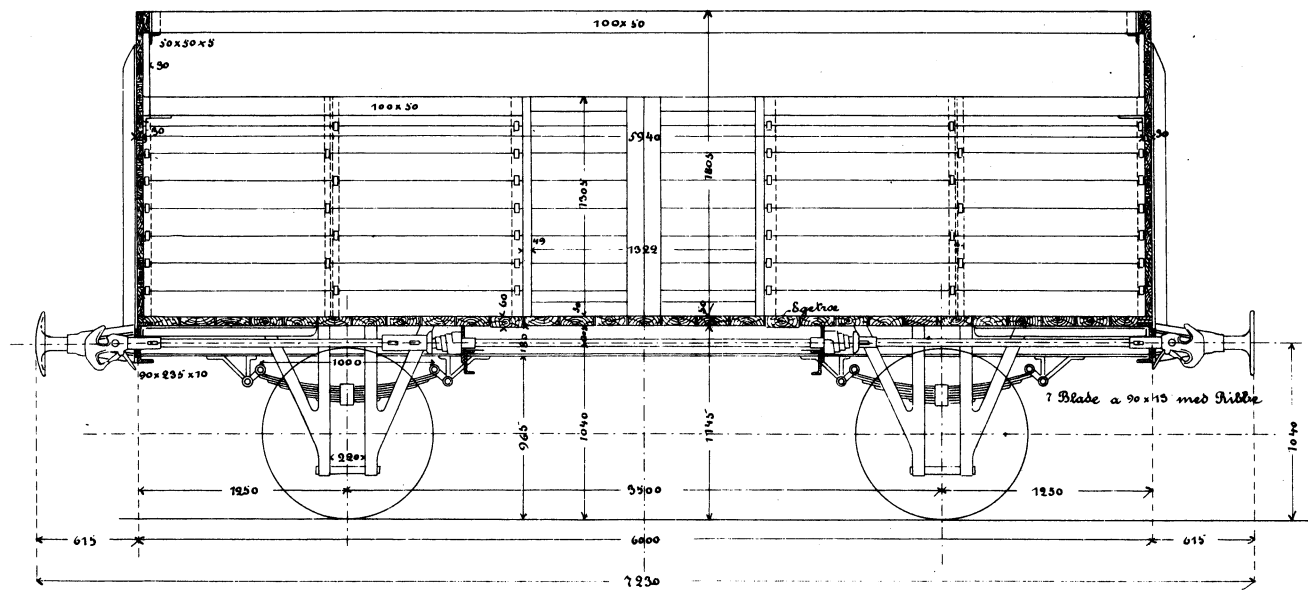

FFJ Ka 501-504
 AHB K 2531-2532

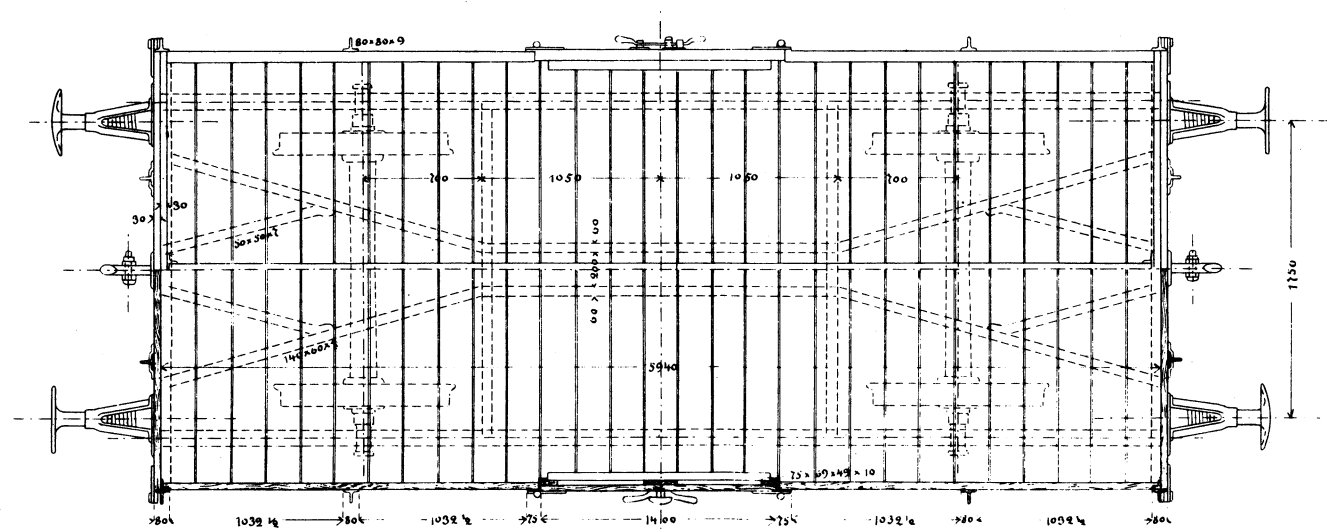
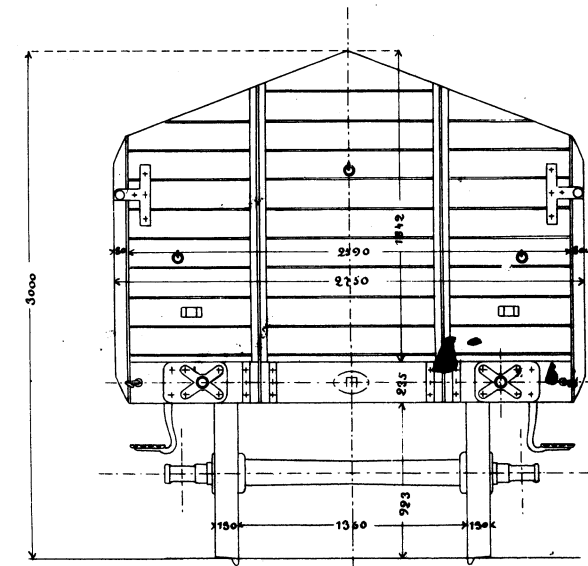
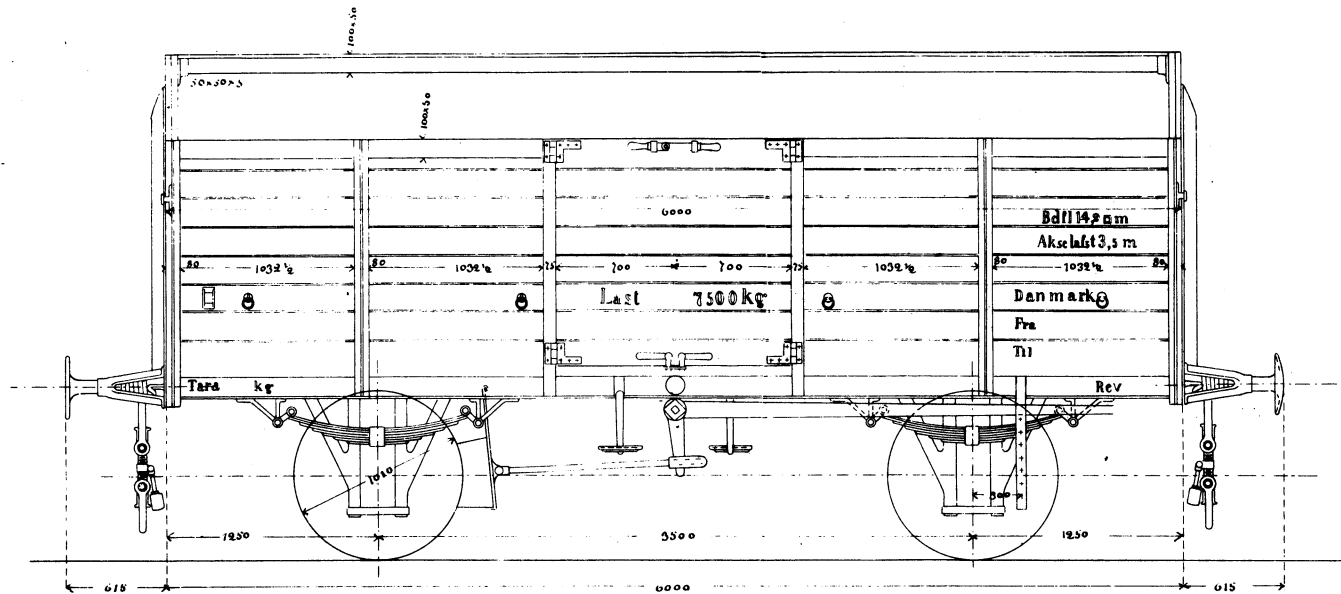

Aaben højsjælet Godsvoan.

med Haandbremse

Bæreevne 150 Ckm: Bunnflade 14,90 m

Skaribo den 24 1896.

FFJ Ka 501-504

AHB K 2531-2532

194.^B

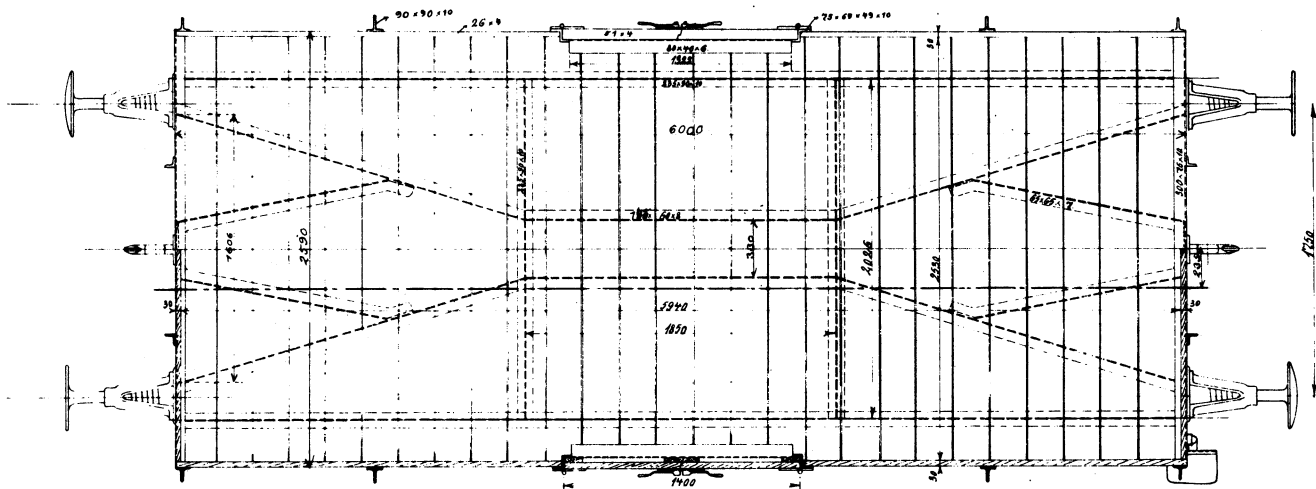
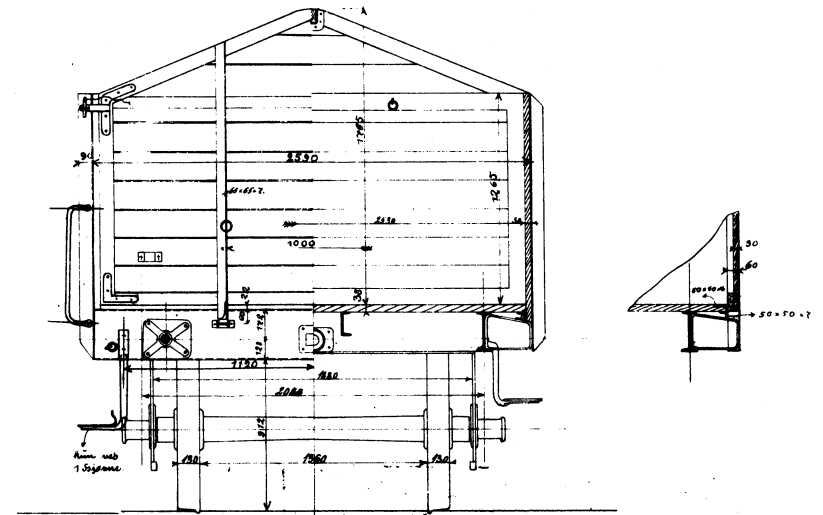
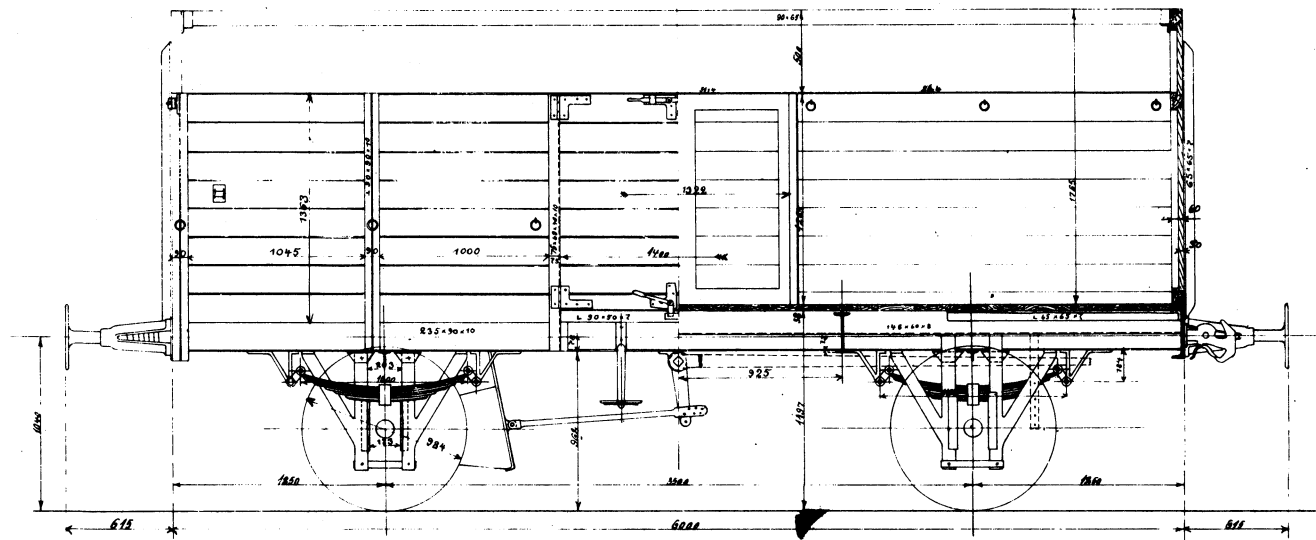

*Købt af Kjøbsbeholdningen
til
Ralborg - Fabrikant*

*Scandia 1897
Hvornæsthusen.*

FFJ K 505-512
AHB K 2533-2534
AHJ K 4541-4544

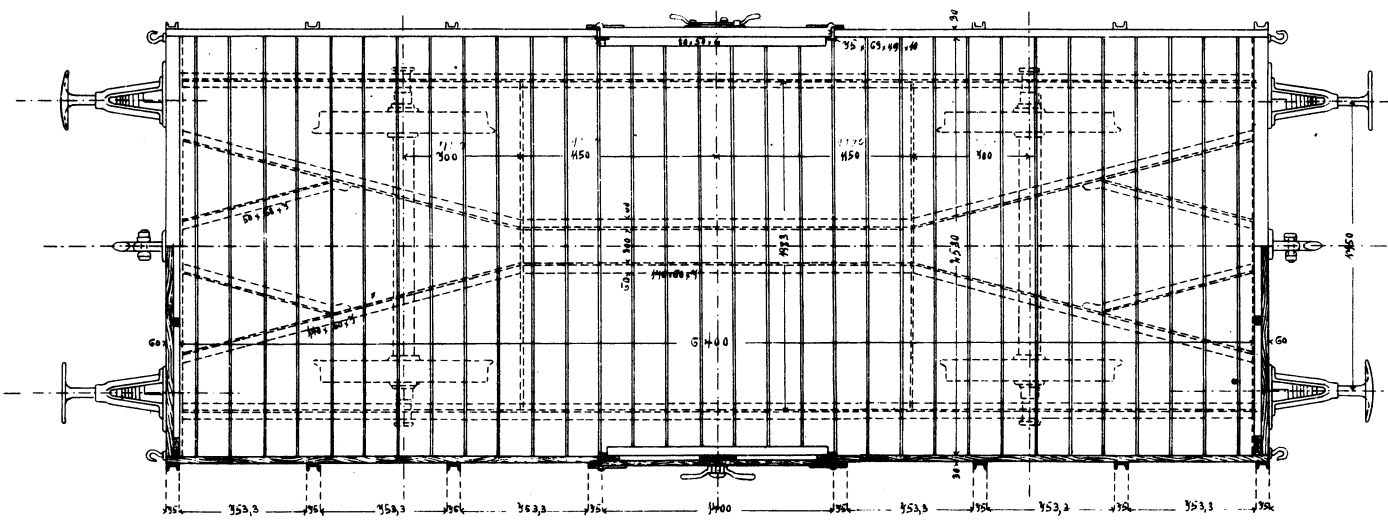
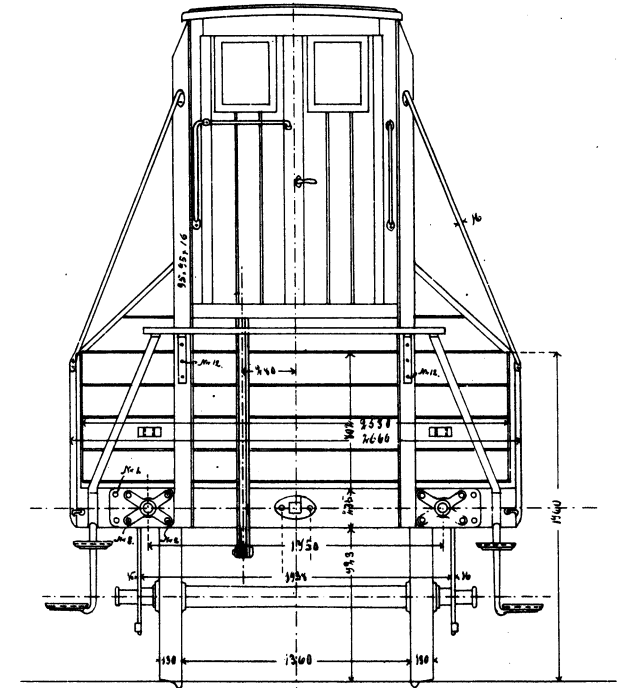
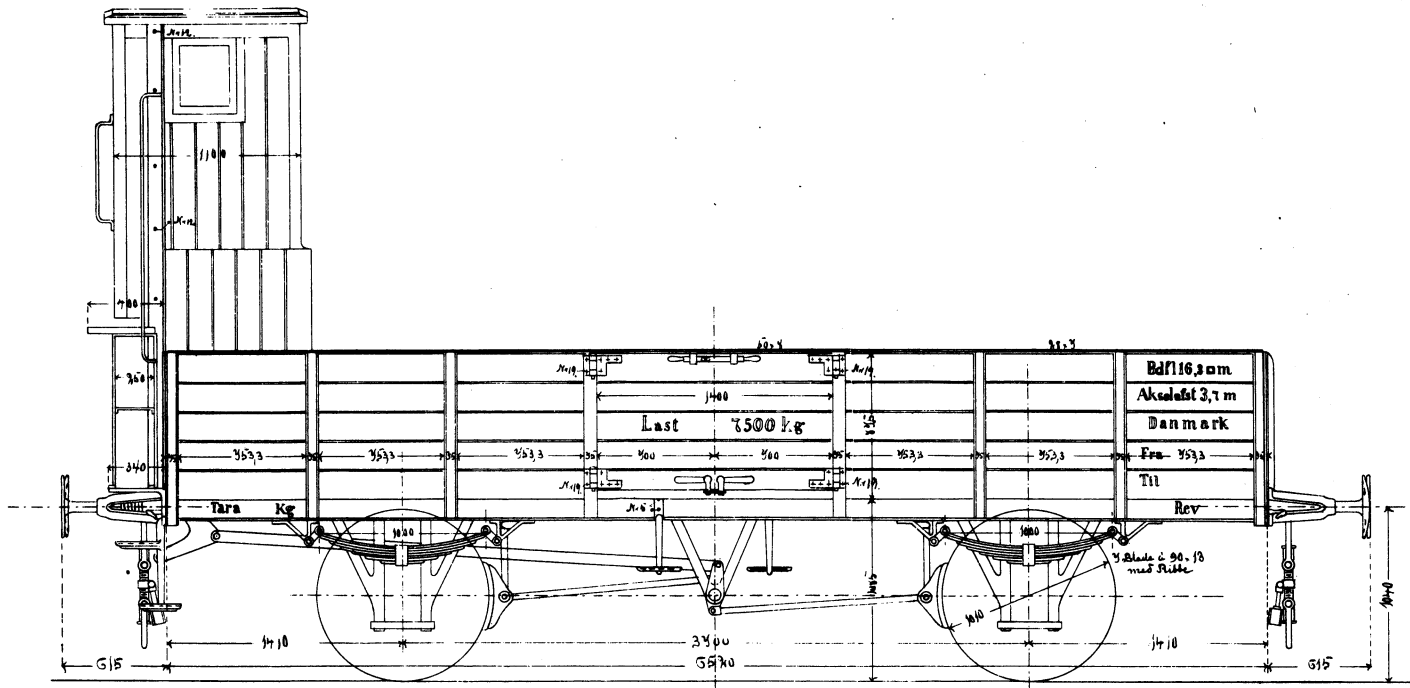

123.a

FFJ Pa 601-602

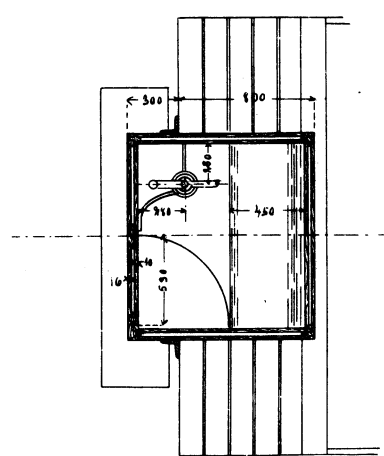
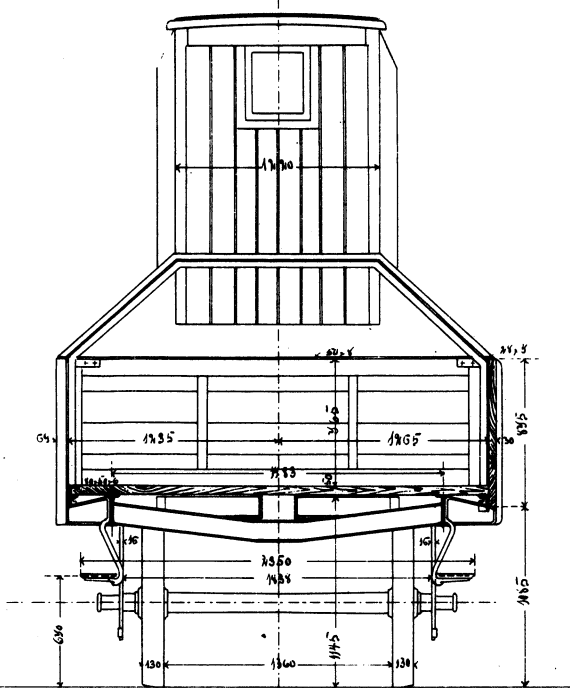
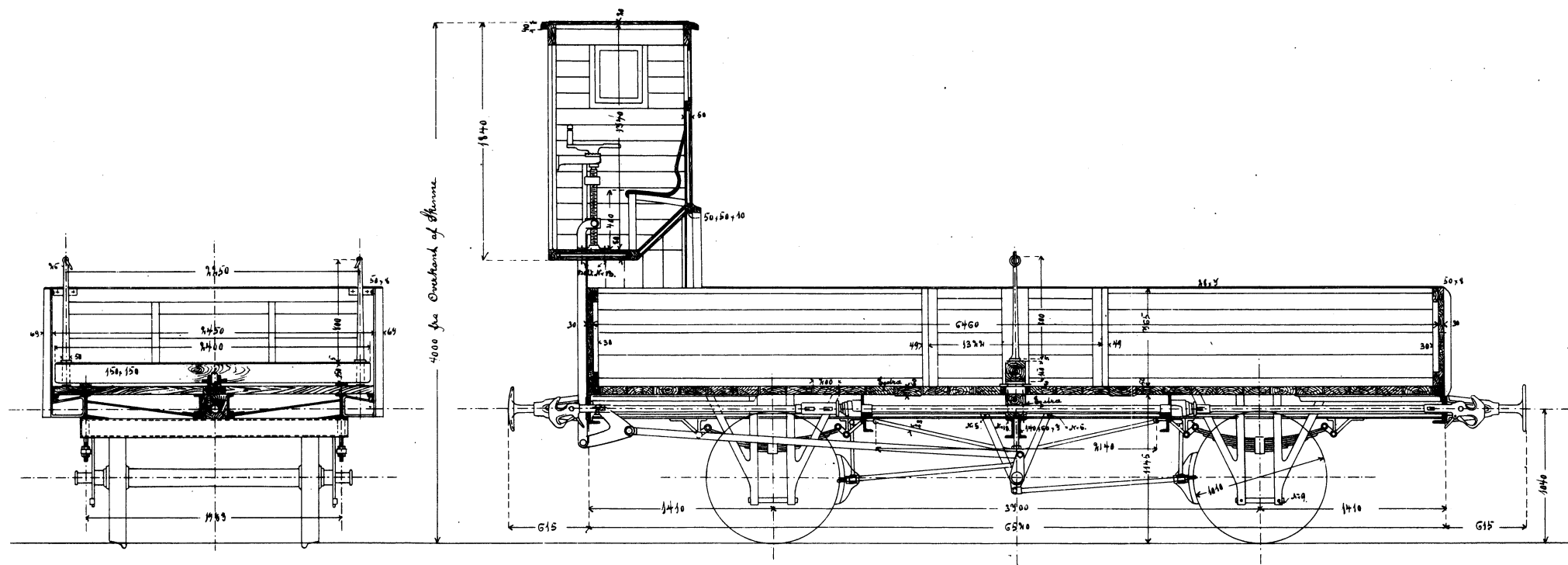

*Osben Godsvoeri
med Skruetremse.
Bæreevne 150 Ctn: Bundflade 16,30^m
Marts d 27 1896.*

FFJ Pa 601-602

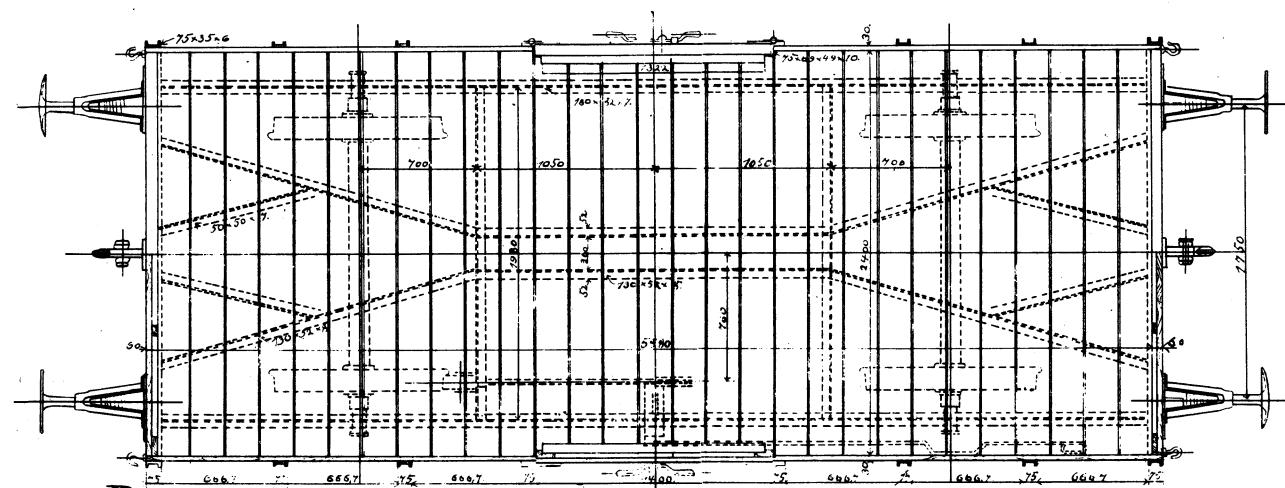
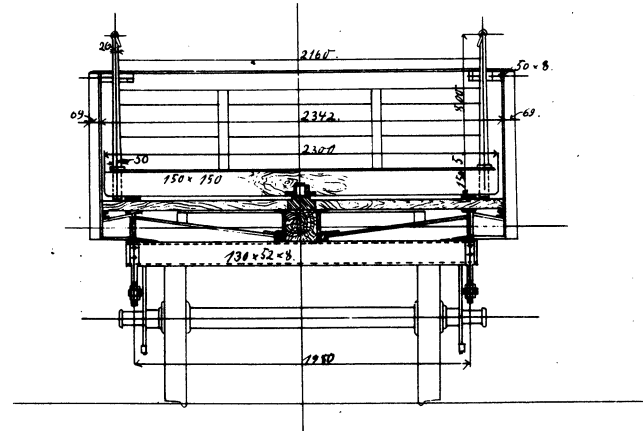
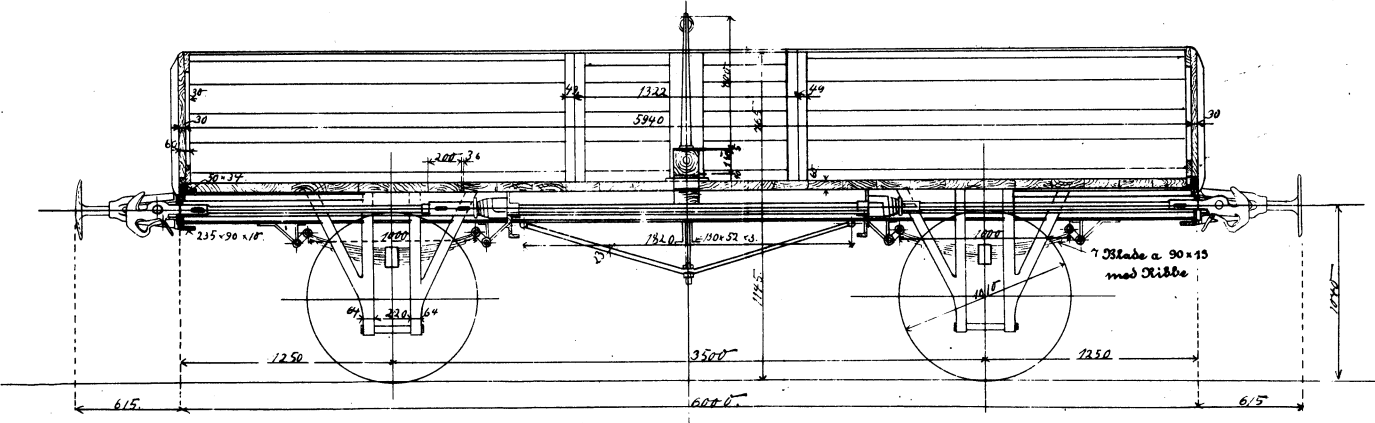
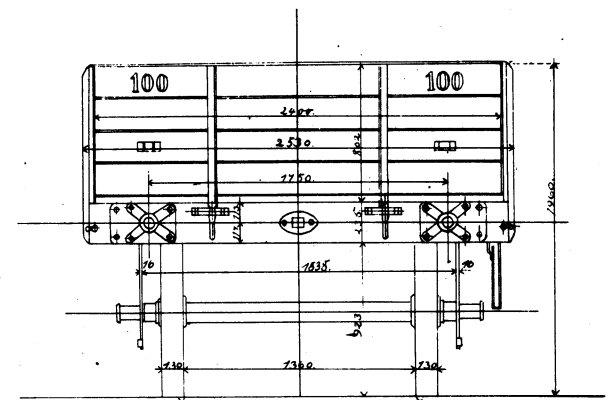
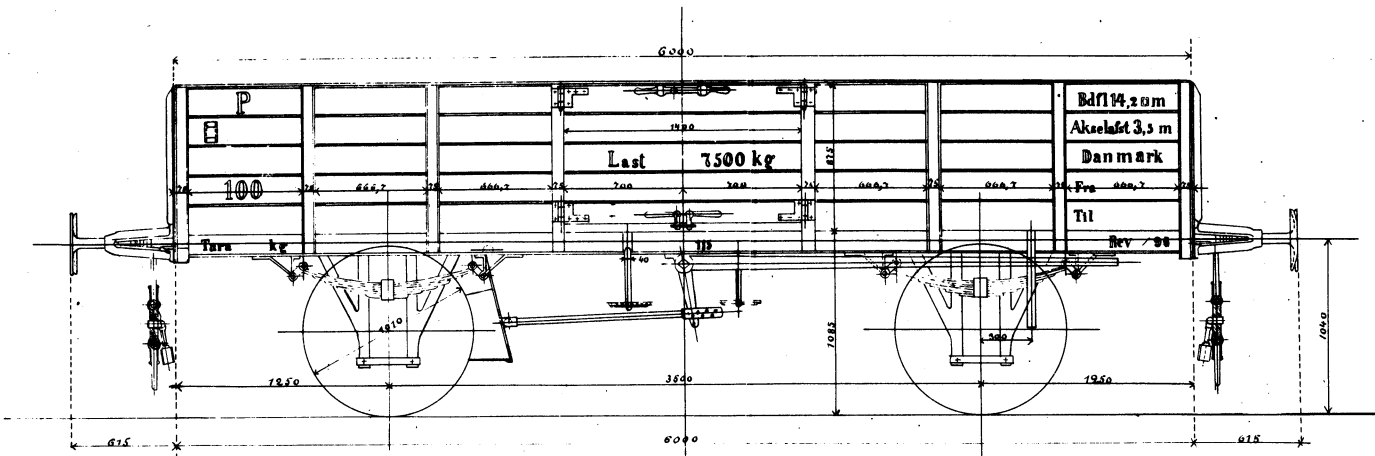

Aaben Godsvogn
 med Haandbremse
 Bæreevne 150 Ckn: Bundflade 14,20^m

Mails Juni 1896

123.B

FFJ Pa 603-612

Tor 6912.

Larsen i mester.

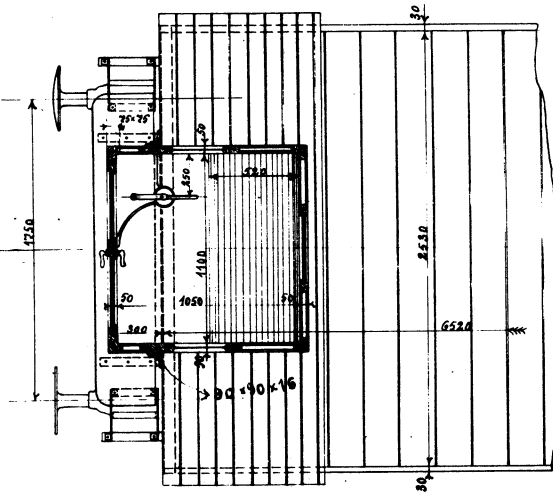
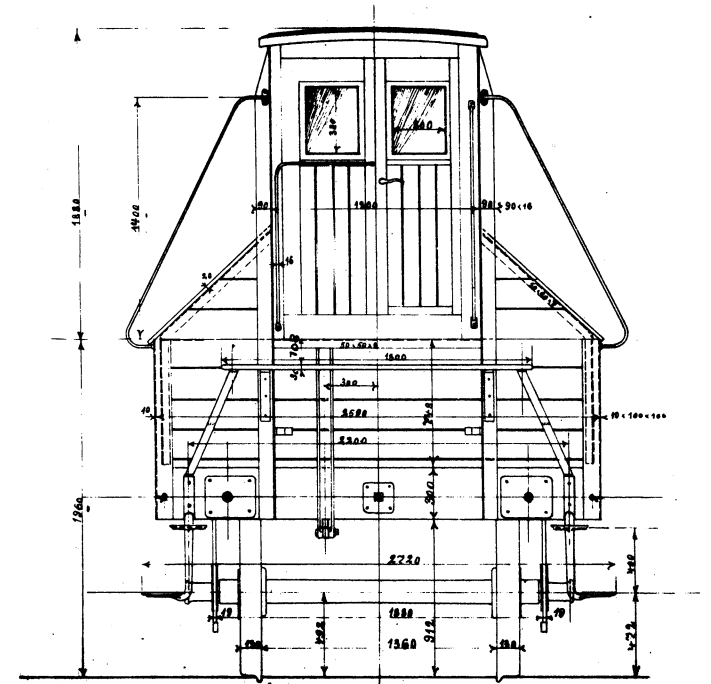
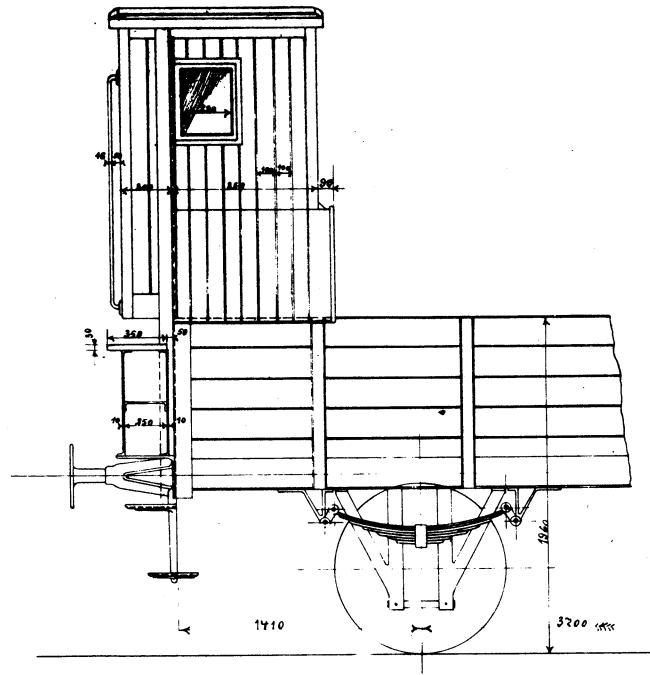
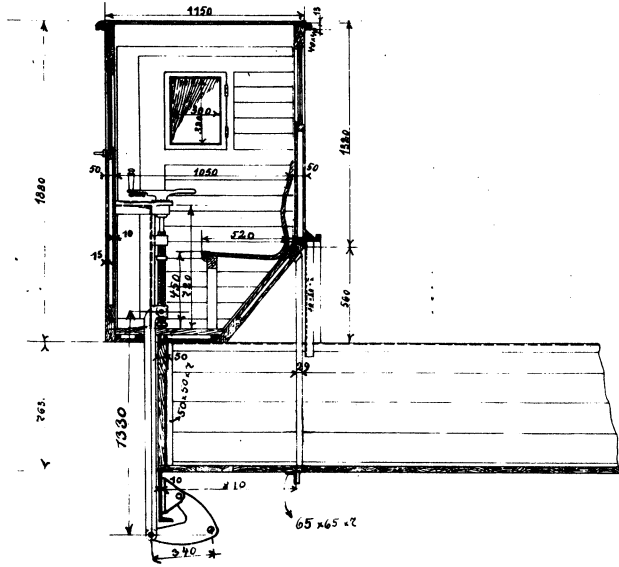

Bremsehjul til Staben havsiden Cydonovogn.
 til
 Nordsjællandsk-Sæby-Banen.
 til Tegning Tor. 6327.

Larsen i Junius 1900
 Bredt

(resten af vognen se tg. 6327)

FFJ Pb 771

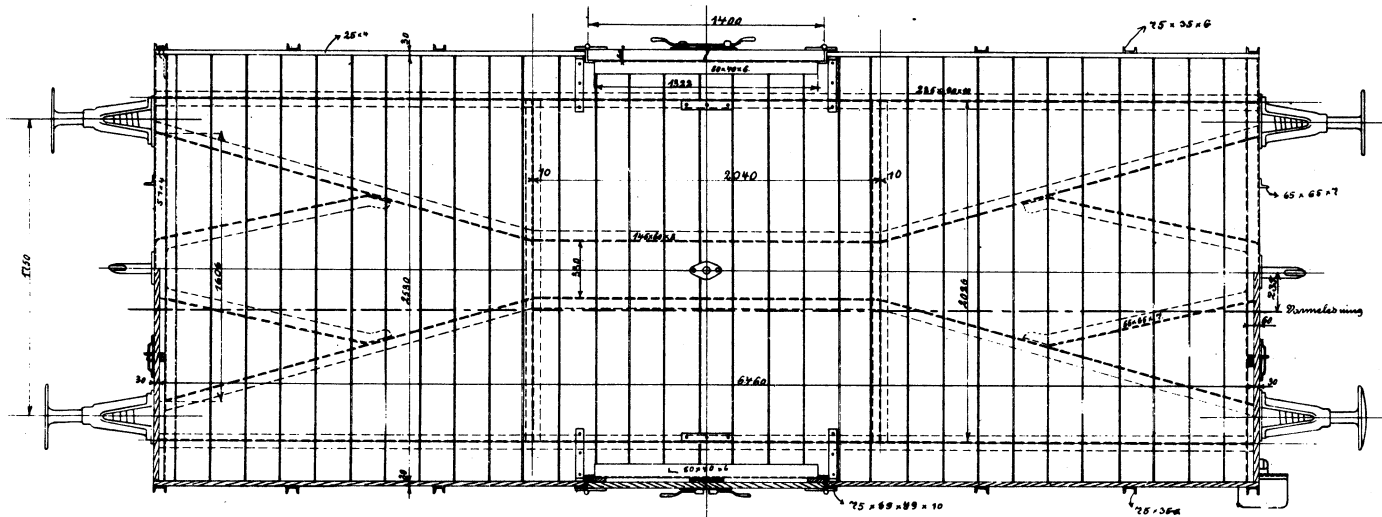
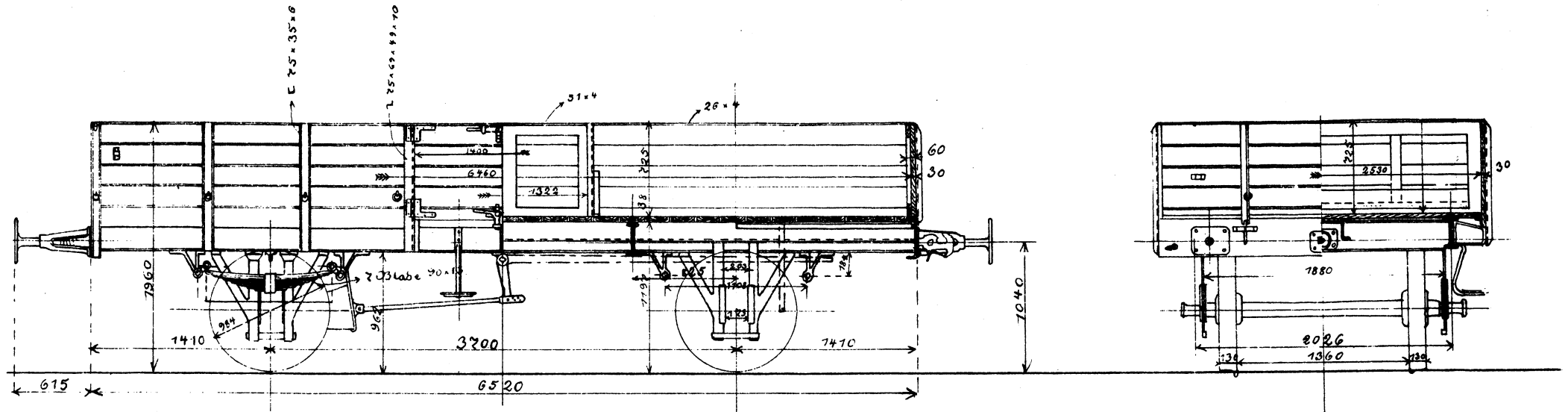

Ståken karvirket Lybøl

FFJ P 616-623

AHJ Pf 4701-4705

FFJ Pb 772-780

(med løse sider)

nr. 6326.

Scandia i Randers.

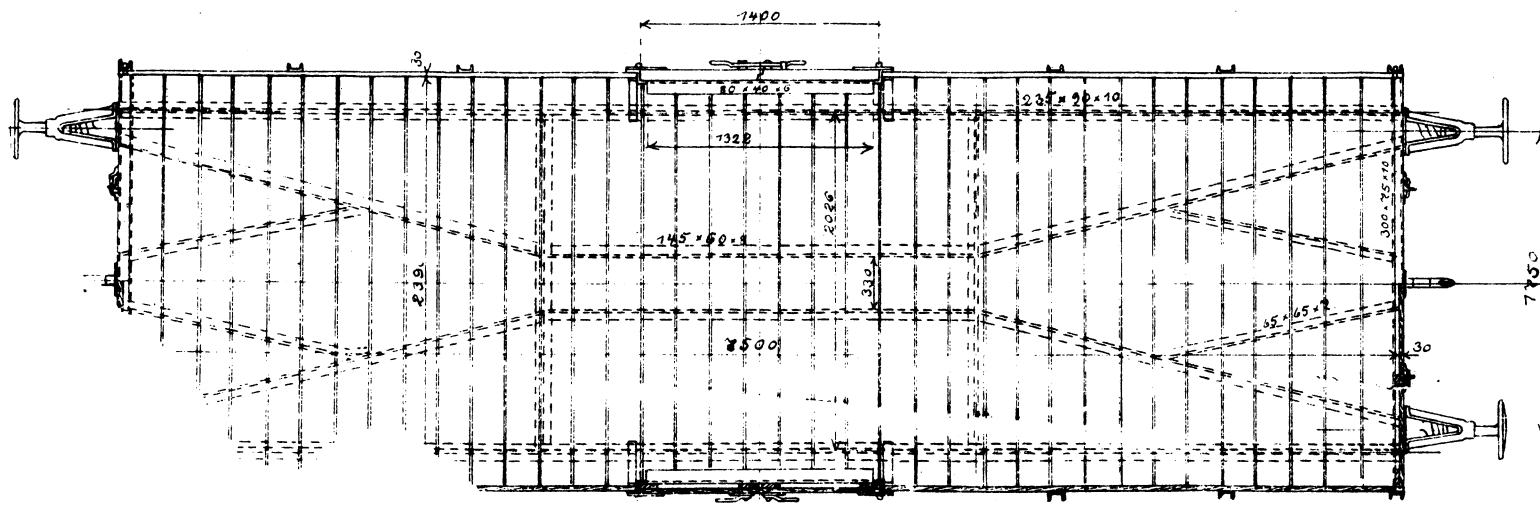
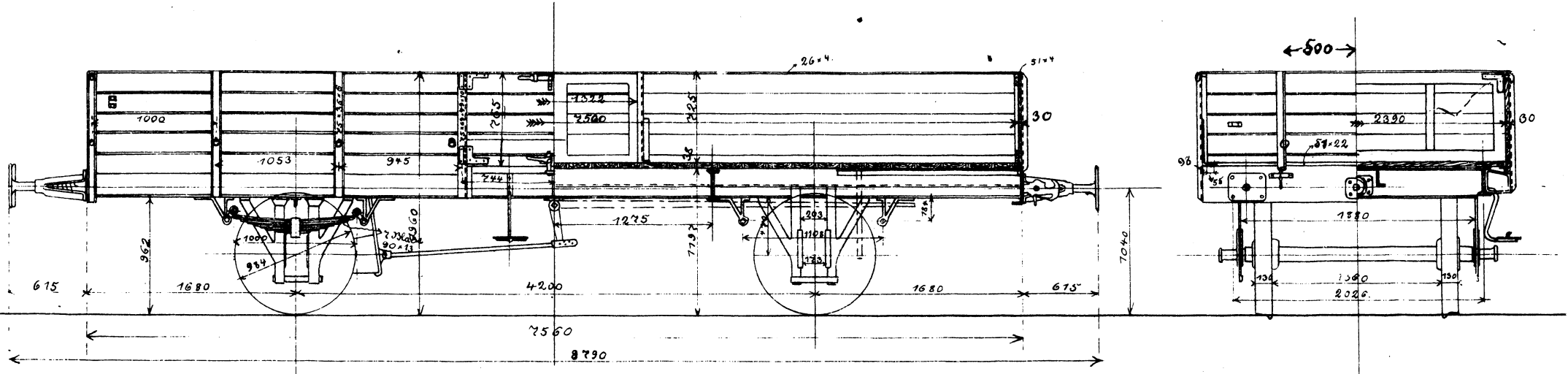

Lang aaben lavsidede Godsvogn
Type B.
til

Horsensby-Sæby-Banen.

Scandia
Monsbo
6326
Bredbo

FFJ Pf 801-808

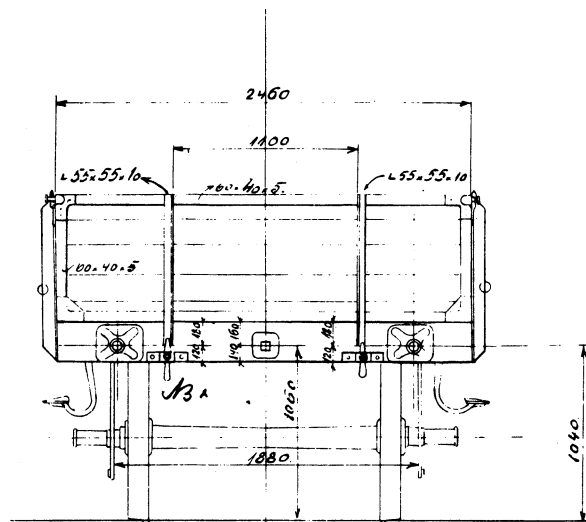
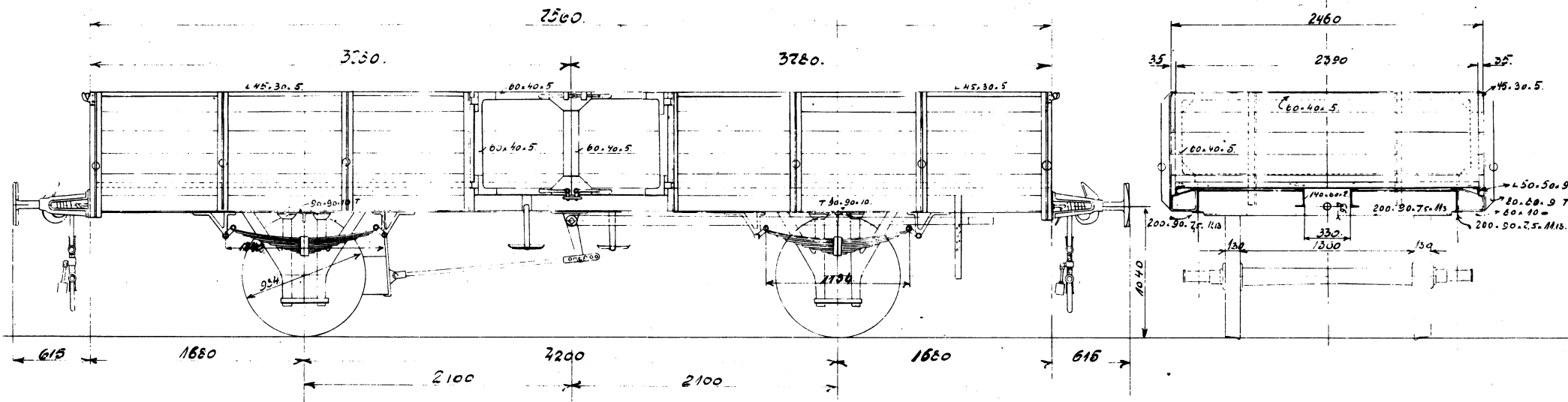

Nordjyllands Jernbane Privatbaner.
 Maskinafdelingen.

Akten Godsejeren
 Litra B.

Litra B.

Aalborg August 1906.

B. Hjulplade flyttes af i Hvide
 med Biffenplanke overkant.

Uindret 55x55x10 afkeres derfor

FFJ Pf 844-849

AHJ Pf 4875-4876

AHB Pf 2893-2894

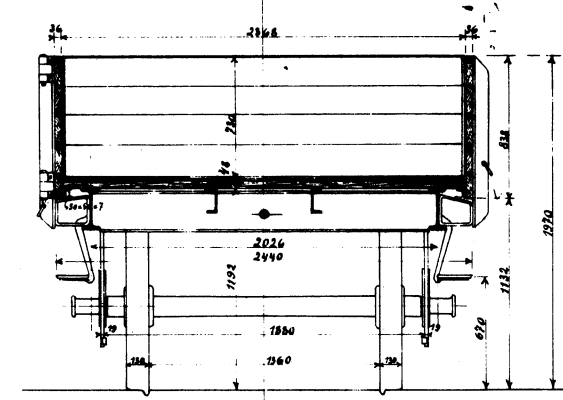
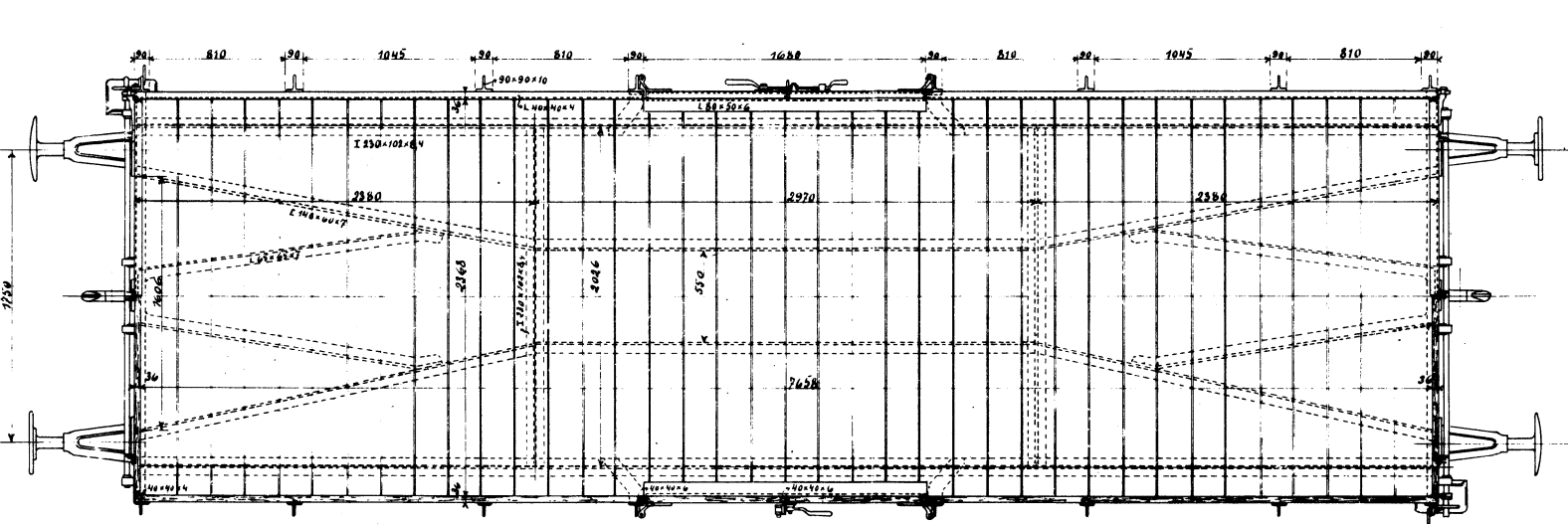
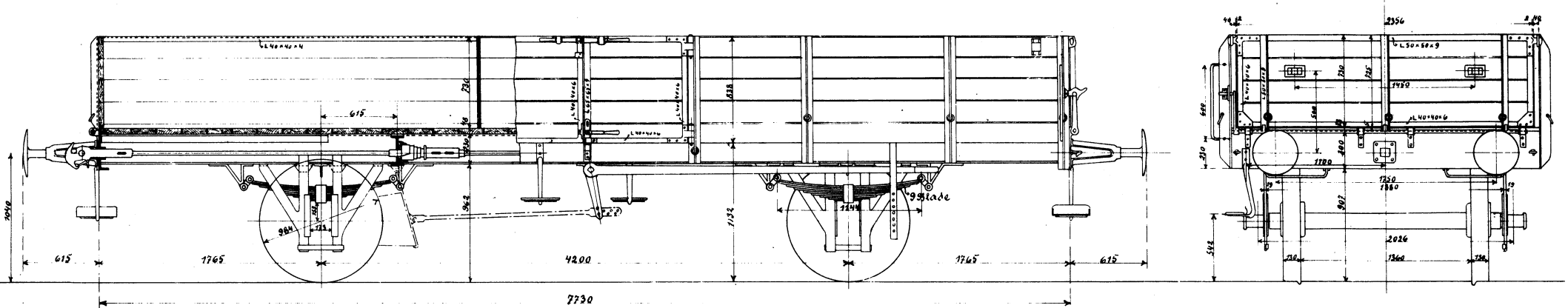

Åaben lavsidede Sodsvegn
 kil
 Nordjyllands foren. Privatbaner.
 Opre 1211.

FFJ P1 860
 FFJ P 951-966
 AHB P 2905-2907
 AHJ P 4921-4923

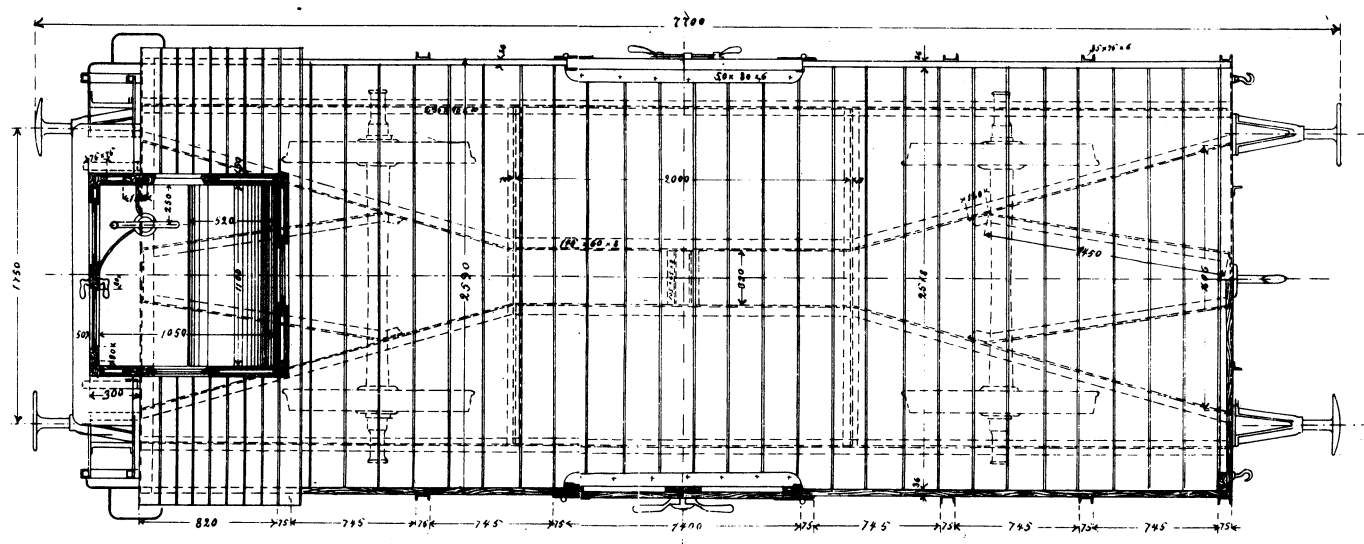
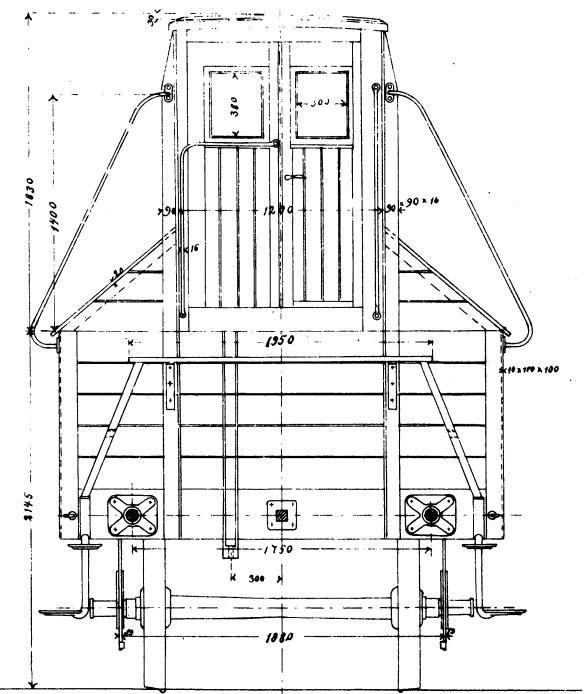
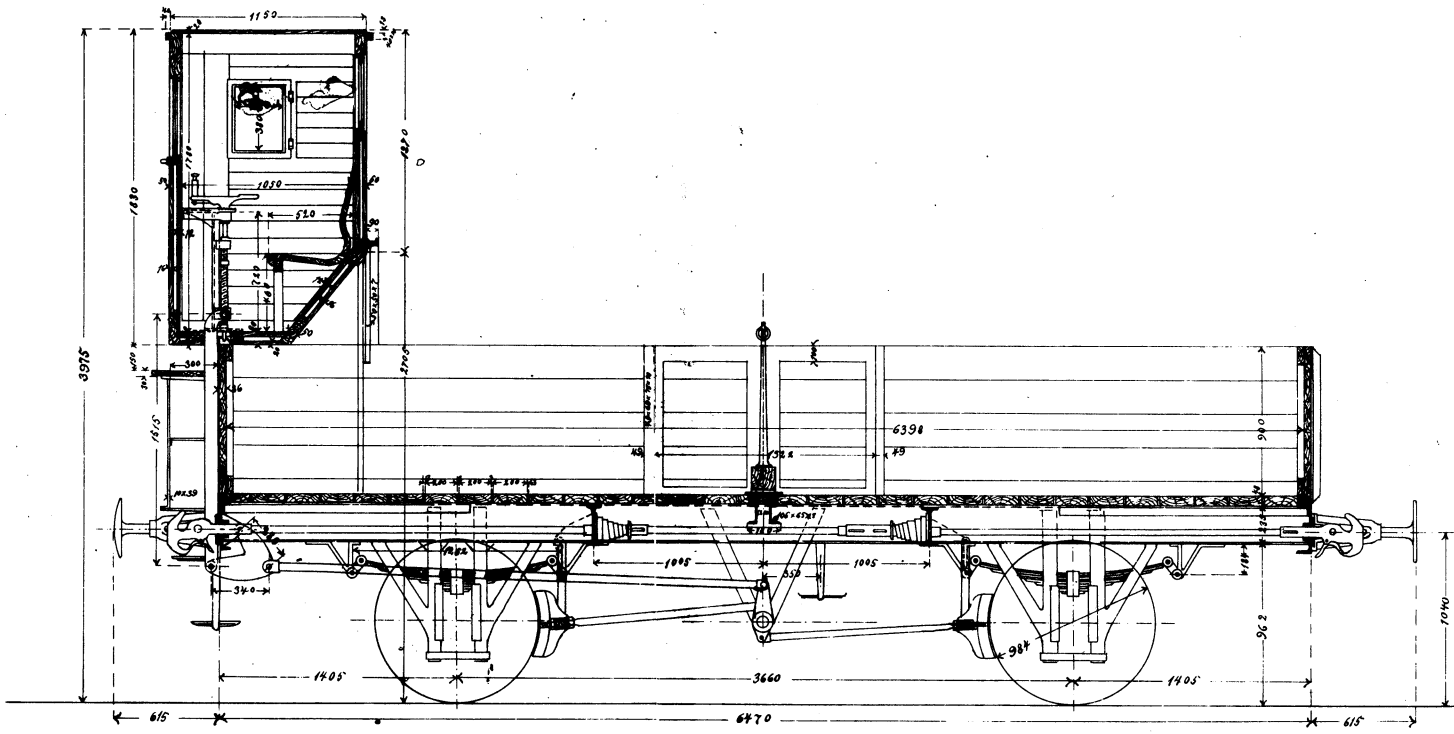

Køben lavsided Godsvojn

med og uden Skrubremse.

Skaribod 3/2 1895

*g.m. Skaribod 98
1895*

AHB P 2671-2672

skrubremse

AHB P 2673-2676

håndbremse

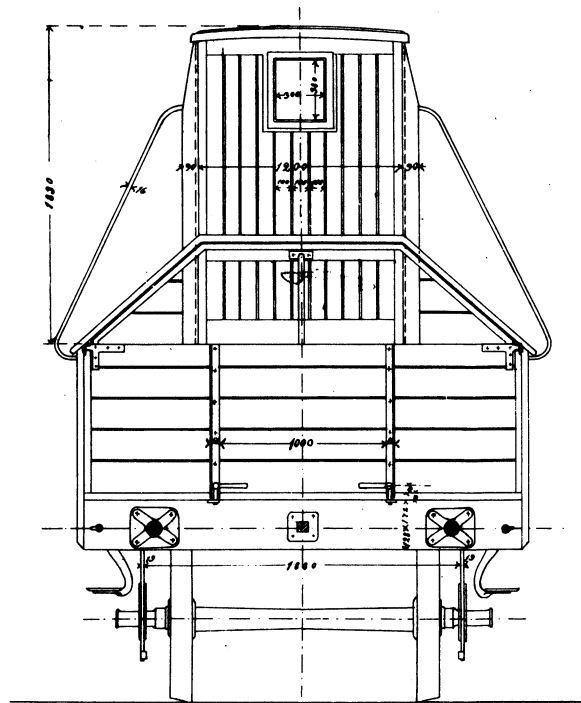
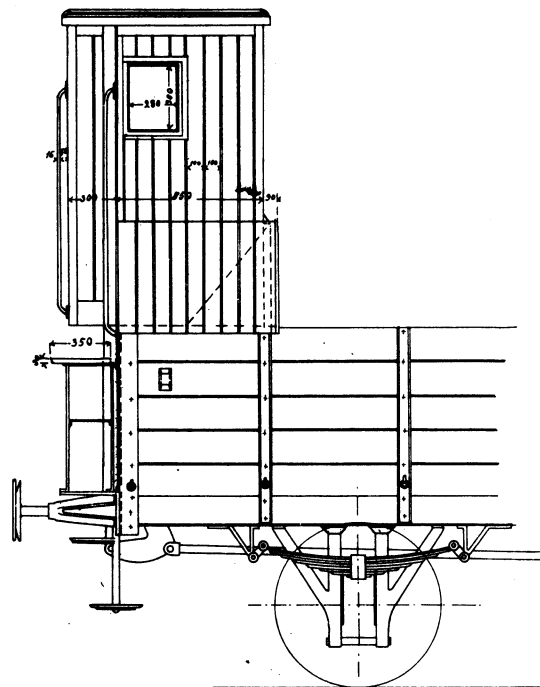
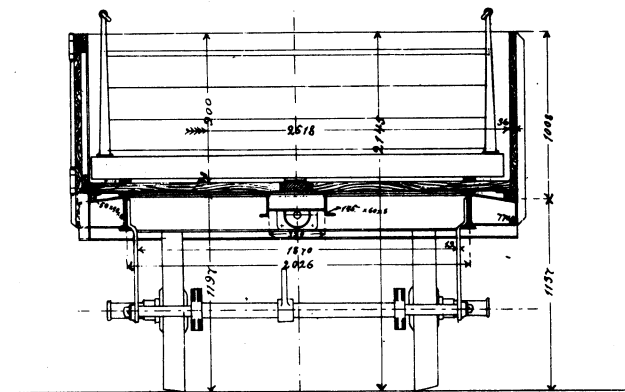
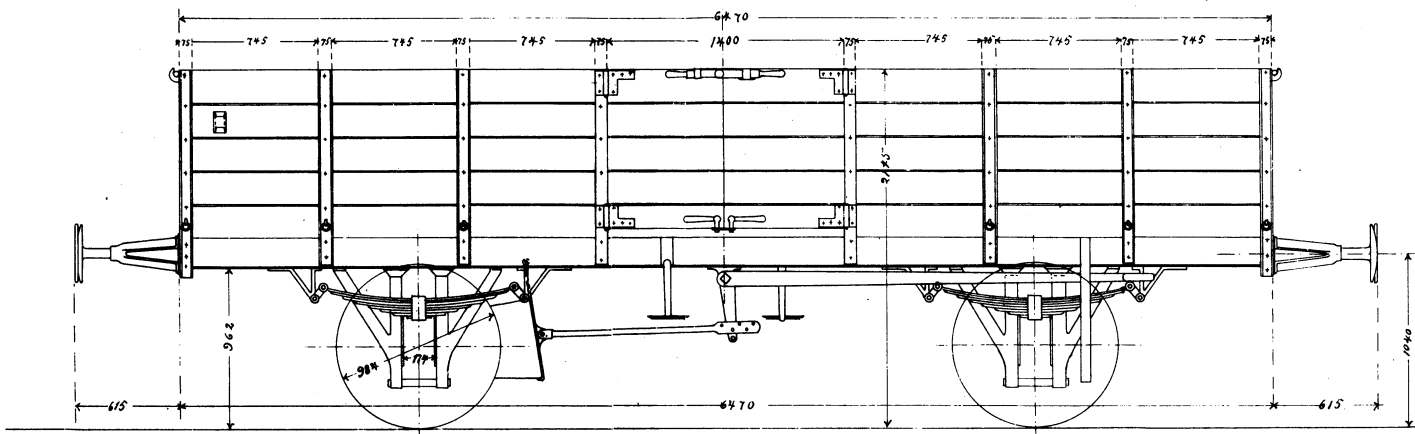

AHB P 2671-2672
 AHB P 2673-2676

№ 6933.

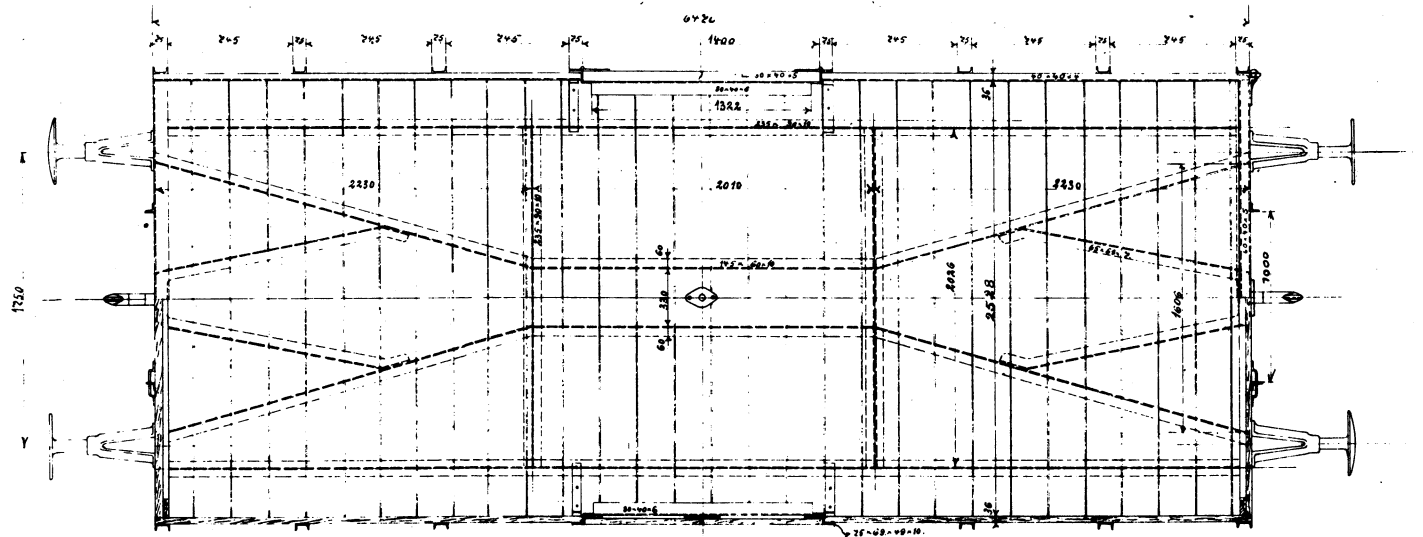
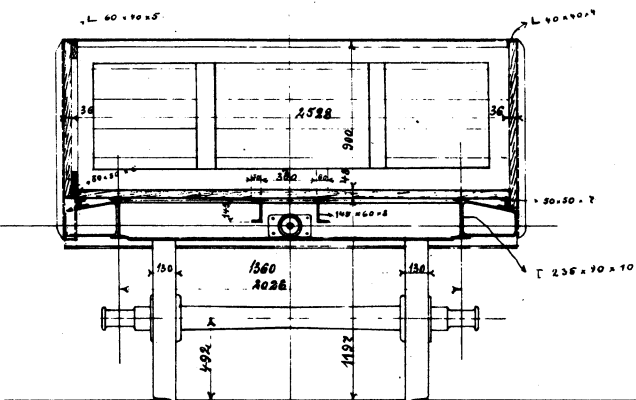
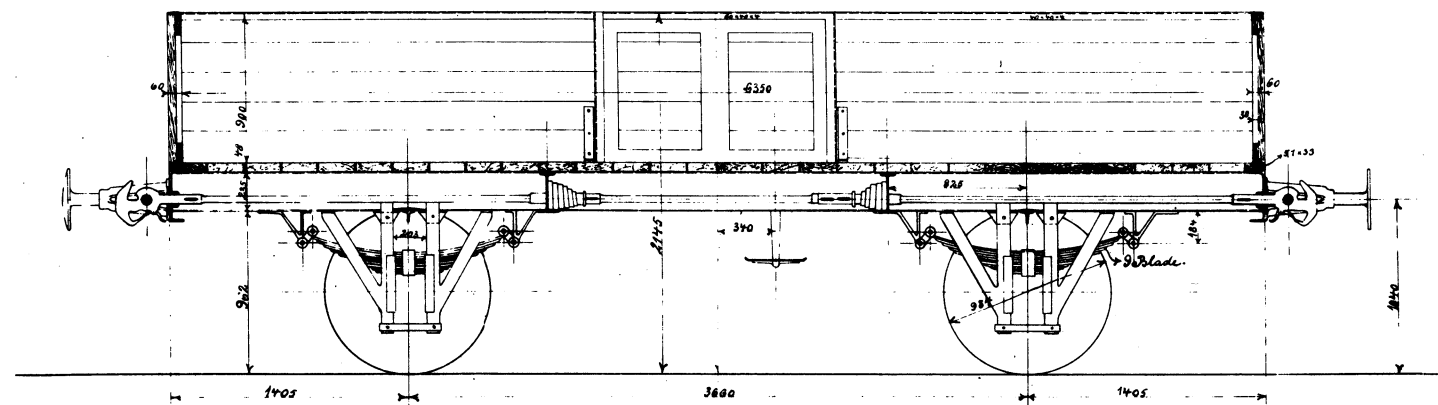
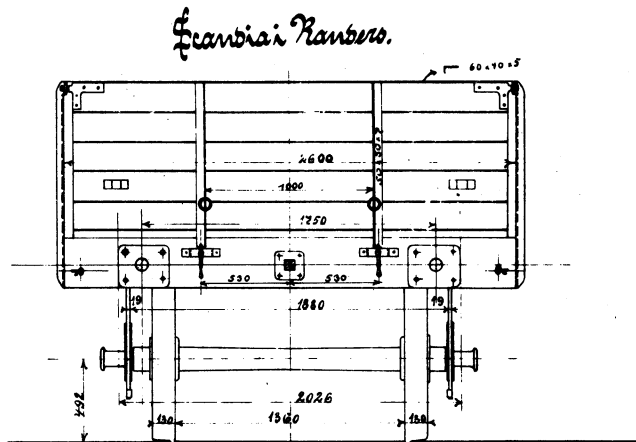
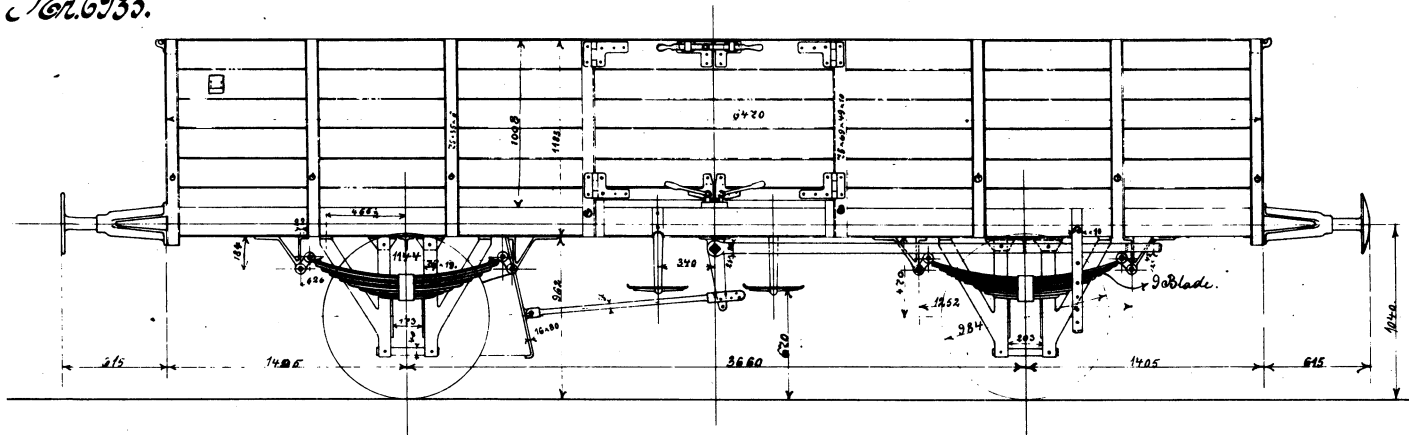

Работы лавинной системы.
к
Строительству Баней.

Order 214.

AHB Pf 2677-2678

Nr 8857

Scandia i Randers

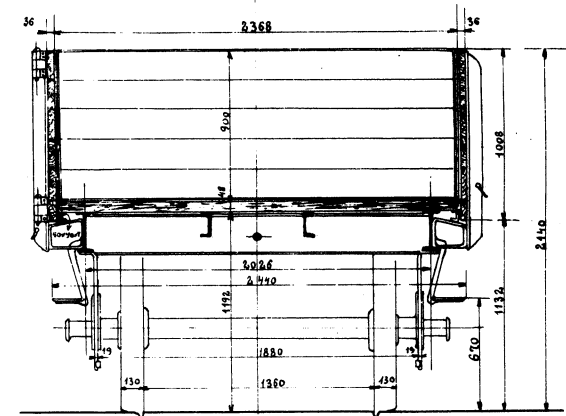
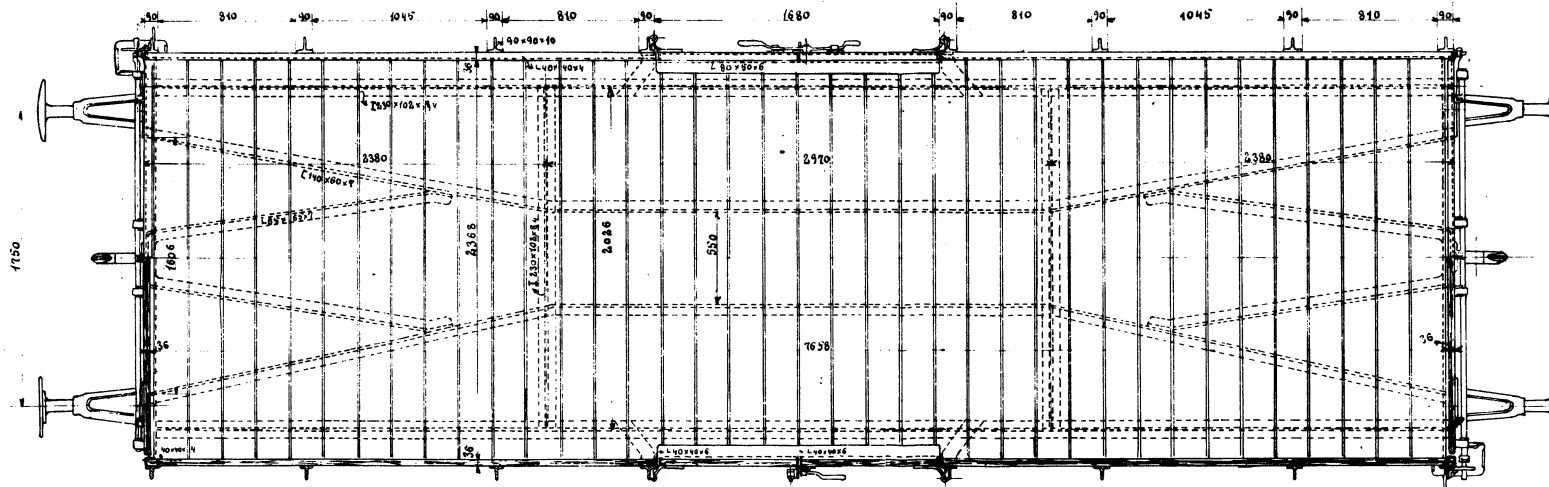
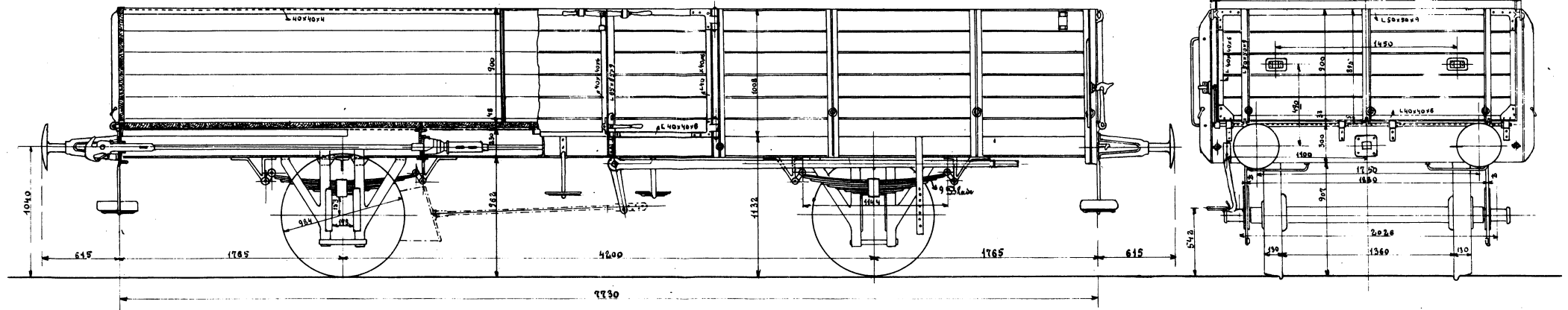

Aben lavsidede Godsvogn Ek. Sf.
kil

ordfynske-Tunbar

AHB Pf 2900-2904

AHJ Pf 4879-4881

AHJ Pf 4883-4890

Scandia, 1909
W. Lauritzen

Deutsche Werke

A. G.

Werft Kiel.

Zweiachsiger Güterwagen ohne Bremse.

Tragfähigkeit: 15,75t.

Maßstab: 1:25.

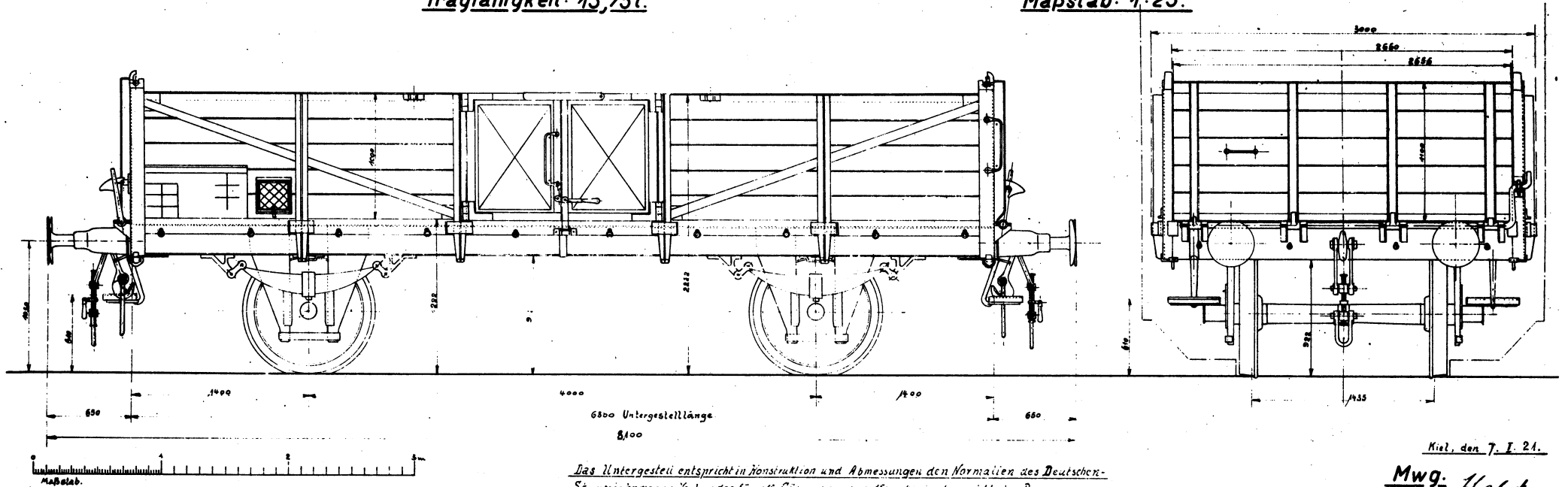

Kiel, den 7. I. 21.

Mwg. *Heldt*

opr. uden bremse, senere håndbremse

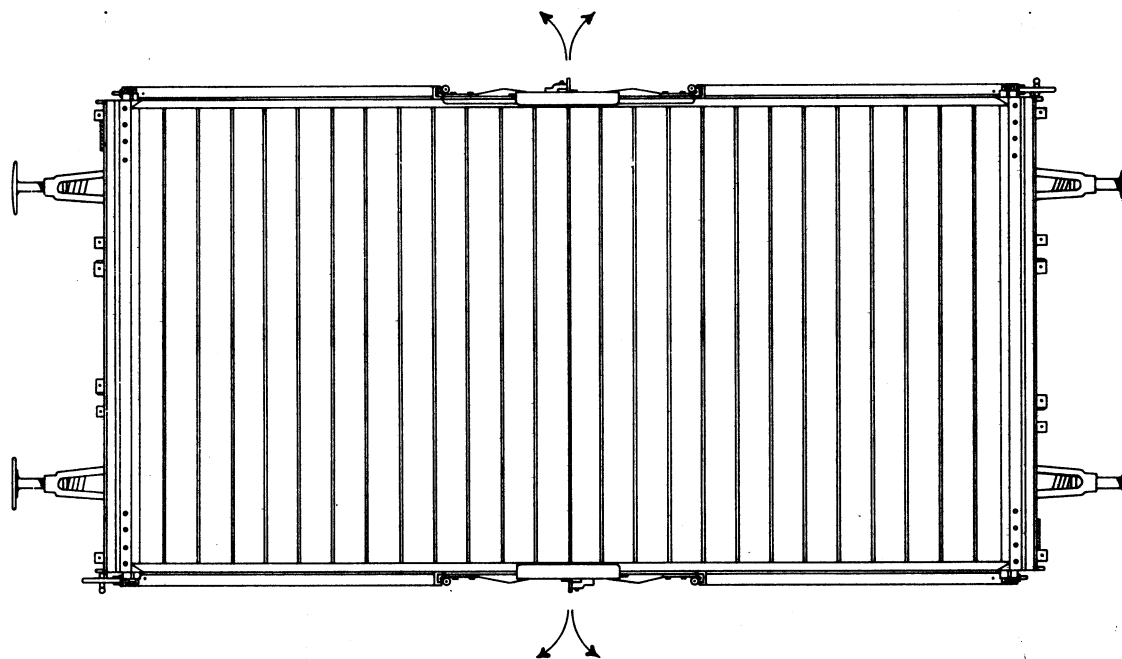
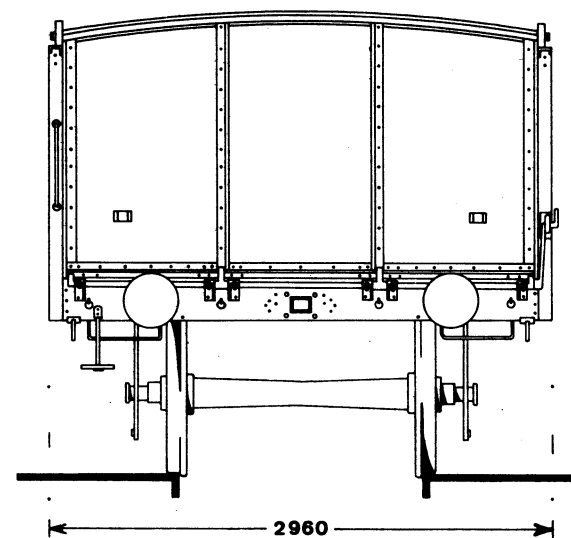
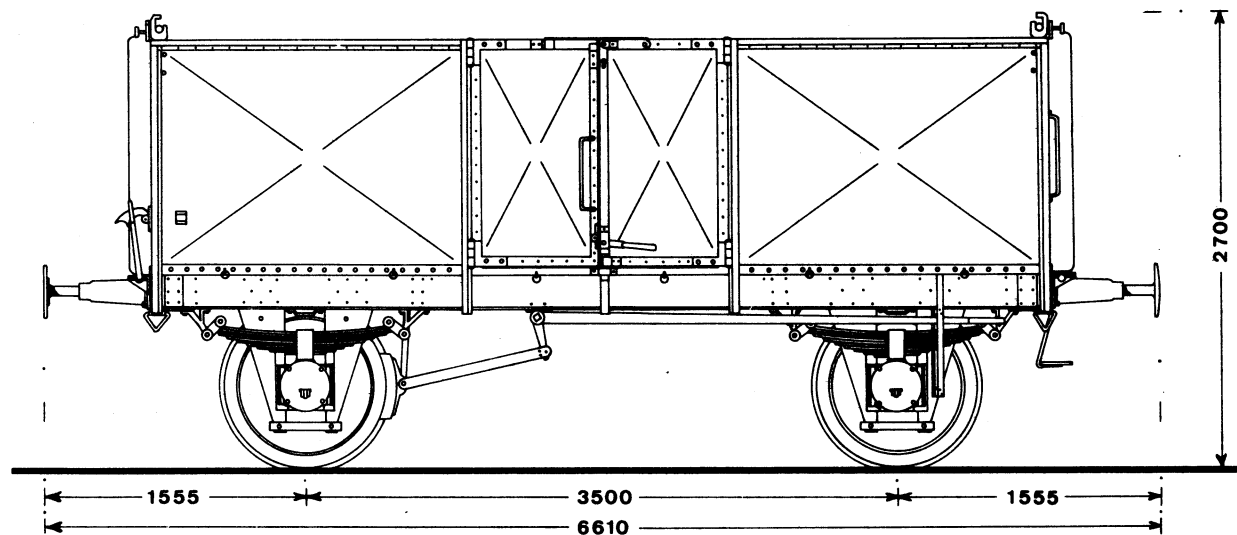

FFJ Pu 1311-1317

Pu 1313 havde rangerskruebremse

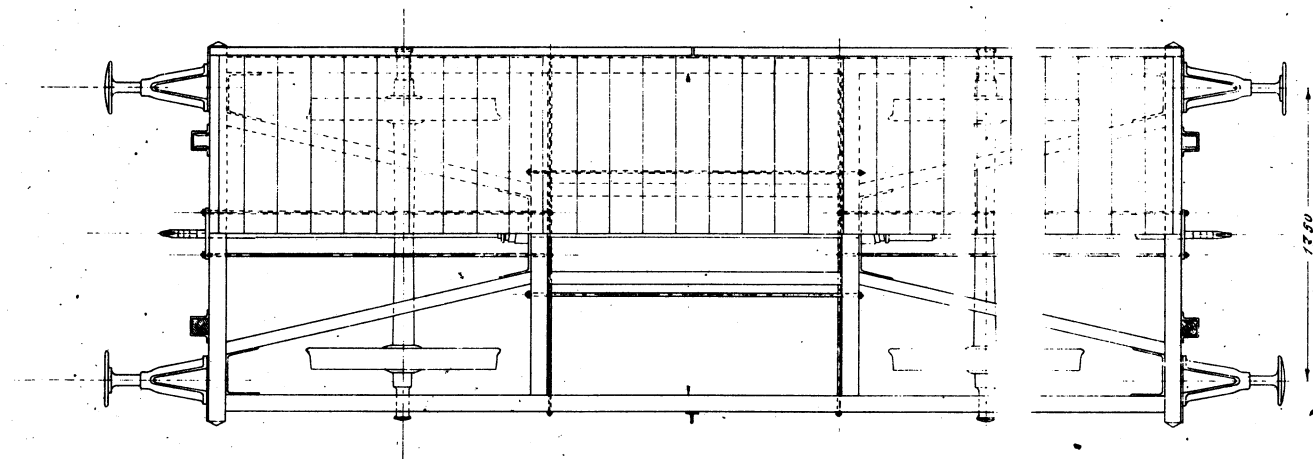
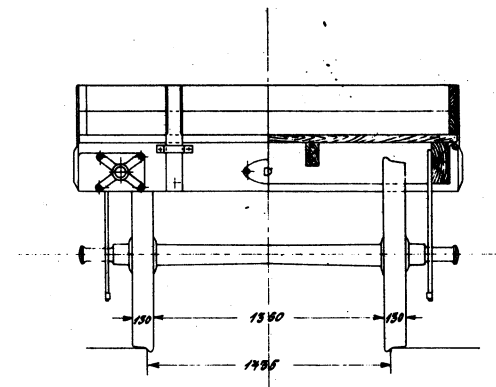
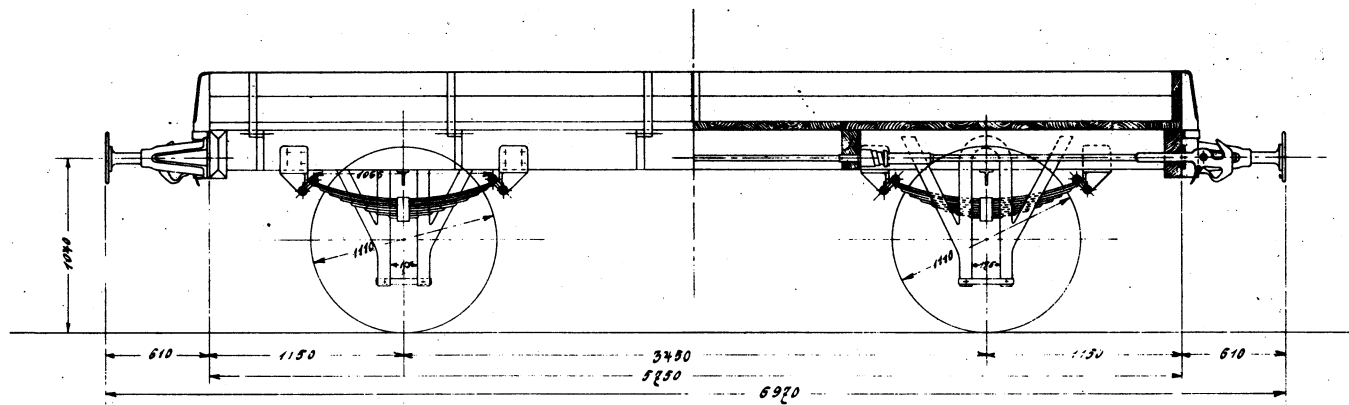

Nordjyllands forenede Privatbaner.
 Maskinafdelingen.
 Ballastvogn Bdf 12 - Mtr.

Rekl. og i'dannelse 1908.

Projekttegning

FFJ Ta 1009-1015
 AHB Ta 3001-3004
 AHJ Ta 5005-5007

Nr. 9408.

Scandia i Kanders.

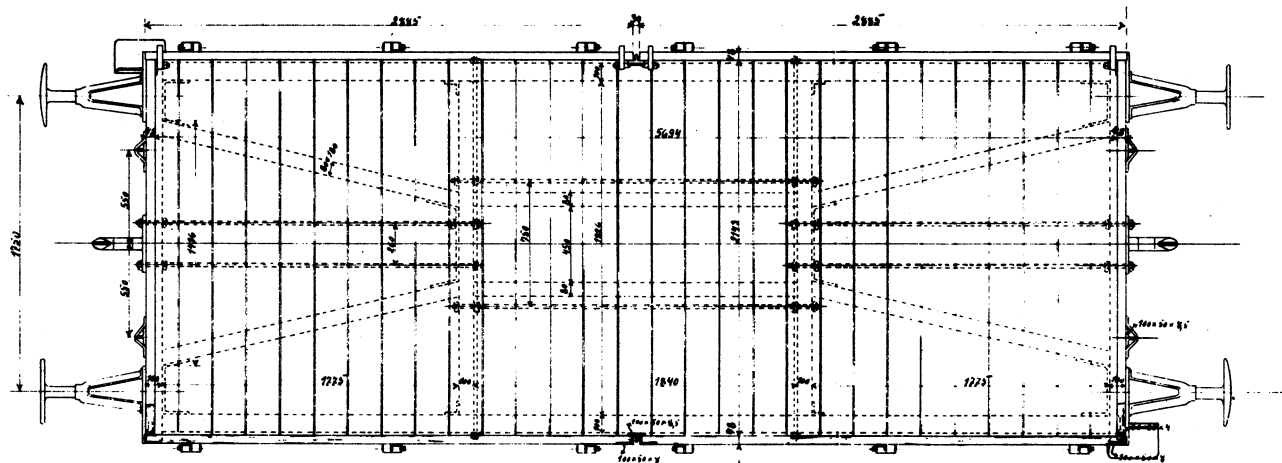
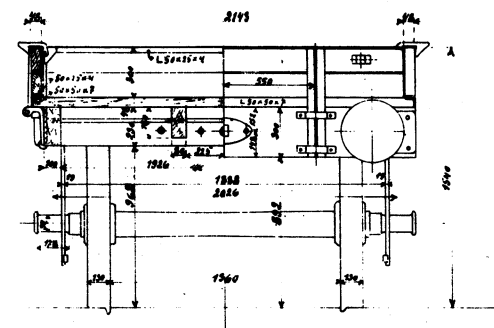
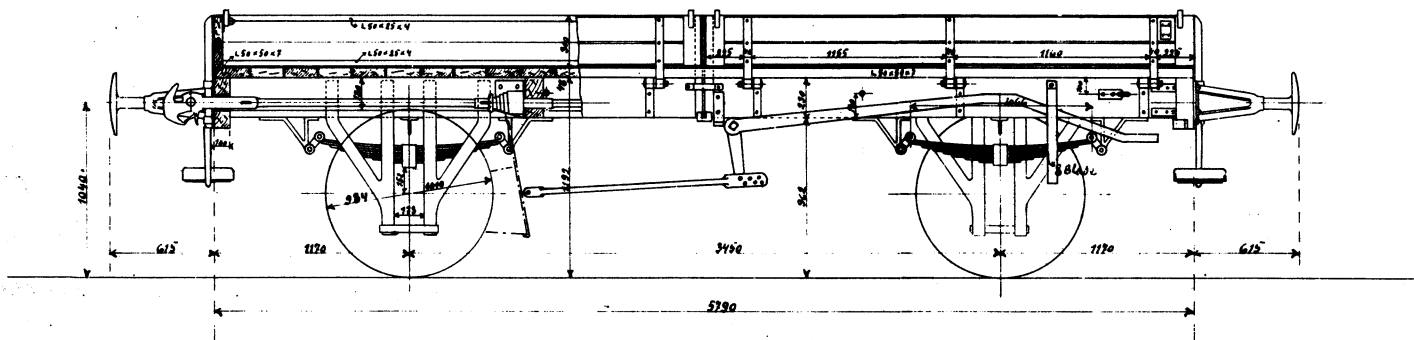

Ballastvogn
 til
 Nordjyllands Jern- og Privatbaner.
 Ordre 975.

nr. 122.3 26.13.

Scandia, 1913
 Kanders

FFJ Ta 1024-1025, 1027-1028

AHB Ta 3023 og 3029

AHJ Ta 5026 og 5030

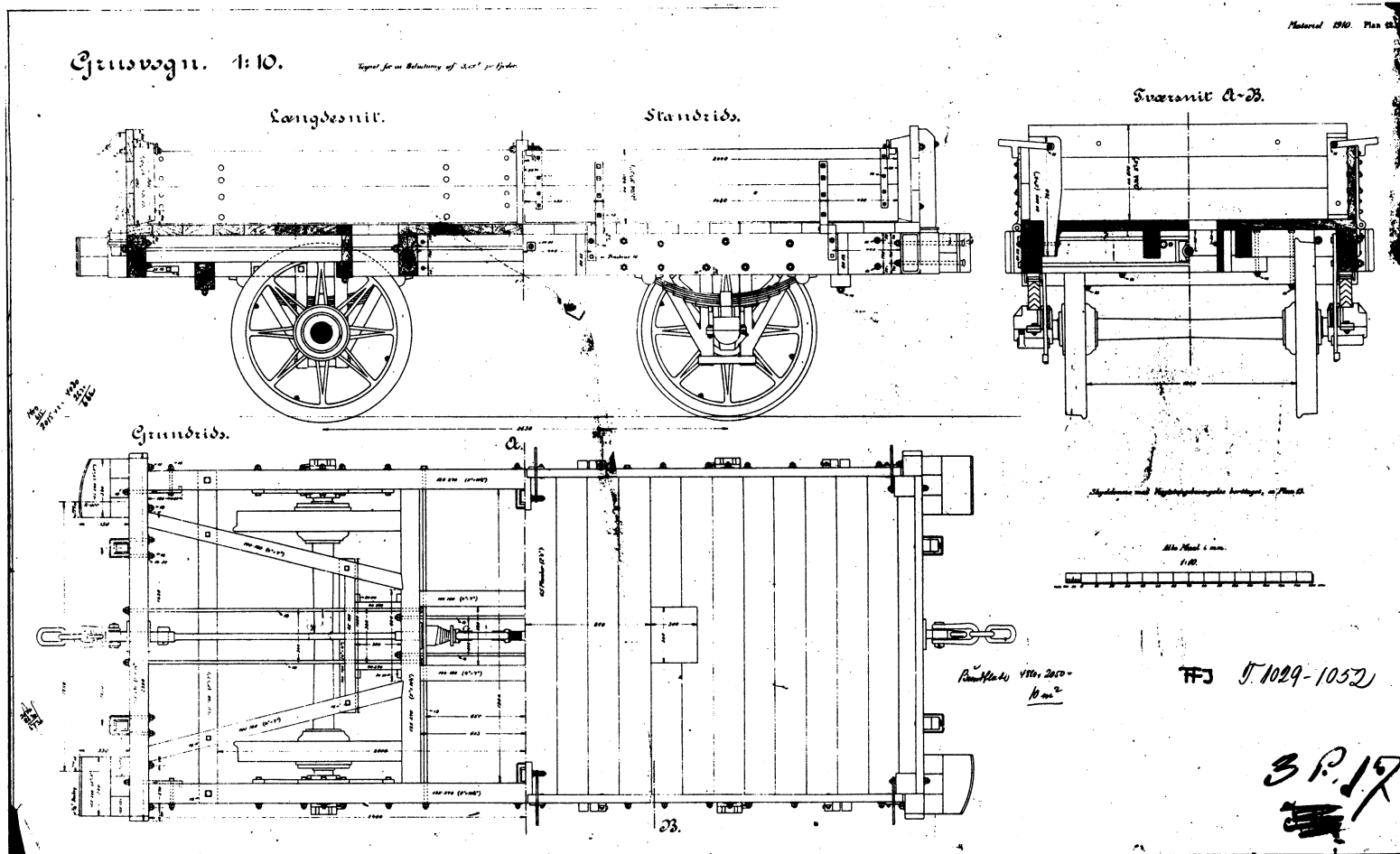

enkelte vogne forsynet med skruebremse, resten fik håndbremse

FFJ T 1029-1052
 AHB T 5009-5020

RITN N:3443.

ÖPPEN GODSVAGN LITT N₁ MED HANDBROMS. SPÅR 1435 mm

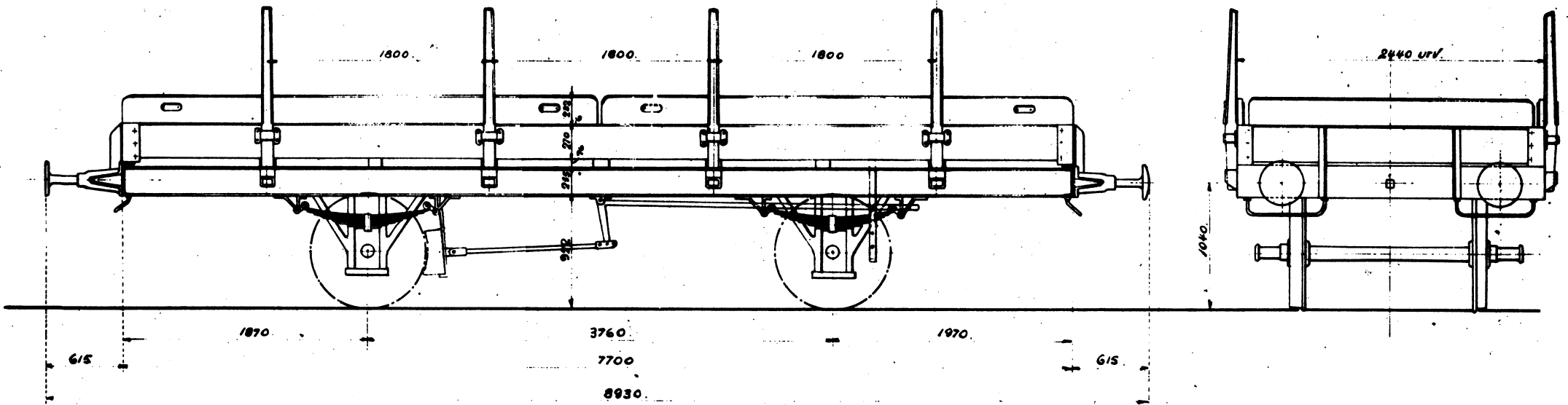

AKTIEBOLAGET
ARLÖFS MEKANISKA VERKSTAD
&
WAGGONFABRIK

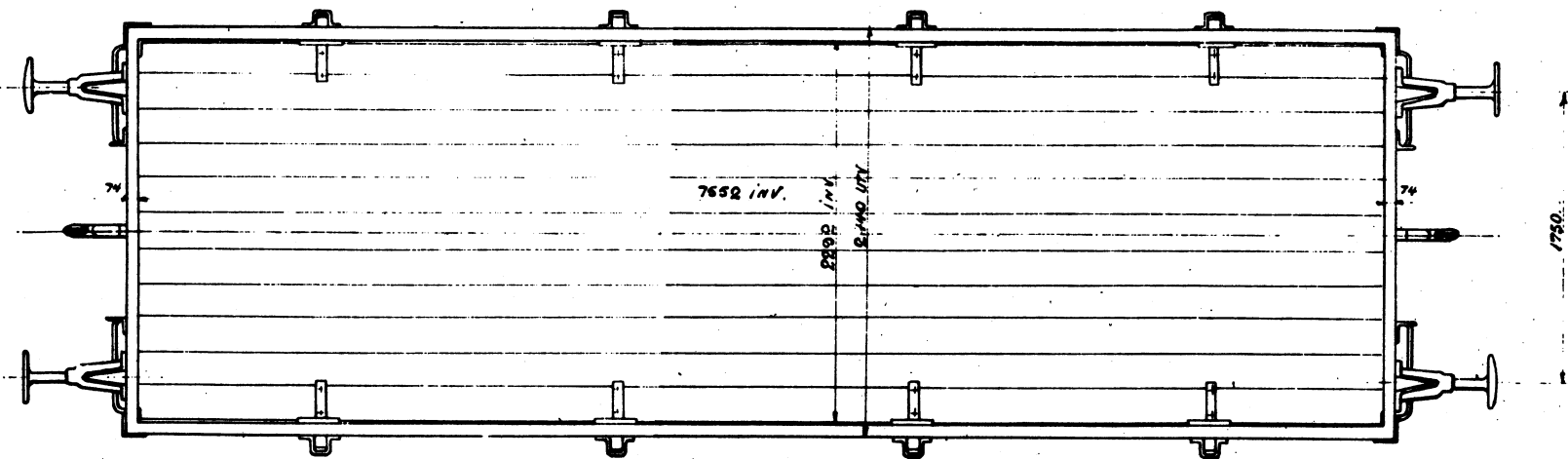

ARLÖF P. PLANIÖR
1897

AHB Tf 3017-3022

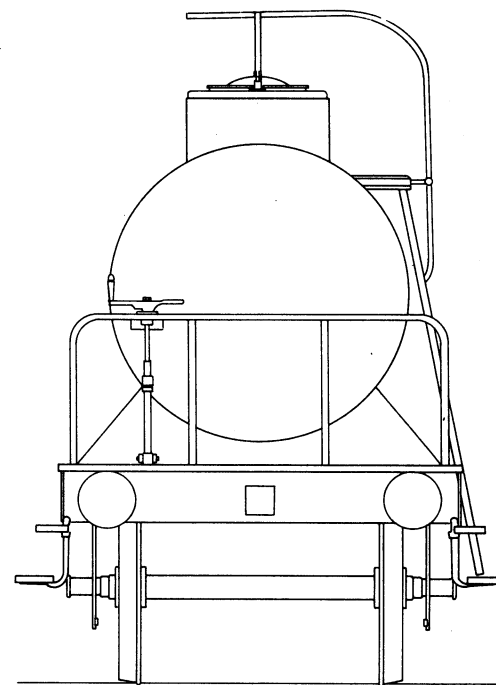
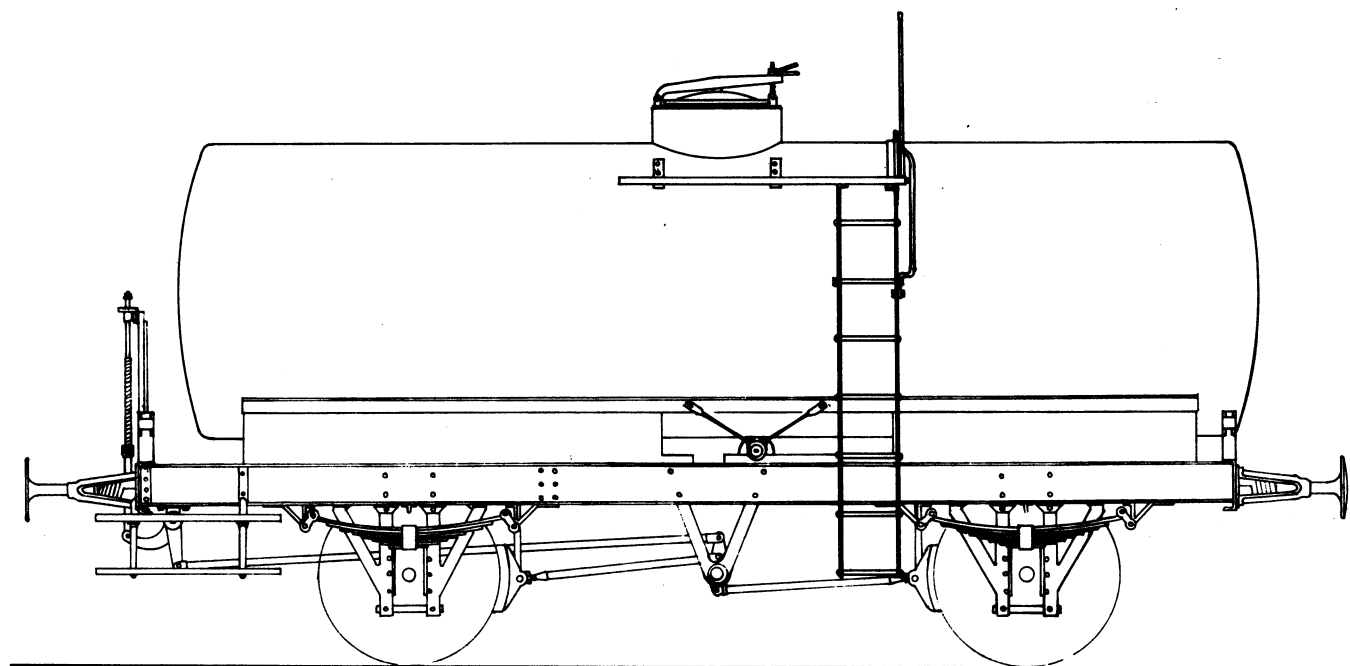

FFJ T 1011

Snejslov.

Hälsöhamn - Sjöstenber 1898.

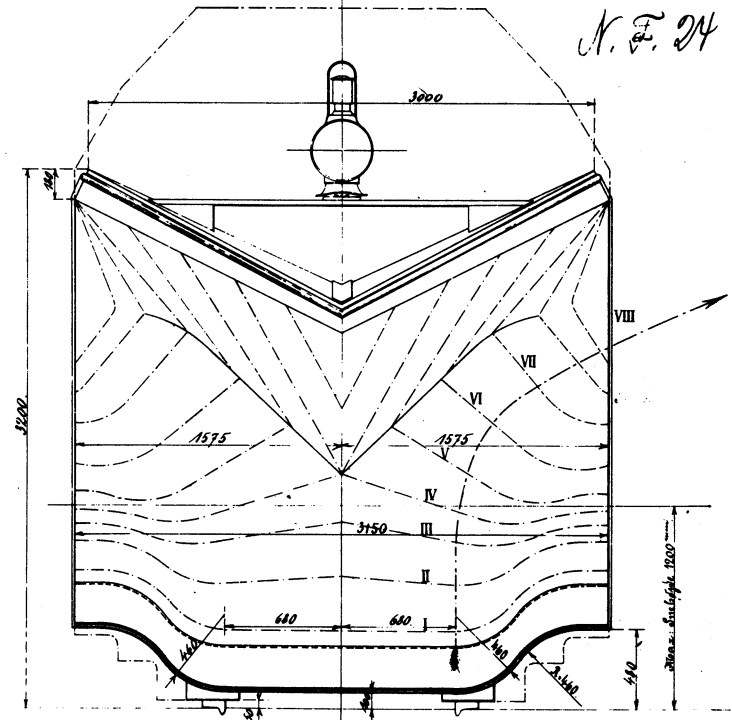
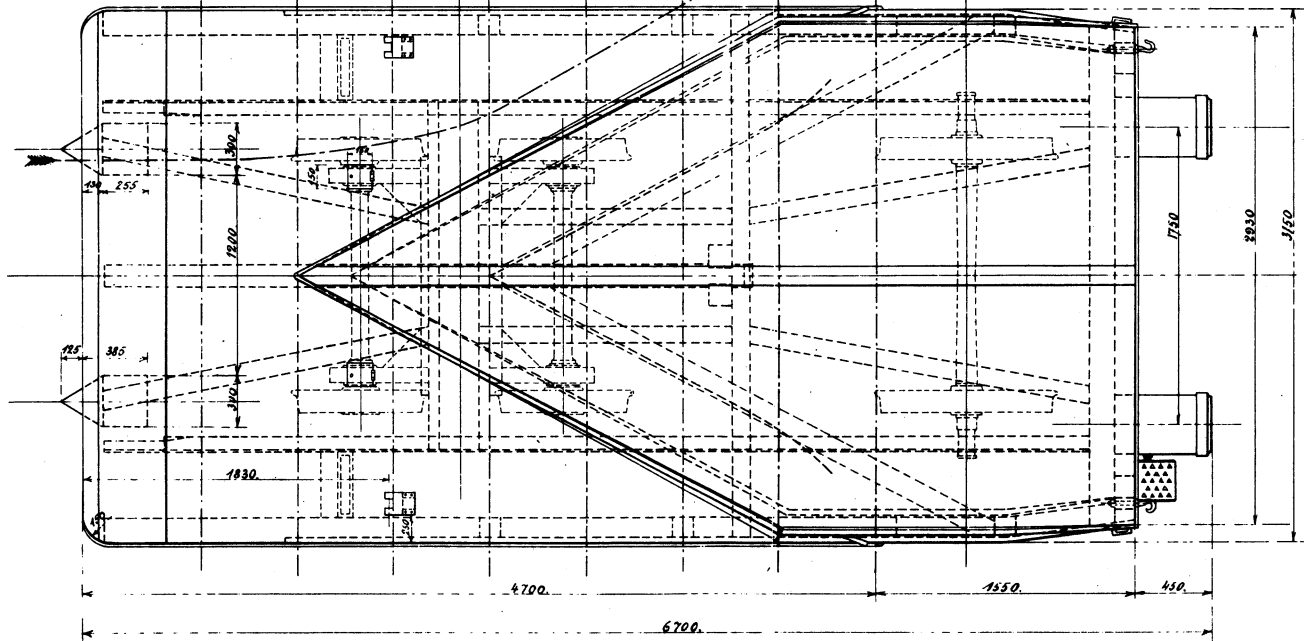
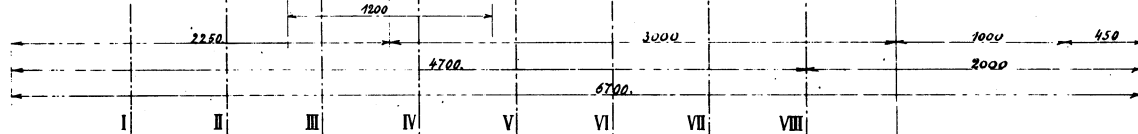
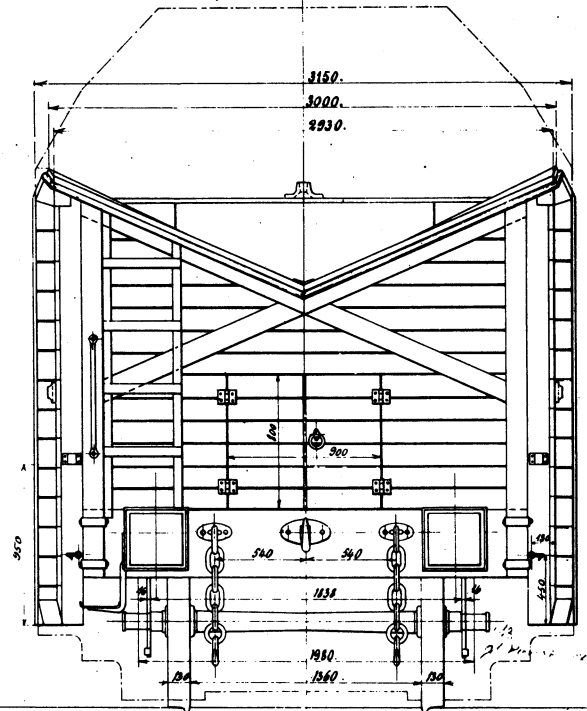
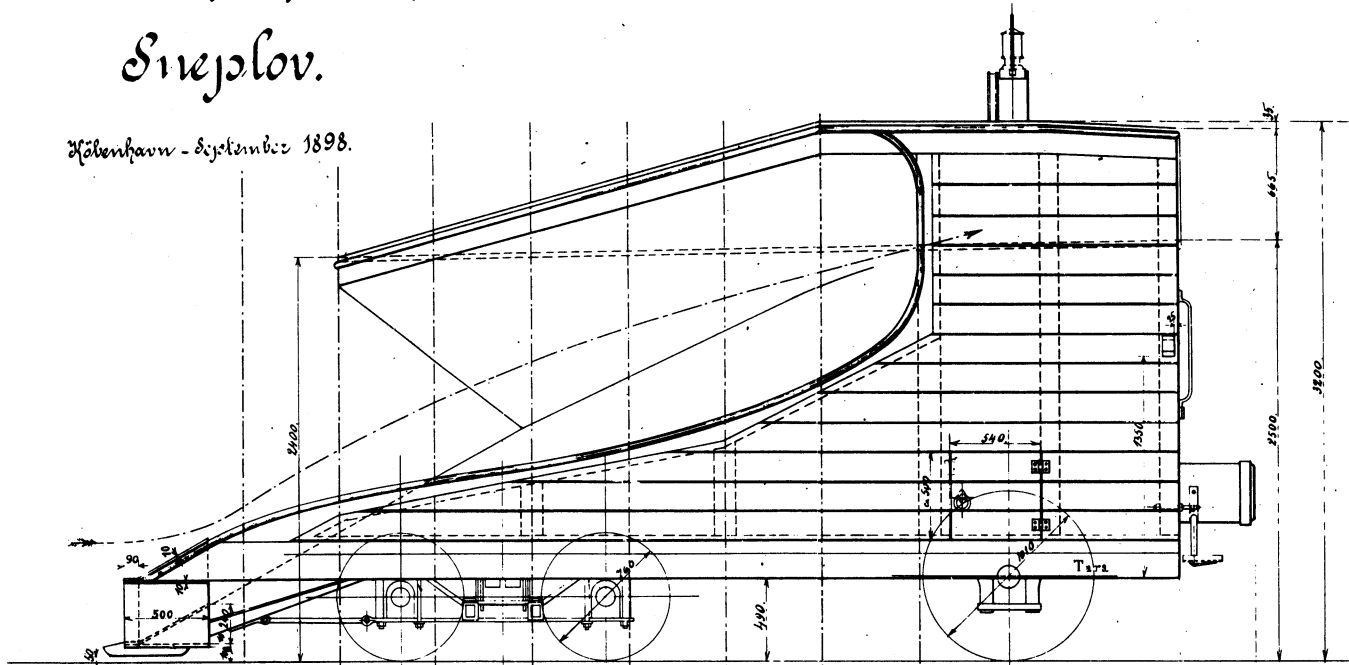

FFJ 2
AHB 3

AHJ 4
FFJ 5

(20% 1898)

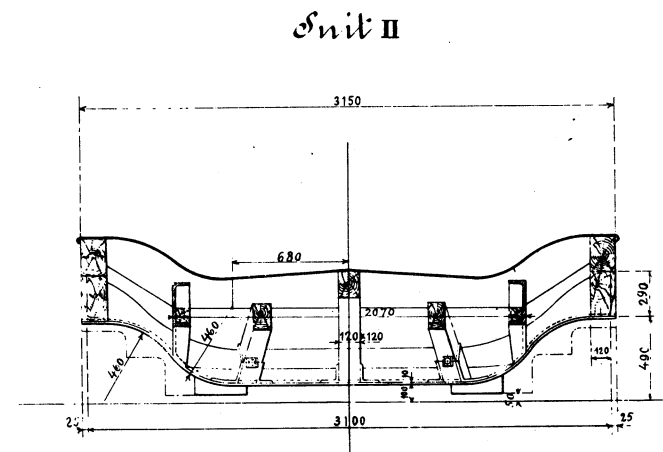
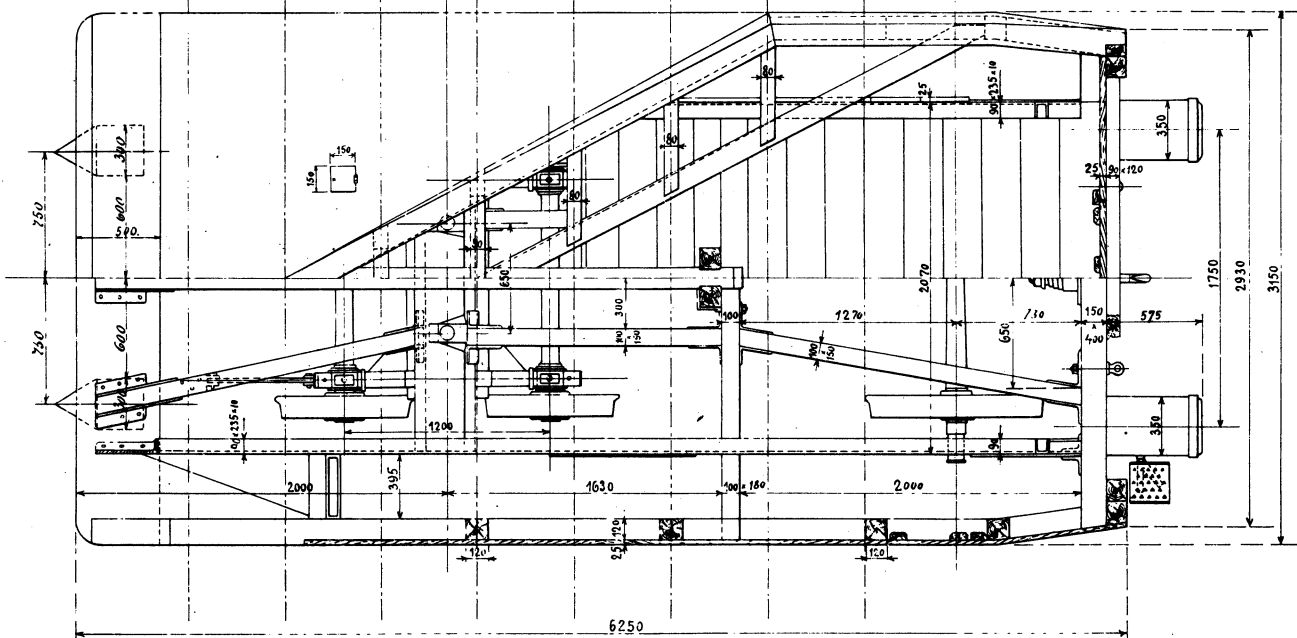
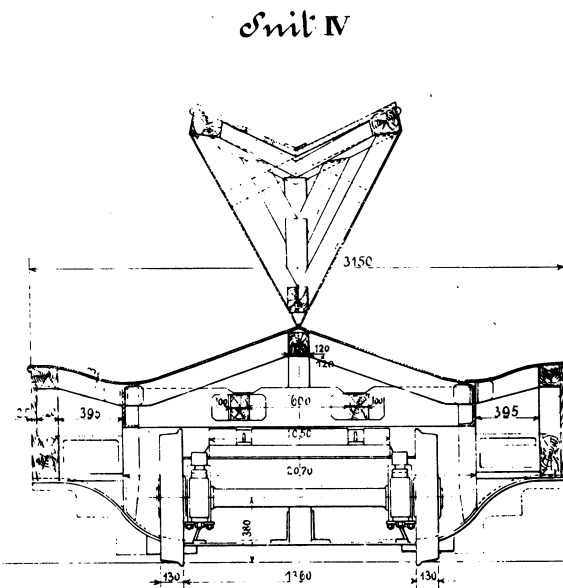
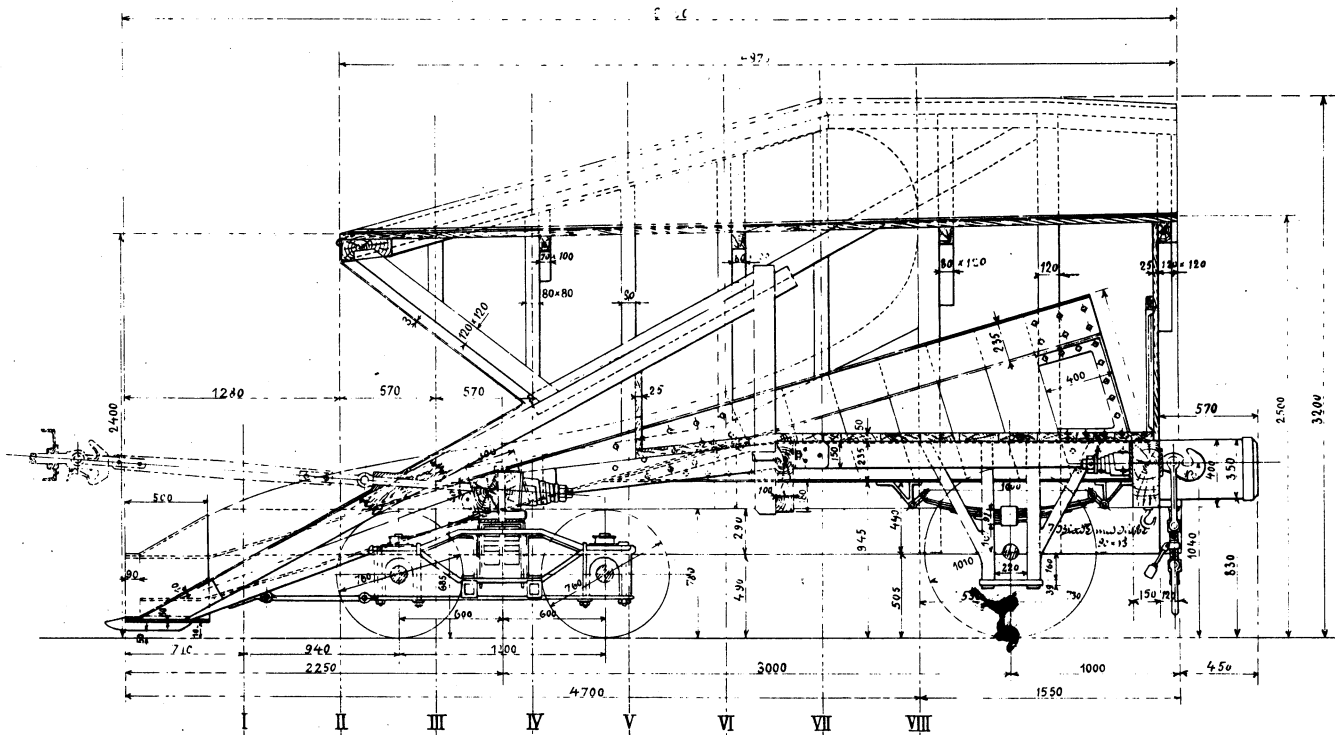

FFJ 2
AHB 3

AHJ 4
FFJ 5

3. 2. 1911
O. J. J. J.

Hörsundby - Søby - Frederikshavnbanen.

Snejlov.

1898

Höbenhavn - September

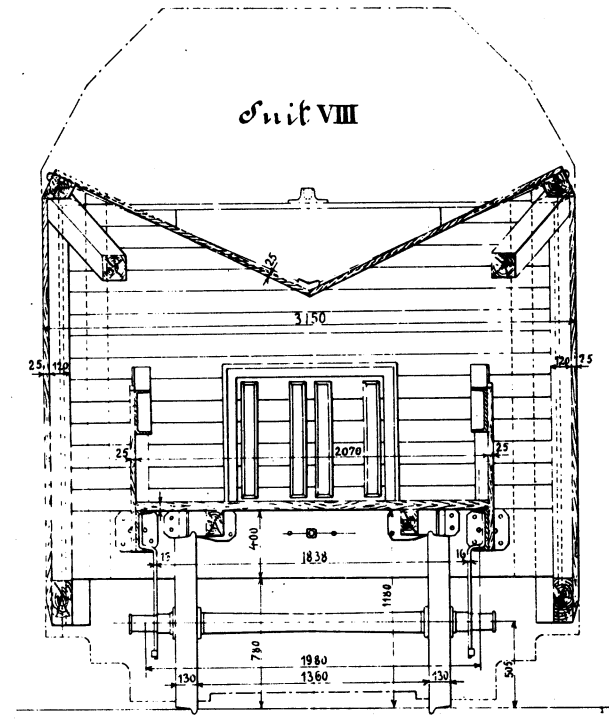
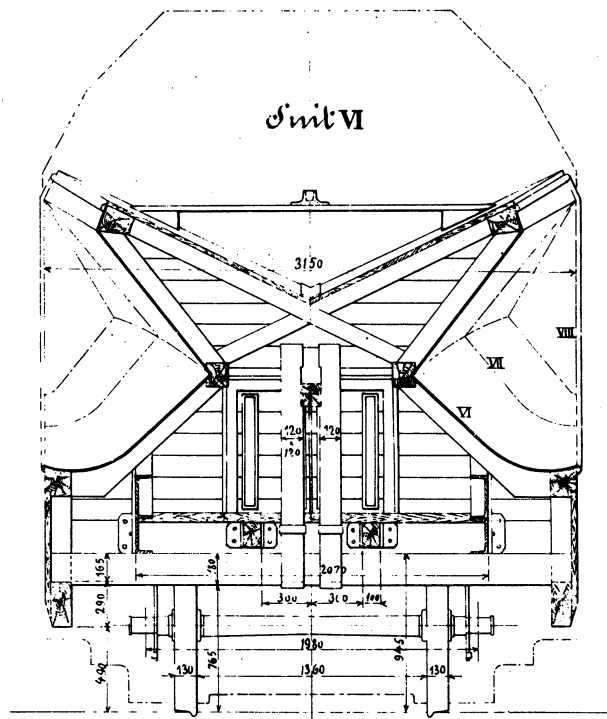

1:45

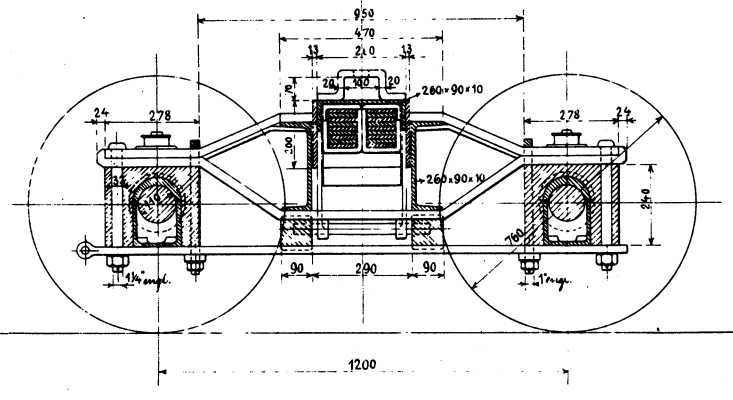
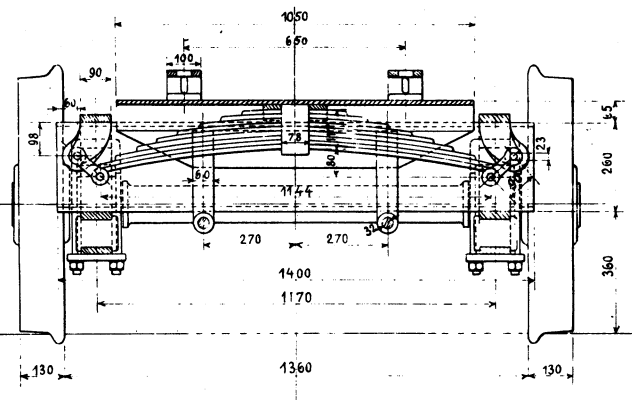
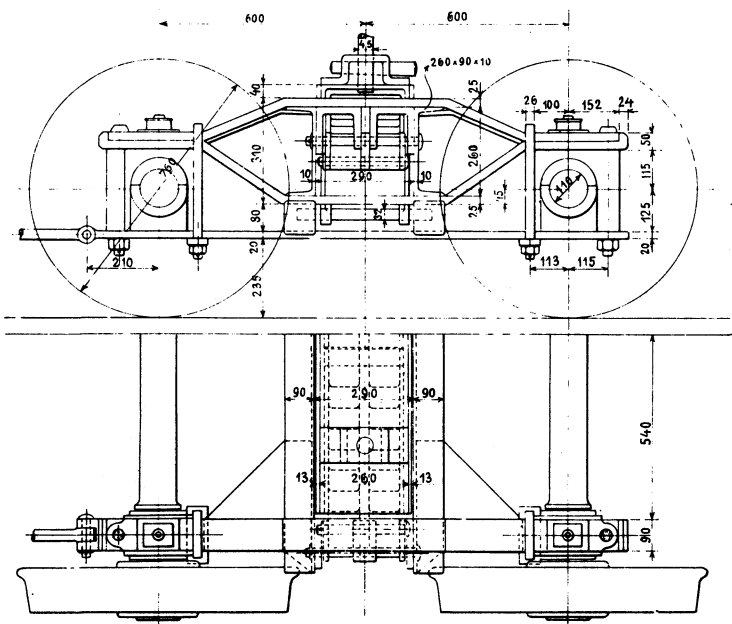

1:22,5

FFJ 2
AHB 3

AHJ 4
FFJ 5

