



HERCULES

*Operator's
Handbook*

DFX Series
Diesel

DFXB — 5" x 6"
DFXC — 5 $\frac{1}{4}$ " x 6"
DFXD — 5 $\frac{1}{2}$ " x 6"
DFXE — 5 $\frac{5}{8}$ " x 6"
DFXH — 5 $\frac{3}{4}$ " x 6"

SIX CYLINDER

HERCULES MOTORS CORPORATION

Canton, Ohio

U. S. A.

Top.	350.
Plat.	263
R.L.	260

HERCULES

Compression Ignition Injection
Engine
(Diesel Type)

Six Cylinder Diesel Engine of the DFX Series

JANUARY 18, 1950

HERCULES MOTORS CORPORATION

Canton



Ohio, U. S. A.

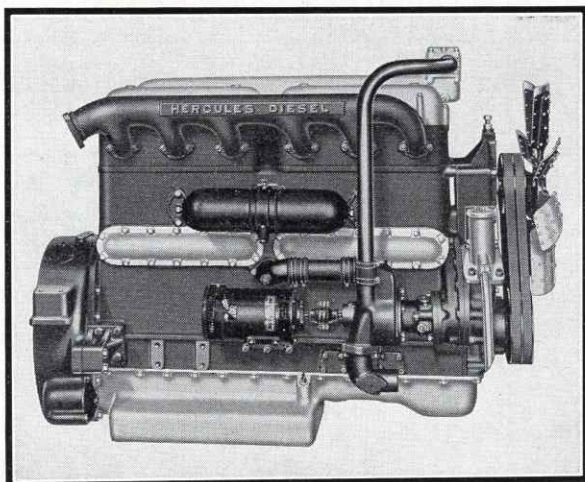

DFX Series Water Pump, Generator and
Oil Filter Side

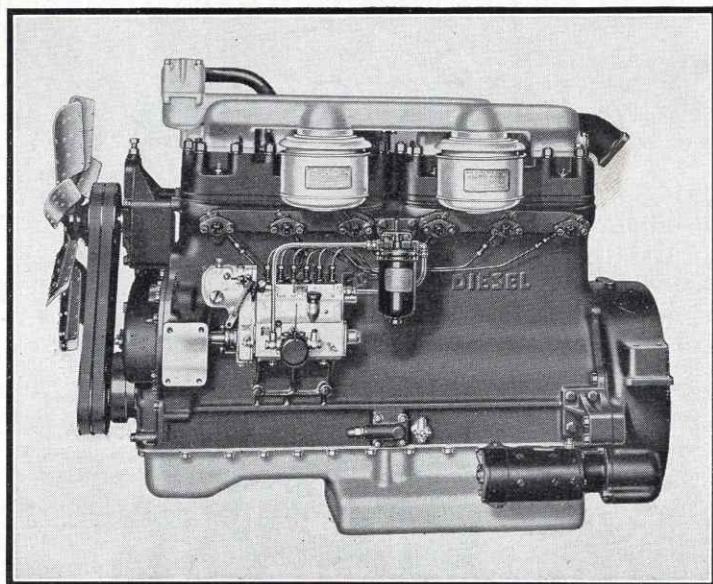

DFX Series Fuel Injection Pump Side

Introduction

THE Hercules compression ignition injection type engine is the result of years of development and field experience. Extensive tests have proved these different size engines adapted to all purposes for which such sizes and types are needed. The Hercules Motors Corporation was not satisfied to merely build an engine which would operate on the Diesel Cycle principle but this engine had to be of a type which would eliminate many of the objections to some of the existing compression ignition engines. These Hercules Diesel type engines have demonstrated their ability to operate smoothly and to be free from objectionable smoke while developing surprising power. It was essential that this type engine should demonstrate its fitness for a place in the Hercules line by giving the same satisfactory results which thousands of operators have obtained from several hundred thousand gasoline engines which have been manufactured by this company during the past thirty-one years.

The Hercules Diesel Series has been designed to follow as closely as possible the characteristic features of the Hercules gasoline engines wherever the design has not required the introduction of entirely new features because of the compression ignition principle of operation. This made possible the use of the valuable experience obtained from field operation of several hundred thousand Hercules Engines and these features not only assure satisfactory performance but they also enable the average mechanic to make adjustments in exactly the same manner as he has been accustomed to make them on the Hercules gasoline engines.

An effort has been made to give sufficient information to permit an experienced mechanic making the various adjustments and replacements which may be needed.

To men trained in compression ignition type engine operation the Hercules Diesel series present no maintenance problems and the construction of the Hercules compression ignition engine is so similar to that of the more common gasoline engine that no good mechanic need hesitate to make all of the ordinary adjustments.

The mystery commonly surrounding the Diesel cycle engine will be eliminated by careful study of the various parts of this book which covers design, construction and maintenance, but we do not wish to encourage any inexperienced person attempting to make repairs or adjustments, for such action may result in very expensive repairs being necessary. Do not attempt to start, operate or service a Hercules compression ignition engine without becoming familiar with the instructions given under these various sections.

Compression ignition engines have generally been called Diesel engines in the past due to their operating on the Diesel cycle. For the sake of brevity the Hercules compression ignition engine will be referred to in this book as a Diesel engine by which name it is most commonly known.

HERCULES MOTORS CORPORATION.

SPECIFICATIONS

Models DFXB DFXC DFXD DFXE DFXH Diesel Engines

	Model DFXB	Model DFXC	Model DFXD	Model DFXE	Model DFXH
Bore and Stroke	5"x6"— 127x152.4 M/M	5¼"x6" 133.3x152.4 M/M	5½"x6"— 139.7x152.4 M/M	5¾"x6"— 142.9x152.4 M/M	5¾"x6"— 146.1x152.4 M/M
No. of Cylinders	6	6	6	6	6
N. A. C. C. Horsepower	60	66.2	72.6	75.9	79.4
Piston Displacement	707 Cu. In. or 11.6 Litres	779 Cu. In. or 12.8 Litres	855 Cu. In. or 14 Litres	893 Cu. In. or 14.6 Litres	935 Cu. In. or 15.3 Litres

Rotation—Clockwise Standard, Looking at Cranking End. Anti-clockwise optional.

SPECIFICATIONS ALL MODELS

MAIN BEARINGS

No. of Bearings	7	
Bearings, Diameter	4½"	114.2 M/M
Bearings, Length (Front 1)	2¾"	60.3 M/M
Bearings, Length (Center 4)	3⅝"	92.1 M/M
Bearings, Length (Rear 7)	3"	76.2 M/M
Bearings, Length (Int. 2-3-5-6)	2"	50.8 M/M

CAMSHAFT

Drive		Helical Gear
No. of Bearings	8	
Dia. of All Bearings	2¾"	60.3 M/M
Length (Front 1)	2⅝"	53.2 M/M
Length (Center 4)	2¾"	69.8 M/M
Length (Int. and Rear 2-3-5-6-7)	1¾"	34.9 M/M

Location—Right Hand Side Looking at Flywheel

CONNECTING ROD

Material	Heat Treated Nickel Chrome Molybdenum Steel
Connecting Rod Bearings, Dia.	3⅝" 84.1 M/M
Connecting Rod Bearings, Lgth.	2½" 63.5 M/M
Connecting Rod Length, c to c	12" 304.8 M/M

GENERAL DATA

Fuel Pump	Plunger Type
Fuel Nozzles	Pintle Type
Fuel Transfer Pump	Integral with Fuel Pump
Fuel Strainer	Efficient Type
Governor	Mechanical Type
Air Cleaner	Efficient Oil Bath Type
Compressor, Provision for 4 to 12 cu. ft. Air Compressor (or Vacuum Pump)	
Exhaust Manifold Bore	¾"—82.5 M/M

On Right Hand Side, Looking at Flywheel.

NOTE: The Hercules Motors Corporation reserves the right to change design or specifications, without notice.

“DFX” Series

Prelude to Operation

The “DFX” Series Hercules Diesel Engine consists of five models, the “DFXB,” “DFXC,” “DFXD,” “DFXE,” and “DFXH” differing primarily in bore diameter. The remarks hereafter will refer to the series in general except where a definite model is discussed. This book covers the vertical type engine but nearly all remarks will apply to the horizontal or flat type with a few exceptions which are covered in section starting on page 86.

All information relative to operation and maintenance is the result of many contacts with a variety of operations of Hercules Diesel Engines and suggestions contained in different sections of this book are based on actual experience.

The book has been compiled for your use in obtaining the maximum efficiency and trouble free operation which has been built into your diesel engine by Hercules craftsmanship.

Should you have a particular problem not covered in this book, we invite you to write the Service Department, Hercules Motors Corporation, Canton, Ohio, U.S.A., whose experienced personnel will be pleased to assist you.

If additional information relative to the various accessories is desired, a letter to the manufacturers of these will always get a prompt reply.

PRECAUTIONS

READ BEFORE STARTING ENGINE

The following precautions, if followed, will help eliminate operating difficulties and abnormal wear:

1. **Filters**—keep them clean—they are the guardians of your engine—dirty filters cause rapid wear and low engine power output. Read section starting on page 57.
2. **Fuel Oil**—keep it clean—do not use dirty containers to handle it—insist on the fuel being clean and acid free when you get it. Procure it from reputable companies—See page 19 for specifications.
3. **Lubricating Oil**—keep it clean—drain crankcase often. Use best brands obtainable, regardless of cost, the best is none too good. Avoid oils having additives detrimental to alloy bearings. See section starting on page 15.
4. Do not allow **oil level** to fall much below the 4/4 mark on the bayonet gauge. As the lubricating oil is the medium for removing the friction heat in the bearings, the larger the volume, the more heat can be absorbed. On dry sump engines keep oil reservoir up to correct level at all times.
5. **Do not run engine** at any time without lubricating oil or cooling solution (water or anti-freeze mixture).
6. Do not use oil, fuel oil or kerosene in the cooling solution or as a cooling medium as these will be detrimental to the synthetic rubber water pump seal.
7. **Never run engine** with water or anti-freeze solution **boiling**. This allows lubrication to break down and may seriously damage engine.
8. Do not put cold water in an **overheated engine**. It may crack cylinder head, block, etc. An overheated engine shows negligence in operation.
9. Do not allow **air cleaners** to become clogged or to operate without all con-

- nections being tight. Keep clean oil in them up to the proper level. These units protect your engine from undue wear only when they are given intelligent care.
10. Never allow your **batteries** to run low or dry of water. The plates will warp and ruin the battery.
 11. **Do not attempt starting engine** until lubricating oil, water and fuel supply has been checked and the engine properly prepared for starting. See section starting on page 7.
 12. **Do not run engine** at high speed without load, as this will cause undue wear and shorten the engine's life.
 13. **Do not idle engine** for long periods as it is not only detrimental to the engine but also increases operating costs as you are using fuel without any benefit.
 14. **Do not use engine as a brake** in intermediate or low gear in automotive service. The high engine speeds possible when using low or intermediate gear descending steep grade will turn the engine much faster than the speed for which it is designed and damage will result unless vehicle speed is held to that used in same gears on the level.
 15. **Never allow engine to run without oil pressure** showing on the gauge or with viscosity so low the pointer is in the low register of the Visco Meter. Damage from lack of lubrication will result.
 16. Do not operate **fuel injection pump** with one or more line shut off or blocked. The high pressure may ruin the pump.
 17. Do not attempt to make repairs or adjustments to the fuel injection equipment unless you are familiar with it. It is far less expensive to take it to the nearest authorized service station.
 18. **Correct fuel nozzle pressure** is essential to efficient operation. Have nozzles checked often. See page 29.
 19. Do not allow fuel in tank to run low as it may allow fuel transfer pump line to uncover long enough to fill the lines with air and cause the engine to stop, resulting in lost time taken for repriming. See page 8 for more details.
 20. Loss of power, erratic running and poor performance often results from **air in the fuel injection system**. Be sure there are no leaks in fuel lines and filters which will allow this condition to exist. Vent cocks on top of filters are for bleeding off any air which may accumulate from bubbles in the fuel and very minor leaks, therefore it is essential to bleed these often until the operator is sure air is not entering the fuel system. For more details see page 8.
 21. Remember dirt, grit, water, lint or any foreign matter in both the fuel and lubricating oils is detrimental to the engine and it is your duty as an operator to see that it does not get into the engine.
 22. Do not attempt to start engine in cold weather until you have read section covering "**Cold Weather Starting**," page 9.
 23. Some external heat will help starting in cold weather and saves the batteries.
 24. Never run starting motor longer than 30 seconds at one time without a rest period of at least one minute before allowing it to run again. Failure to follow this procedure may result in a burnt out starting motor.
 25. **Altitude** affects engine starting and operation. Please read carefully section on page 14 devoted to this subject.

26. Diesel engines will run in either direction, therefore, it is essential that the engine should never be stalled on a grade where the reversed action of the vehicle will cause the engine to start backwards. Same also applies to other applications where stalling may cause engine to start backwards. When this happens, which is seldom, stop engine with stop control before damage can occur.
27. Do not attempt to start or operate this engine without first reading the instructions in this book carefully. As an operator you owe it to yourself.

STARTING AND OPERATING SUGGESTIONS

1. Procure a good brand of fuel oil coming up to the specifications of A.S.T.M. D-1 fuel oil as set forth on page 20.
2. Use only the best lubricating oil obtainable. See specifications on page 15.
3. An S.A.E. 30 oil is a good grade to start with, from this the proper grade can be determined by means of the Visco Meter. See page 16 for complete information relative to the function of the Visco Meter.
4. Fill cooling system with clean water (if in locality where water has a large percentage of dissolved minerals or is alkaline—use rain water). Allow sufficient time for water to seek lowest level, then complete filling.
5. If 24 volt batteries are not furnished with the unit, procure only those of a good brand and with the following capacity: 210 ampere hours (similar to 2 Exide 6XCK25-3R, 12 volt 25 plate or 2 Willard RHD-25-6, 12 volt 25 plate).
6. Be sure the batteries are hooked up properly before pressing the starter button.
7. Turn engine over three or four times by hand to be sure there is nothing sticking or water has not seeped into cylinder, as the starting motor has sufficient power to bend or break certain parts should anything be out of place.
8. Be sure all fuel line connections are tight and the fuel system properly primed.
9. Always follow starting instructions outlined below to eliminate difficulties.

STARTING THE ENGINE

Save Your Batteries. The two commonly used twenty-five plate 12 volt batteries will crank the engine against compression for about six periods of 30 seconds each with a recuperation or rest of one minute between each period of cranking. Hand cranking, or electric starter cranking with nozzle holders removed during tests for fuel oil delivery to nozzles will conserve the battery charge.

If the atmospheric air temperature is 50° F. or over the following instructions should enable anyone to readily start the engine. If air temperature is below 50° F. also read cold weather starting instructions, pages 9, 10 and 11.

First Time Engine Started or starting engine after a long period of shut down.

1. Fill the fuel tank with suitable fuel oil. See fuel specifications, page 20.
2. Fill cooling system with clean pure water or if atmosphere is below freezing and engine is to stand or operate in these temperatures, use anti-freeze solution.
3. Fill crankcase with suitable lubricating oil to the 4/4 or full mark on the oil gauge rod. If dry sump engine, fill reservoir to proper level. See lubricating oil specifications on page 15.

4. Leave nozzles out of engine while hand cranking to relieve compression.

5. Turn engine over by means of hand crank three or four times to start oil circulation and distribute the oil already on the surfaces. This hand cranking also prevents possibilities of damage due to water having accumulated in the cylinders. The clearance between the cylinder head and piston top is so little that a small amount of water in the cylinder would cause serious damage or wreckage if engine were rotated rapidly as with electric starter.

Priming Fuel System—Air Lock Trouble

6. Air or gas binding or lock in the fuel injection system is the most general cause of failure to start or hard starting if proper fuel is used. Air binding or lock is caused mainly from leaky fuel lines, check valves, or running out of fuel. Gas binding or lock is caused by heating of the fuel to a point higher than that at which the particular fuel used begins to throw off gaseous vapors. To eliminate either of these difficulties the following procedure should be followed:

Loosen the check valve fitting and by using the hand priming pump pull the fuel from the tank and force it through the filter located between the transfer pump and the injection pump. It is best to leave vent cock No. 1 in Illustration No. 24 open until all the air is out of the system up to this point, then close vent cock and pump fuel into the injection pump until a solid stream of oil comes through the opening created by loosening the check valve fitting. Then tighten this connection.

(a) Place governor control lever in wide open or full load position.

(b) Be sure stop control is not in shut off position.

(c) Install nozzle holders firmly in place, if these were removed for any reason.

(d) Loosen fuel line nut at the nozzle holder end.

(e) Remove side cover (inspection plate) or plug of fuel pump.

(f) Work the fuel pump plunger up and down by means of a screwdriver until clear fuel with no air bubbles flows freely, then tighten nut, see illustration No. 4. Continue the same operation with all six lines being sure the stop control rod is not in "shut off" position.

(g) Replace side cover (inspection plate) on fuel pump. Any time this fuel pump inspection cover is removed for any purpose great care must be exercised to insure its proper replacement as well as to insure against any dirt getting into the fuel pump.

7. In addition to the procedure just described check the lubrication of fuel injection pump, generator, starter, governor, air compressor or vacuum pump (if used), fan, water pump, and any other accessories. Check air cleaners to make sure there are no obstructions, that they are properly installed, and are clean, and that they are properly filled with oil (if oil bath cleaners are used as recommended).

8. Check entire electrical system to be sure there are no loose connections and all component parts are properly connected together.

9. See that no loose bars, tools, parts, etc., are laying in or on any part of the engine as they could cause serious damage or wreckage of engine or bodily injury to anyone near.

COLD WEATHER STARTING

10. Start engine by operating the starting button. If atmospheric temperature is 50° F. or above, and if all of the foregoing instructions have been properly followed and the proper grade and type of fuel oil has been used, the engine will start at once.

11. Allow engine to run for several minutes before load is applied to enable engine to properly warm up and insure proper lubrication. See pages 11 and 12 for instructions when engine is started.

Usual Routine Way of Starting Engine. If the engine has been operating recently and nothing has been removed or repaired since it last operated, the following is all that is necessary to start:

1. Check fuel supply.
2. Check lubricating oil in engine base with gauge rod. Be sure oil is to 4.4 or full mark on rod. If dry sump, to proper level in reservoir.
3. Check cooling water.
4. If atmospheric temperature is 50° F. or above nothing special need be done in preparation for starting. If below this temperature see "Cold Weather Starting."
5. Inspect installation to see all is in good order and tight and no loose tools, bars, or parts are laying on engine.
6. Start engine by operating starter button.
7. Check engine as under "Operating Instructions After Starting," pages 11 and 12.

COLD WEATHER STARTING

The increased temperature of the air due to compression is the only means of igniting the fuel sprayed into combustion chamber.

If the iron surrounding this chamber and cylinder is extremely cold and in addition the air entering the cylinder before compression is cold, the resultant temperature may not be sufficient to ignite the mist of fuel. The faster the starter turns the engine the less time is available for the heat of compression to be absorbed by the iron and water.

Two methods are available to increase this temperature.

1. Heat the water or cooling solution.
2. Heat the air before it reaches the cylinder.

One or both of the methods may be necessary, depending upon temperatures of engine and air.

A heating device is available which makes starting easier in extremely cold weather or climate. This device can only be installed by an authorized service station or by the Hercules Motors Corporation.

Starting Between 50° F. and 32° F. If engines are not equipped with an air intake heater assembly much time can be saved and excessive drain on starting battery and can be avoided by following these suggestions:

1. Crank engine over by hand several turns.
2. Remove large pipe plug in intake manifold, or remove air cleaning equipment if no pipe plug is available.
3. Before attempting to start, take an ordinary blow torch and direct the flame for a minute on the outside of each branch of the air intake manifold of cylinder head.
4. Put fuel control lever in wide open position.
5. Just as the operator closes the starter button direct the flame into the intake manifold inlet exposed by removal of air cleaner or pipe plug.

6. After engine has started replace pipe plug in manifold or replace the air cleaner, whichever was removed.

Starting Between 32° F. and 0° F. If engines are not equipped with an air intake heater assembly. To obtain maximum cranking speed the oil must not be too heavy. Many experienced operators drain all crankcase oil from engine at end of day's run and heat it before returning it to crankcase when ready to start, when temperatures approach freezing. This is a good practice for the hot oil insures more immediate circulation to the bearings and helps warm the engine. At freezing temperatures, the water or cooling solution should be drained from engine and radiator and heated to near boiling point if water, and as hot as possible if solution is used. (Beware of fire if alcohol solution is used.) When this is poured into engine the cold iron parts are heated and oil on cylinders thinned down. Most cooling systems hold about 25 gallons so an oil drum or wash tub can be satisfactorily used. This operation does not take nearly as long as changing batteries after they are run down and will greatly aid in starting

Use nothing but pure mineral base oil. No compounded oils having animal or vegetable matter.

Starting 0° F. and below. If engines are not equipped with an intake heater assembly, the heating of water, oil and air may be found desirable. Battery output is reduced at these low temperatures so every means should be used to conserve your battery.

Air Intake Heater. Some engines are equipped with a device built into the inlet manifold, called the "Air Intake Heater." It consists of a small hand operated pump located at the engine controls which pumps fuel oil through an oil burner nozzle, using 3/16 inch or smaller O. D. tubing. The nozzle is located inside the inlet manifold. It directs the spray of fuel oil through the length of the inlet manifold. The housing containing the nozzle also contains a spark plug with a very log electrode, and also a continuous vibrating spark coil suitable for 24 volt operation. A grounded electrode is adjusted with its end approximately 1/8 inch from the spark plug's electrode, for a spark jump of about 1/8 inch. This spark is in front of the fuel spray and ignites it as it emerges from the nozzle. The spark is continuous from the vibrating coil. A pressure switch is connected in the fuel line coming from the hand pump. When there is a spray of fuel coming from the nozzle, there is pressure on the switch which closes it and starts the spark to ignite the fuel spray.

The flame of the burning fuel is sucked into the engine as it is being cranked, and warms the air in the cylinders for cold starting. Of course, some of the "air" in the cylinders is only the burned gas from the flame because all the flame goes into the cylinders, and if the flame burns all the oxygen in the air going into the cylinders, there is none left to burn the fuel sprayed into the combustion chamber by the injection pump and the engine cannot start. Therefore, too much flame is just as bad as none at all for cold starting. It is necessary to give the engine some flame, but not too much, which is done by pumping one stroke of the hand pump while cranking, then wait a few seconds before giving another stroke. Don't pump any more than absolutely necessary. When the firing of the cylinders slows down while pumping, stop pumping and if the engine slows down after pumping is stopped, give the pump another short stroke. Two or three strokes usually are sufficient to start engine in freezing weather. Be sure engine is being cranked before operating the priming pump.

OPERATING INSTRUCTIONS AFTER STARTING

To determine that the inlet air heater is working, remove the pipe fittings in the center of the inlet manifold. Give the priming pump one stroke while cranking the engine. Flame should come out of the open hole. **DANGER** — Keep away from this hole, a flame coming out may cause serious injuries. If the hand pump cannot be operated in the discharge direction, it is evidenced the screen of the nozzle is pluggd up. It may be removed for cleaning or replacing by taking the heater assembly off the engine. If the fuel spray is O. K., but will not ignite, check the pressure switch by removing the wires leading to it from the battery, and hold it against the other terminal while cranking the engine and operating the priming pump. If the fuel spray still does not ignite, remove the heater housing and clean the spark plug, readjust the spark gap, and observe the spark. If there is none, check for a short in the wiring and listen for the buzzing of the vibrator in the end of the coil. The vibrator points may need cleaning or replacing.

OPERATING INSTRUCTIONS AFTER STARTING

After the engine has started an inspection of the whole engine unit should be made to make sure all parts are functioning properly.

(1) Look at lubricating oil gauge. If no pressure shows after engine has run 10 or 12 seconds shut down the engine and ascertain what the trouble may be. With bearings in good condition and proper grade of oil, the pressure should be 30 to 45 pounds at full engine speed. If the oil is very cold or heavy this pressure may be much higher. As the oil heats up the pressure will reduce.

(2) Check water circulation. If no water is flowing, shut down engine and ascertain what the trouble may be. Never operate with the water boiling as this heat on the cylinder walls breaks down the oil film and also causes considerable water loss due to steaming.

(3) See that no loose tools or parts are laying on or near the unit as they might fall into a place where they would cause damage or personal injury.

(4) Observe engine operation for smoothness, quietness and exhaust condition. If the fuel is up to specifications and has the proper ignition and burning qualities, the engine may still run raggedly because a cylinder or two is firing irregularly due to being cold. As the engine begins to warm up however all cylinders should fire regularly. If they do not, the nut connecting the fuel line to the nozzle holder should be slightly loosened one cylinder at a time and fuel allowed to flow until all air has been expelled. When this nut is loosened, if the engine speed remains the same and the exhaust sounds the same, that cylinder is not firing or is firing irregularly. If after checking this trouble and allowing fuel to flow from the loosened nut a few times any cylinder still continues to fire irregularly or not at all, shut down the engine and trace out the trouble, some hints of which will be found on pages 80 and 81.

(5) See that there is an adequate supply of fuel in the tank and that fuel is being delivered to the fuel pump. The delivery can be checked by slightly loosening the nut connecting the supply pipe to the fuel strainer and if a good quantity of fuel appears it is an indication that the fuel injection pump is being supplied with sufficient fuel. If no fuel or very little appears, shut down the engine and check the supply tank again. If the fuel supply is adequate, check fuel lines from tank to transfer pump and transfer pump to strainers for leaks from loose connections, broken nuts, and cracked or broken lines. Also check lines for obstructions inside or having been pinched closed or nearly so. If lines are found satisfactory, check transfer pump for broken

springs, worn or broken valves or plungers or worn or stuck tappet rollers, followers or wrist pins.

(6) Observe Visco Meter for viscosity of lubricating oil. If needle on gauge is in the high section allow engine to run idle until the indicating needle shows the oil is of proper viscosity to insure safe engine operation. If indicating needle drops into the lowest section, stop engine and check trouble. Starting with Viscometer Instrument screen, illustration No. 1, clean if necessary. It may be necessary to change oil in engine sump. It may be that oil being used is not of proper grade or quality or quantity or has not been changed recently enough. This Visco Meter is the indicator of the lubricating qualities of the oil lubricating the engine and should be observed often. This instrument should receive attention, as outlined in section starting on page 16, frequently as it is the most useful instrument on the engine. Go by what the needle indicates and give the gauge and instrument good care as it will repay you many times over.

(7) Check and see that there are no oil or water leaks.

(8) Clean lubricating oil filter often. This will insure maximum efficiency from this unit and does not require much time or energy to accomplish.

(9) Keep all fuel filters clean and give them regular attention. This will eliminate many costly fuel injection pump and nozzle troubles.

(10) Observe fan and belt operation. Loose fan belts allow slippage which reduces the efficiency of the fan and wears belts out rapidly. Never allow fan to run without any lubricant but do not over-lubricate as it will throw off the excess on the surrounding parts.

(11) See that the radiator, if one is used, is free of obstructions between fins or tubes as they will obstruct air flow and reduce the cooling efficiency of the radiator unit.

STOPPING THE ENGINE

1. Stopping is generally effected by pulling the stop control out until engine stops.

2. If atmospheric temperature is below freezing and no anti-freeze solution is used, the complete water circulating system should be drained. This includes engine water jackets, water pump, radiator if used, and all water pipes.

3. If anti-freeze solution is used the solution should be checked with a hydrometer to make sure the solution will not freeze. It is best to have a solution that will not freeze at temperatures far below those then being experienced.

4. Do not fill batteries with water when shutting down as this makes them more liable to freezing. Fill batteries just before starting up for the day's run.

NOTE: If engine is kept in a warm storage or is located in a warmed building where freezing is not liable, 2, 3 and 4 can be disregarded.

STORING ENGINE FOR LONG PERIODS

If engine is to be idle for a month or more, special preparations should be made to properly prepare the engine so that rust will not form on the wearing surfaces or in the fuel system.

Preparing Fuel Injection Pumps and Nozzles. Just before the engine is shut down for the last time, heat approximately two quarts of lubricating oil of

STORING ENGINE

same quality as used in the crankcase to about 180° to 200° F. This is to reduce the viscosity—the thickness—of the oil so it will flow through the fuel lines. Shut down the engine and disconnect the fuel line from the main tank to the transfer pump. Then place the hot lubricating oil in a container which can be located so the end of the fuel line which has been disconnected from the supply tank can be inserted in the container. Start engine and allow to run until practically all of the oil in the container has been taken into the engine, then shut down engine.

Another method to accomplish the same result is after the engine has been shut down to attach the two or three quart tank pouring about 2 quarts of this heated lubricating oil into it, disconnect the suction line from the tank to the transfer pump either at the pump or at the tank so when the engine is started fuel from the main tank will not be pumped all over the surrounding equipment. Start engine and allow to run until most of the oil in the small tank has passed into the fuel pump. Then shut down engine.

After engine is shut down, tape a small piece of gasket material over the breather hole on the fuel injection pump cover or inspection plate. Fill the fuel pump FULL of good quality acid and moisture free lubricating oil, through the fuel pump oil filler hole. Fill the pump until oil flows out of this oil gauge hole and then replace cover. This procedure will fill the pump housing with oil, protecting the fuel pump camshaft, tappet assemblies, etc.

When engine is shut down after either method of filling the fuel system, remove all of the fuel or spray nozzle holders. Remove the fuel nozzle body from the nozzle holder and then remove the valve from the body. Put a coating of vaseline on the valve and return valve to body, then cover the outside of the body with vaseline. Reassemble body and holder.

Preparing Engine. Before reinstalling the nozzles and holders back in their place take a pump type oil can with a long narrow spout with a tip that will fit into the 7/32" or larger hole of the spray nozzle sleeve, and give it six or eight squirts per cylinder, then turn engine over slowly a few times to distribute the oil.

BEFORE STARTING remove spray nozzles and turn engine over with starting motor to blow excess oil out.

Drain the entire engine and water circulating system thoroughly.

Leave the lubricating oil in the engine base.

Disconnect the wires leading to the batteries and remove the batteries, storing them preferably at some place where they can be charged periodically, as batteries lose their charge rapidly if not in use.

Cover ends of air inlet and exhaust pipe so moisture cannot reach valve ports and cylinders; store the engine where it will not be exposed to the elements such as sun, rain, snow, hail, etc., and preferably where it can be kept warm and dry.

Every two weeks the engine should be cranked over by hand eight or ten revolutions to redistribute the oil film over the wearing surfaces. This will prevent rusting of the wearing surfaces inside of the engine.

As the fuel injection pump and nozzle assemblies are built to such close limits they require very close attention when storing with the engine. American Bosch have a special oil to put into these units when storing and a very good plan is to get in touch with the nearest American Bosch Diesel Service Station and obtain full information on how they store the fuel pumps and nozzles using this special oil.

If this is done it will not be necessary to fill the fuel transfer and injection pump, fuel lines and nozzles as just described under "Preparing Fuel Injection Pump and Nozzles." The engine proper however must be properly prepared and the rest of the procedure given should be followed.

Preparing Engine For Starting After Long Shutdown. If engine has been stored as given in the previous chapter it will be necessary to pursue the following procedure to prepare it for starting again:

1. Drain entire fuel system of lubricating or special oil. Open the drain on the bottom of the main fuel supply tank and allow all water and sediment in tank to drain, then reconnect the tube.

2. Check all fuel supply lines from main supply tank to fuel filter to make sure connections are tight and lines are open with no obstruction or "pinched" places.

3. Remove nozzle holders and wipe vaseline from outside surface of each nozzle. Do not wipe the vaseline off the valve in the valve body. Prime pumps and lines as described on page 8.

4. When priming the fuel lines from pump to nozzles connect the nozzles to the fuel lines and test as described on page 28 except instead of running the engine operate the pump plunger by hand.

5. If nozzles do not function properly clean as described on pages 27 and 28.

6. Turn engine by hand three or four revolutions to spread the lubricating oil on the walls and bearings and start oil circulation.

7. Install fuel or spray nozzles and connect lines tightly.

8. Drain lubricating oil filtrator of all water and sediment.

9. Fill cooling system with clean water or anti-freeze solution.

10. Follow instructions as given for "Starting Engine First Time," described on page 7.

11. After engine is running follow instructions as given for "Operating Instructions After Engine Is Started," described on pages 11 and 12.

ALTITUDE OPERATION

The starting and operation of Diesel engines encounters certain difficulties at higher altitudes. These difficulties are not commonly noticeable until 3000 feet is reached. Above this altitude it is necessary to make certain changes in the engine to facilitate starting, to increase power output and to eliminate incomplete combustion; these will be taken up separately in paragraphs to follow:

While the engine has lost only about ten percent at 3000 feet, at 6000 feet this loss is about 21%. From these figures one can readily see that no difficulty will be encountered in the first 3000 feet but that some provision should be made to help eliminate or overcome part of the power loss and hard starting. A small part of this loss may be recovered by the following methods.

Due to the air at higher altitudes being lighter the cylinders do not fill as well as at sea level, therefore the compression pressures are lower, causing harder starting and poor combustion. This can be helped by changing the combustion chamber liners so as to get a higher compression of the lighter air entering the cylinders.

Since the air is lighter, a longer period is required to effectively burn the fuel oil, the injection pump timing should be advanced about 1° per 1000 feet

over the standard timing, unless the compression ratio is increased, in which case the timing can remain the same as originally set. This will help starting and combustion, resulting in a little better power.

It is also necessary to reduce the amount of fuel entering the cylinder as with the original setting and smaller amount of oxygen the combustion is incomplete and a smoky exhaust results.

It is sometimes desirable to follow the starting methods as outlined under "Cold Weather Starting" on page 9.

A starting device is available which makes starting easier in extremely cold weather or climate. This device can only be installed by an authorized fuel injection pump service station or by the Hercules Motors Corporation.

For additional information on specific cases please write to Service Department, Hercules Motors Corporation, Canton, Ohio, U. S. A., giving as much data as available.

LUBRICATING OIL AND VISCOMETER

Lubricating Oil. The Hercules Motors Corporation recommends that only the best quality oils manufactured by recognized concerns familiar with the lubrication requirements of Diesel engines be used. Uncompounded naphthenic oils or certain mixtures of naphtha and paraffin oils have in many instances given good service providing the film strength is equal to paraffin oils. Many refiners now advocate the use of compounded oils for high output Diesel engine lubrication. These various products which are secured by combining an additive with different base stocks are somewhat secret in their composition and, therefore, the refiners must be held responsible for proper recommendation as well as results obtained from their use. In general we suggest the use of compounded oils. The common gasoline engine oils are not generally suitable for use in Diesel engines. All corrosive types of lubricants must be avoided. Natural or added compounds of proved stability and merit are satisfactory but additives must not be destructive to alloy bearings or promote the formation of acid, alkaline and sludge.

If the sales divisions of these refiners cannot give you reliable first hand information about their compounded oils then present your problem to the technical divisions of these same refiners. The Hercules Motors Corporation cannot assume any responsibility for engine failures due to the use of incorrect lubricants in their Diesel engines.

Due to the differences in viscosity of different brands of oil at the same temperatures and the difference in crankcase temperature in engines on different types of service it is difficult to give a definite SAE number of oil to use in the engine crankcase. A Visco Meter instrument shown in Illustrations No. 1 and 2 is frequently supplied to indicate the viscosity of the lubricating oil during the actual operation of the engine and this gauge should be used when possible in determining what grade of lubricating oil to use.

For most operations a pure, neutral acid and moisture free, petroleum oil with no animal or vegetable matter of an SAE 30 grade will be found satisfactory and should be obtained for trial. Do not obtain a large supply of any lubricating oil until a grade and brand suitable for the particular service the engine is to operate under has been proved. This may vary with the seasons of the year.

Try such an oil in the engine under normal working conditions. If the indicator hand on the Visco Meter gauge dial moves to the left into the "low" or "stop" section, any time after the engine crankcase oil is at maximum operating temperature, the oil is too light and a heavier grade should be tried. If the indicator hand does not get within 3 graduations on the dial, of the "low" or "stop" segment, the oil is too heavy and a lighter grade should be tried. Read the instructions for selecting oil by use of the Visco Meter carefully.

In some very extreme cold operating conditions it may be necessary to use an ice machine oil to prevent oil from congealing while the engine is stopped for long periods, thus preventing valves from closing when trying to start and increasing the cranking friction so that the starting motor and battery do not have sufficient power to accomplish a start. Use a medium grade ice machine oil, after engine is restarted watch Visco Meter gauge. It is best practice, however, to warm the engine up before trying to start it by heating the oil or the cooling solution so that a standard lubricant can be used and eliminate the use of ice machine oil. **Do not put kerosene** in the lubricating oil to thin it out or prevent it from "freezing."

The length of time between draining and refilling with new oil is dependent upon the type of service and operation, and the grade and brand of oil used. Most operators find it wise to drain the oil every 50 or 60 hours of industrial operation and not over 1,000 miles of automotive operation (highway hauling trucks and busses, not tractors or heavy duty slow trucks such as snow plows, etc., the latter the same as industrial operation). See page 77 for refilling instructions.

Some lubricating oils under certain operating conditions develop serious sludge and gumming problems. Avoid oils which are not free of gum or wax.

Avoid use of oils which have additives detrimental to alloy bearings.

Visco Meter. Some engines are equipped with a Visco Meter instrument that indicates the viscosity of the oil just before entering the main bearings. The instrument is located on a pad on the engine crankcase.

Refer to illustration No. 1 which is a schematic assembly of the instrument and gauge. Follow the arrows which show the direction of the oil flow.

Some of the lubricating oil is led from the main oil header in the engine through a short copper tube shown as "oil supply" to the instrument and enters the instrument through an orifice into a filter screen. It passes through the screen into an automatic controlled chamber which has an orifice on one side and a spring loaded check valve called an "automatic unloading valve" at the other. The oil may enter the instrument at any pressure but this check valve is permanently set at a pressure low enough so the oil in the chamber is under a constant even pressure regardless of engine pressure unless the engine pressure becomes less than the setting of the unloading spring. The excess oil flows past the check valve and spills back into the engine crankcase. The rest of the oil passes through the orifice on the other side of this chamber into a passage which connects with the resistance tube. The other end of the resistance tube connects with the engine crankcase so some of the oil passes through this resistance tube and spills into the engine crankcase. This resistance tube is purposely restricted in size to restrict the flow of oil through it and thereby set up a pressure in the gauge tube line. Part of the oil therefore is under a pressure determined by the rate of flow of oil through the resistance tube and this is registered on the gauge dial by the indicator hand.

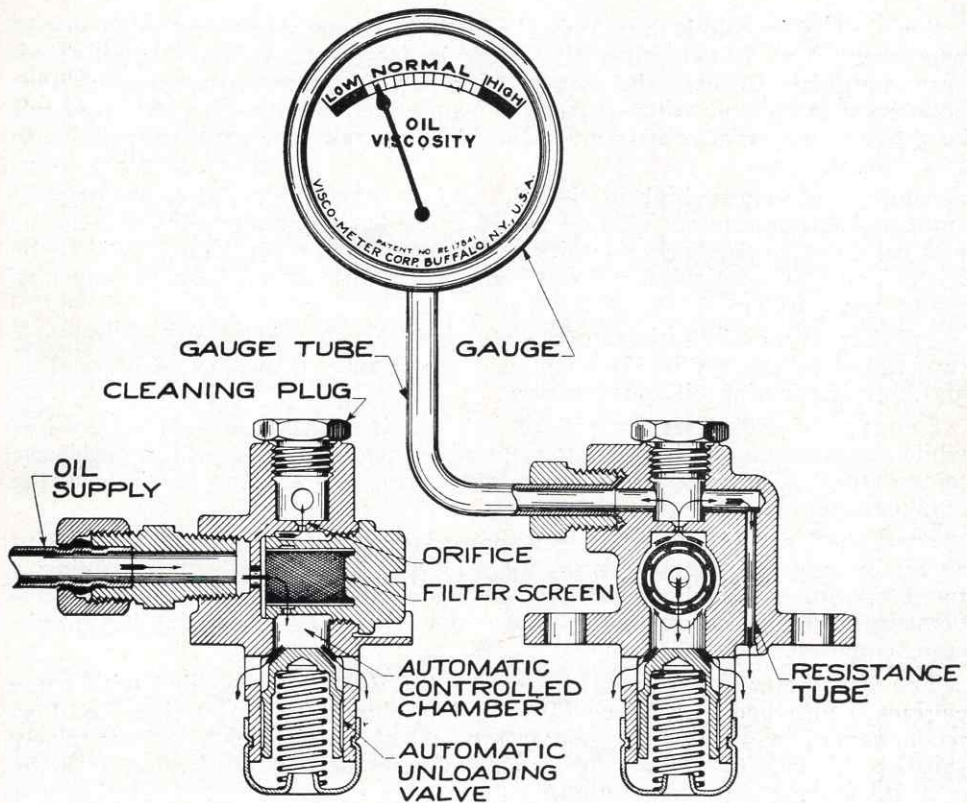

Illustration No. 1

As thick oil will not flow as rapidly through the resistance tube as thin oil under the same pressure, the indicator hand registers higher with the thick oil as the pressure in the gauge line is higher. The thinner the oil the less the pressure in the gauge line as there is less resistance to the flow through the resistance tube, and the lower the gauge reading.

Selecting Oil by Means of the Visco Meter. Pressure is no indication of the lubricating value of any lubricating oil. Pressure merely shows some kind of fluid is flowing through the system whether this fluid be water, fuel or anything else. Any fluid can be regulated in pressure so it will show exactly the right pressure on the pressure gauge and still not assure satisfactory lubrication. High pressure does not indicate better lubrication than the lowest pressure which still keeps an oil film on the metal surfaces as the object of the pressure is to keep the metal surfaces covered and any more will not assist in any way.

Pressure gauges do not therefore indicate whether the engine is being properly lubricated or not, they only show that the oil is flowing, and the lubricating qualities of the oil in the engine AT CRANKCASE TEMPERATURE must be assumed. Assuming the lubricating quality of an oil is not a very safe practice because of the variations in oil and engine operations and demands.

Some oil when cold is extremely thick—high in viscosity—and the same oil when heated up is extremely thin—low in viscosity. When thick it flows very sluggishly through the system with high registered pressure but very poor lubrication and when heated to engine temperature is thin, will not keep the metal surfaces apart and the engine scores, seizes or abnormal wear takes place.

Another oil may be high in viscosity at low temperatures and just right at crankcase temperatures. This oil would cause hard starting when the engine was cold, due to the high viscosity at low temperature causing the oil to be sticky and thick which would put quite an additional load on the starting motor and battery.

Another oil may be satisfactory when cold but when at operating temperature would be too low in viscosity, causing troubles from lack of lubrication and high lubricating oil consumption.

One type of engine service will keep the engine crankcase temperature low while the same engine in another type of service may have a high crankcase temperature. The change in temperature during the seasons also affects the crankcase temperature to some extent.

From the foregoing it can be seen that it is practically impossible to specify an oil by physical characteristics for all types of service without giving a range the top of which would not be satisfactory with cool crankcase temperatures and the lowest of which would not be satisfactory for hot crankcase temperatures.

The viscometer instrument Illustration No. 2 as now supplied with some engines if attached to a Visco Meter gauge shown in Illustration No. 1 as recommended will allow the operator to select an oil which is particularly suited to his type of service and which will give the best lubrication with the least lubricating oil consumption.

To select the proper oil obtain an oil which comes within the lubricating oil physical specifications and try in the engine. Start the engine and observe the indicating hand on the Visco Meter gauge. A proper oil should first move the indicating hand to the right close to or into the "high" section on the dial when oil is cold. As the oil warms up the hand should move to the left gradually until it reaches a position approximately as shown in Illustration No. 1 which is almost to the "low" or "stop" line on the gauge when the oil is at normal crankcase temperature. The oil should stay at the viscosity represented by this location of the indicator hand as long as the engine is operating. If this hand drops from this location it indicates the viscosity has dropped—oil has thinned—to a point of danger and the engine should be stopped immediately and oil changed to another brand or heavier grade until a suitable oil is found. Be sure Visco Meter Instrument is clean.

If, after the engine is operating and the crankcase temperature has raised to maximum, the indicating hand does not drop into a position somewhere in the last three graduations above the "low" or "stop" line on the gauge the oil is too heavy and should be changed to another brand or lighter grade.

Do not select lubricating oil because it has certain SAE number as certain brands of oil of SAE 30 may not have the lubricating characteristics necessary for your type of service but another brand of SAE 30 may, due to one being different at the top extreme limit and the other at the lowest extreme limit or at different points between these extremes. One brand of SAE 20 may give the same satisfactory results as another brand of SAE 30 or with another

brand, SAE 40 may be necessary—Always select the grade of lubricating oil by its operation in the engine, in the type of service to be encountered, by the Visco Meter and not by the price or physical characteristics or SAE number. The indicator hand shows how thick or thin the oil is in the engine at all temperatures and the grade of lubricating oil should be selected by what this hand indicates.

The lubricating oil pressure may be anywhere between 10 pounds and 45 pounds when the engine is at normal operating temperature depending on the speed. When the engine idles at reduced speed and the crankcase is at normal operating temperature the pressure may reduce to 1 pound and still have safe lubrication. Due to the extremely low pressure at reduced idling speeds the Visco Meter indicator hand may drop into the “low” or “stop” section but this can be disregarded and safe lubrication assured if the indicating hand goes back to its normal position when the engine is back at full speed again.

Care of Visco Meter. The Visco Meter should receive proper care and attention.

The whole instrument should be cleaned periodically. The time depends upon the oil used as some oils gum or plug up passages more quickly than other oils. To clean, remove the instrument from the engine crankcase by removing the oil lead lines from the crankcase and to the gauge.

Remove the two capscrews which hold the instrument to the engine crankcase. Remove the plug No. 1, Illustration No. 2, which holds the filter screen No. 2 and remove screen and clean thoroughly in clean fuel oil, gasoline or kerosene. Also wash out plug. Remove “cleaning” plug over the chamber connecting with the resistance tube. (See illustration No. 1.) Wash and soak the whole body in clean fuel oil, gasoline or kerosene so all carbon, etc., becomes loosened. If compressed air is available blow out all chambers and the resistance tube, making sure all are perfectly clean. If compressed air is not available obtain a pipe cleaner or wood dowel which will go through the resistance tube easily. Work this up and down in the tube from the unloading valve end until the tube is clean. Then wash the whole body thoroughly again in clean fuel oil, gasoline or kerosene, paying particular attention to the resistance tube. Remove and wash both oil lines. Reassemble the parts and install instrument on engine and connect removed oil lines.

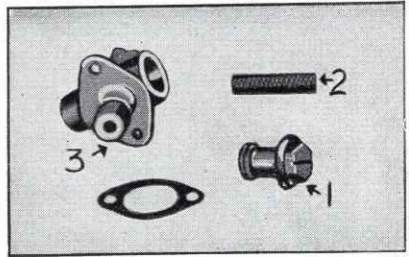

Illustration No. 2

The Filter Screen Should be Cleaned at Least Every Time the Crankcase Oil is Changed.

Never use anything except compressed air or PIPE CLEANER OR WOOD DOWEL to clean resistance tube as this is drilled to definite size and hard wire or drills are liable to ream or scratch this tube to a larger size and destroy the operation of the whole Visco Meter as the springs and gauge are calibrated for this original resistance tube.

FUEL OIL SPECIFICATIONS

American Society for Testing Materials Specifications

Fuel Oil Specifications. To be a chemically neutral distillate petroleum fuel oil of the following characteristics:

1. Viscosity at 100° F. Minimum 33 sec.
Saybolt Universal (Preferably 40 to 70) Maximum 100 sec.
2. Sulphur (By Weight) Maximum 1.5%
3. Conradson Carbon Residue (% by weight) Maximum .2%
4. Ash Content Maximum .02%
5. Moisture and Sediment (B.S.&W.) (% by volume) ..Maximum .05%
6. Flash (For insurance purposes only) Minimum 150° F.
7. Pour point at least 10° less than lowest temperature where engine operates.
8. Ignition and burning qualities to be equal to:
A.S.T.M. Grade No. 1-D
Cetane number, min.45

9. The "gum" content in the fuel oil is not to exceed 75 milligrams per 1000 cc's of fuel as determined by the "burn-out" test as follows:
Put 1000 cc's (approximately one quart) of the fuel in an enameled steel pan such as an ordinary wash basin. Set the pan at an angle of about three or four degrees. Ignite the fuel by the aid of three or four teaspoonfuls of gasoline and allow to burn out completely. Keep the pan in a place free from draft.

At the completion of burning, the gum content is the tarry residue remaining in the bottom of the pan unburned. This amount should not exceed 75 milligrams as determined by brushing away all loose dry carbon soot, then dissolve the tarry gum residue with benzene and filter. Distill off the benzene and weigh the remaining residue.

If convenient methods of weighing this "gum" are not available, the maximum permissible quantity of "gum" without causing excessive ring sticking can be observed in the bottom of the pan as not exceeding an area of approximately 1" in diameter and 1/4" thick.

NOTE: Recracked or recycled fuel oils are usually not satisfactory.

Fuel oil that has been "recracked" or "recycled" at the refineries is usually a hard oil to ignite. The ignitability of fuel oil cannot be determined by the usual characteristics of physical state of oil such as gravity, viscosity or color, all of which have no influence whatever on the ignitability of oil. Refineries and oil distributing agencies should assume the responsibility of supplying a fuel oil of good ignition and burning qualities. They can determine the ignitability of their fuel oil by methods recommended by A. S. T. M.

FUEL INJECTION EQUIPMENT

For Governor Information See Page 30 and Page 45

DESCRIPTION (Bosch):

The fuel injection equipment consists of an injection pump which is equipped with a fuel transfer or supply pump mounted on the side of the lower part of the injection pump case; a governor mounted on the end of the injection pump; a check valve to maintain a constant pressure in the fuel manifold; six fuel lines; six nozzles and a leak off manifold.

FUEL INJECTION EQUIPMENT

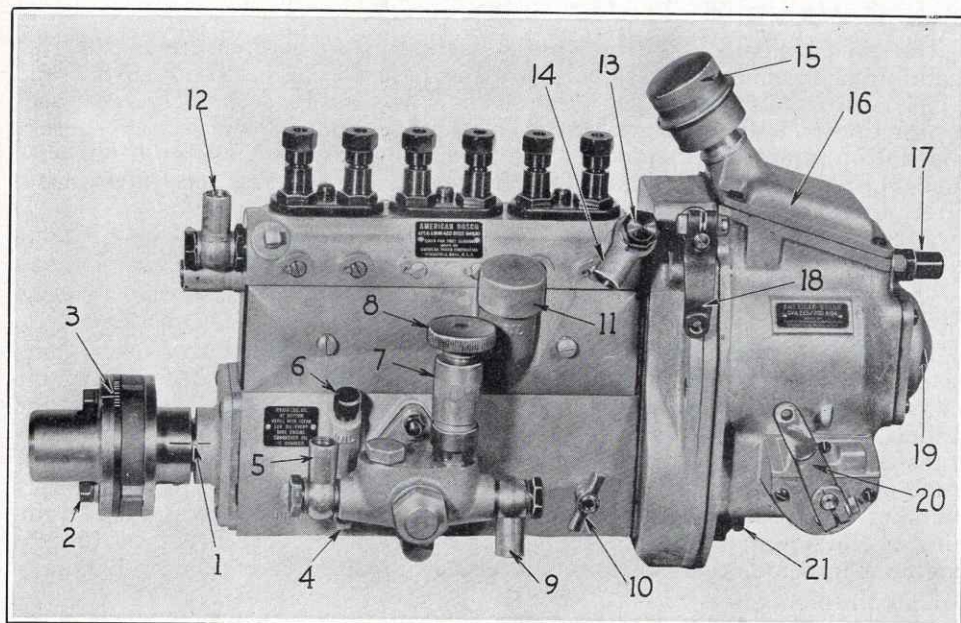

Illustration No. 3

Illustration No. 3 shows the Bosch Injection Pump with Bosch governor. Illustration No. 4 shows the Bosch Injection Pump equipped with a Hercules governor. The first type equipment is the preferable automotive installation. For industrial use the Hercules governor described in the section starting on page 45 is preferable.

Various parts of the fuel injection equipment with the care which each should receive will be taken up separately in the following paragraphs.

LUBRICATION:

Since lubrication of the various fuel injection parts is essential we will cover this phase first. The pumps shown in Illustrations 3 and 4 are oiled by means of a pool of oil in base of the pump and the oil level should be maintained at all times either to the mark on the dip stick shown as 6 in Illustrations No. 3 and No. 4, or by the oil level test cock shown as 10 in Illustrations No. 3 and No. 4. On these pumps new oil is added through the breather hole opened up by removal of cap 11 in Illustration No. 3. This oil should be the same as is used in the lubrication of the engine.

Lubrication of the Bosch governor on the Bosch pump is through the fuel injection pump on units which are interconnected and have a common sump, on other units it is necessary to put oil in governor through breather 15, Illustration No. 3. See above for procedure.

The Hercules governor is filled with oil (of the same grade as used in the engine) through the plug 15 in Illustration No. 4 until it runs out of test cock 23.

GOVERNORS:

These are covered in another section of this book, see page 30 and page 45.

CHECK VALVE:

The check valve on the fuel outlet maintains a set pressure in the fuel manifold of the pump. These parts are shown as 13 in Illustrations No. 3 and No. 4. Should dirt or lint get between the valve and its seat, the valve ceases to function and the pressure on the manifold is reduced which may cause a slight drop in power. Remove and hold valve open while washing it out with fuel oil, kerosene or gasoline. Do not completely disassemble unless absolutely necessary.

The fuel return line should be fastened by proper fittings to opening 14 in Illustrations No. 3 and No. 4.

FUEL TRANSFER PUMP:

The Transfer Pump (early type) is located on the side of the lower pump case (not illustrated) and is actuated by one of the cams on the fuel pump camshaft which moves the pump plunger and, through suitable valves and drilled passages, delivers the fuel to the final filter, located between the transfer pump and the injection pump. The priming handle actuates the same plunger as the camshaft and, should the engine be in the position where Number One cylinder is near the end of the compression stroke and the beginning of the power stroke this plunger is inoperative. Therefore, see that the engine is in some other position before working the Bosch priming handle.

The Transfer Pump (positive type) consists of both a mechanically operated piston type pump (driven by one of the lobes on the injection pump camshaft) and a separate hand operable plunger type priming pump (No. 7

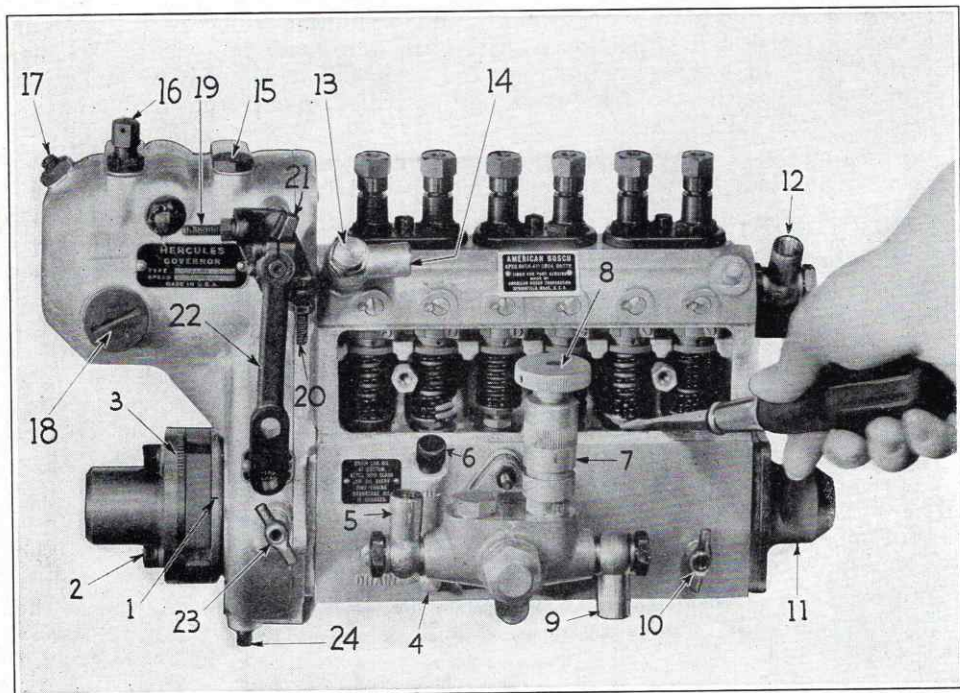

Illustration No. 4

and 8, Illustrations No. 3 and No. 4). The hand priming pump is positive in operation regardless of the engine cycle or position of the injection pump camshaft. The mechanically operated transfer pump serves through a suitable arrangement of piston and valves, to draw fuel from the main supply tank, through suitable primary filters and deliver this fuel, through the final filter located between the transfer pump and the injection pump, to the injection pump.

Dirt sometimes gets imbedded in the transfer pump valves and reduces its efficiency if not actually causing the pump to cease working. Remove the valves and clean or replace from spares. The springs of these same valves sometimes break. Replace from spares when this trouble is found. Use only genuine parts in replacement as substitutes may cause considerable damage.

For complete priming details see page 8.

FUEL INJECTION PUMP (BOSCH)

The Bosch fuel injection pump shown in Illustrations No. 3 and 4 has a camshaft, mounted on ball bearings in the ends of the case, whose cams operate the six plungers inside their respective barrels through suitable tappets, rollers and springs. The helix on the plunger controls the amount of fuel delivered to the fuel nozzle. The relation of the helix to the port holes in the fuel manifold of the pump is controlled by a toothed segment on the plunger mechanism working in a toothed control rod which in turn is connected to the governor. The plunger compresses the fuel and forces it through the delivery valve, fuel pipes and through the spring loaded nozzle into the engine combustion chamber.

IMPORTANCE OF CAREFUL PUMP ALIGNMENT

It is important that the American Bosch fuel injection pumps when mounted on Hercules engines be carefully aligned as any misalignment sets up severe stresses in the pump camshaft and engine drive shaft which is transmitted to supporting bearings. The flexible coupling through which the pump is driven is designed to protect both shafts and bearings from damage caused by slight misalignment but the coupling cannot compensate for gross errors in installation.

The pump housing is chamfered at its base and the governor which is attached to the pump is designed to provide installation clearance between the pump assembly and the engine crankcase. As might be expected, there is a slight difference from time to time in external casting dimensions of the pump, governor, and engine crankcase which have in some cases prevented correct pump alignment. It is, therefore, very important that whenever a pump is installed on an engine the procedure outlined below should be carefully followed:

1. Try slots of fibre intermediate disc on flanges of steel coupling. If there is any indication of wear on steel or fibre parts, the worn parts should be replaced. The fibre disc must fit smoothly on the steel flanges.

2. Place pump on supporting bracket and engage coupling. Insert securing screws in base of pump and tighten screws finger tight so that pump can be moved by gentle tapping with a block of wood or the end of a hammer handle.
3. The pump camshaft and drive shaft must be parallel and in alignment. The Coupling intermediate disc must float with a clearance of .020"-.040". The pump can be checked for alignment by matching the edges of the two coupling members. The pump can be checked for parallelism, by the use of a feeler gauge inserted in opposite sides of the drive coupling.
4. One of the most important steps in pump alignment is to provide ample end clearance for float of the intermediate disc. After tightening the pump holding screws, recheck this end clearance and be sure it is between .020" and .040". Without this clearance, the coupling is not free to compensate for minor misalignment or out-of-parallel condition.
5. Insert a sheet of paper or .005" feeler gauge back of the pump so that it passes between the engine crankcase and the pump and governor. If the paper or gauge will not slide freely between the two, then the pump and governor must be removed. Inspect the engine crankcase for possible high spots that would cause interference. The high spots should be ground off or removed with a file. It is likewise possible that high spots on the pump or governor may be interfering and they should be removed by grinding or filing.

Failures encountered due to disregard to the above instructions will lead to costly repairs.

FUEL PUMP TIMING:

Timing Fuel Injection Pump By Flowing Method. All flywheels have a line marked DC (Dead Center) and from this line are graduations designating degrees of crankshaft travel. From DC these lines are marked 30° and 40°. Also marked every two degrees from 26° to 40°.

(1) SPOTTING FLYWHEEL:

(a) Rotate flywheel by means of hand crank until DC mark appears in timing hole in bellhousing. Be sure No. 1 piston is just completing the compression stroke and beginning the expansion which can be determined by observing that the No. 6 cylinder exhaust valve is nearly closed.

(b) Rotate the engine in direction of degree graduation marks which is counter-engine-wise several degrees past the 29° mark. (27° for DFXH Model). Then rotate the engine the opposite direction or engine-wise until the 29° mark (27° for DFXH Model) is in line with the mark in the center of the timing hole in the bell-housing. This will then have the crankshaft spotted at 29° before top center (27° for DFXH Model), at which point the fuel pump is set for port closing.

(2) Install pump assembly, tightening all attaching screws but leaving the rear half of coupling loose from front half so pump shaft can be rotated while the drive shaft remains stationary.

(3) Connect all fuel suction and discharge pipes from fuel tank to pump. Install all fuel lines except to No. 1 cylinder.

(4) With governor stop lever in wide open or full load position prime pump as given in page 8, paragraph 6.

FUEL INJECTION EQUIPMENT

(5) Put governor stop lever in stop position and remove pump delivery valve holder from No. 1 pumping unit. Remove delivery valve and spring but not the seat. Replace delivery valve holder finger tight.

(6) Put governor stop lever in wide open or full load position. Fuel now should rush out of the delivery valve holder. Rotate pump shaft over the top and toward the engine by means of the rear half of coupling until fuel flow stops. If fuel did not flow when governor stop lever was first opened, rotate shaft until it does, then back to where it is just off. Use hand priming pump to keep fuel pump manifold supplied with oil.

(7) Very carefully rotate shaft until fuel just barely flows then back to point where flow is just barely shut off. Repeat this two or three times until a movement of less than $\frac{1}{4}$ " on the circumference of the coupling is the difference between fuel flowing and not flowing. This determines where the pump plunger just closes the fuel port and begins the period of building up pressure in the lines and nozzles so that injection can start and it is very necessary this adjustment be extremely accurate.

(8) With capscrews provided connect the front and rear half of the coupling together. Be sure these screws are tight so no slippage can occur and yet do not strip the threads. It is not advisable to use a wrench over 6" long for tightening. Also observe if any slight movement which might occur while tightening the screws has started the fuel flowing again from the delivery valve holder. When these screws are tight no fuel should flow. The fuel pump is now timed to close the ports at 29° before top center (27° for DFXH Model).

(9) Put governor stop lever in stop position again. Remove delivery valve holder and replace the delivery valve and spring. Install delivery valve holder, tightening firmly. Be careful not to get any dirt, water, or any other foreign matter in or on any of these parts. Do not tighten so tight as to distort fuel pump case.

(10) Connect fuel line from pump to No. 1 cylinder. Prime fuel lines as explained on page 8, being sure the fuel pump, strainer and all lines are full of fuel with no air.

(11) Start engine. If engine runs ragged or one cylinder cuts out see page 80 for remedies. If after checking all points engine still runs ragged, stop and recheck timing.

(12) After engine is operating smoothly and has been properly warmed up, stop engine.

(13) With light chisel and hammer enlarge the single mark on the front hub and put a corresponding mark on the other hub so these two parts can be lined up together at any future time without the necessity of flowing the pump. See Illustrations 3 and 4, No. 1.

Fuel Pump Timing When Couplings Are Marked. When engines are shipped from the factory the couplings are marked for fuel injection pump timing as shown in Illustrations No. 3 and No. 4. Before removal of fuel pump assembly from the engine these markings should be carefully checked and if dim or obliterated should be re-marked so that re-assembly can be more easily, quickly, and surely made.

To re-assemble the pump assembly to the engine the following procedure should be followed:

1. Spot engine No. 1 piston at proper degree before top center. See page 24, paragraph (a) and (b) for procedure.
2. Install pump assembly on engine—tightening all attaching screws but leaving rear half of coupling loose from front half so pump shaft can be rotated while the drive shaft remains stationary.
3. Rotate rear half of coupling until the heavy mark on it coincides with the heavy mark on the front half of coupling.
4. Install and tighten the attaching screws or bolts which connect the two coupling halves. Make sure the marks are lined up perfectly and the attaching screws or bolts are tight.
5. Install all fuel piping.
6. Prime fuel lines as described on page 8.
7. Start engine.

Timing New Fuel Injection Pump. If a new fuel injection pump is obtained from the Hercules Motors Corporation it will not be necessary to flow the pump as the dust shield and rear half coupling hub are marked at the point of port closing. See Illustrations No. 3 and No. 4. To install a new pump assembly follow this procedure:

1. Spot engine No. 1 cylinder at proper degree before top center. See procedure, page 24, paragraph (a) and (b).
2. Install pump assembly, tightening all attaching screws but leaving the rear half of coupling loose from front half so pump shaft can be rotated while the drive shaft remains stationary.
3. Rotate rear half coupling until the mark on the rear hub coincides with the mark on the dust cover. See Illustrations No. 3 and No. 4.
4. Bolt coupling halves tightly together.
5. Install all fuel lines.
6. Prime fuel lines as described on page 8.
7. Start engine and run until warmed up.
8. When engine operates properly shut down engine and with light chisel and hammer mark rear hub with line corresponding with heavy mark on front hub so these two parts can be lined up together at any future time by following procedure given on page 25.

If engine does not function properly when started, shut down and check the markings of the rear hub and dust seal making sure these marks line up perfectly, also check spotting of flywheel so No. 1 piston is at 29° before top Dead Center (27° on DFXH Model) when these marks line up. After this check if the engine still does not operate properly, flow the pump as given on pages 24 and 25.

FUEL NOZZLE AND HOLDER ASSEMBLY:

The fuel nozzle and holder assembly is shown in Illustration No. 5 clamped in a vise preparatory to disassembling, while Illustration No. 6 shows the complete details of the nozzle and holder assembly, the component parts of which are as follows:

- No. 4 Nozzle Body Retaining Nut
- No. 6 Fuel Nozzle Body
- No. 5 Fuel Nozzle Pintle
- No. 3 Holder Assembly
- No. 2 Holder Fuel Inlet Stud
- No. 1 Fuel Inlet Stud Edge Filter

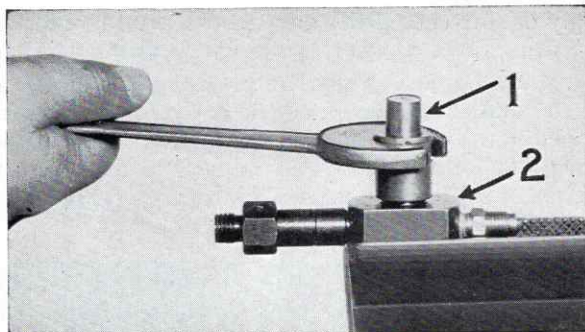

Illustration No. 5

Parts No. 5 and No. 6 are not interchangeable with similar parts of other assemblies and should be used as pairs as originally furnished.

DO NOT MIX THESE PARTS—KEEP THEM IN SETS.

Illustration No. 7 shows sectional view of nozzle and holder.

CARE OF FUEL NOZZLES:

Cleaning spray nozzles is necessitated by:

1. Dirt or foreign matter in the fuel oil which is not removed by the fuel strainers, acid and gum in particular.

2. By overheated engine and spray nozzles causing the fuel oil in the nozzles to decompose or coke around the pintle stem of the valve, spray hole and face of the nozzle.

3. Acid in the fuel oil etching or corroding the nozzle valve and body. This type fuel should never be used under any circumstances. It will ruin the pumps and nozzles. Fuel oil which is contaminated with acid may be detected by dipping one end of blue litmus paper in the oil for a few seconds. If acid is present in the oil the litmus paper will turn pink.

When to clean spray nozzles:

1. When the engine exhaust has increased amount of black or dark smoke.
 2. Loss of power accompanied with foul exhaust or increased leakage of fuel through the by-pass leak-off of spray nozzle.

3. When engine runs rough or "ragged."

4. Irregular fuel knocks.

5. Engine missing on one or more cylinders continuously.

Cleaning and Testing Spray Nozzles. The most important part of spray nozzle cleaning, testing and examination is **CLEANLINESS**. Spread some clean paper on the work-bench and have available a clean dish or open container of clean fuel oil or kerosene, approximately one pint is sufficient.

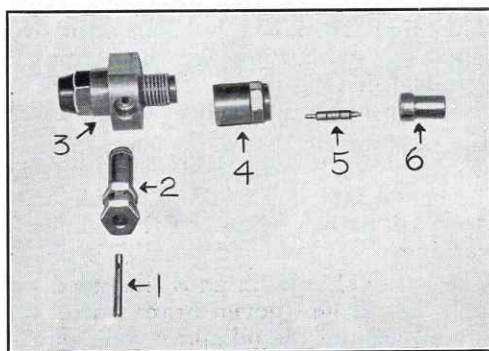

Illustration No. 6

Also have a supply of soft (not fluffy), dry, clean, wiping cloths, a clean squirt can of clean lubricating oil or a jar of vaseline available.

Spray nozzles should be cleaned by first soaking them in kerosene or clean fuel oil to soften the dirt. The interior of the body can be cleaned with a small strip of wood dipped in the cleaning oil and the spray hole with a pointed piece of wood. The nozzle valve should be rubbed with a clean oil soaked rag (but not fluffy). Hard or sharp tools, emery paper, crocus cloth, grinding powder or any abrasive of any kind should never be used.

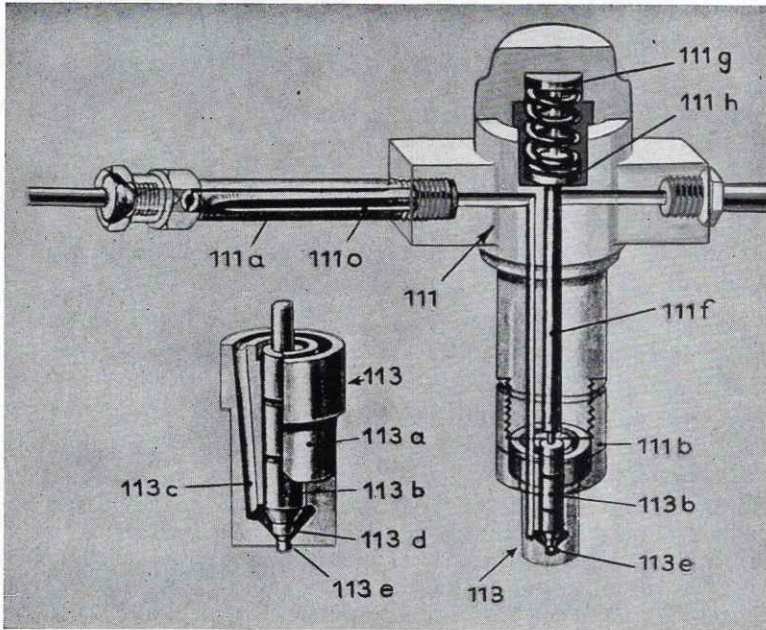

Illustration No. 7

Before assembling, wash and rinse all parts carefully and have them perfectly clean and smear with good clean lubricating oil or vaseline so that valve revolves freely. Tighten the nozzle retaining nut up hard.

The edge filter, No. 1, Illustration No. 6, inside of the fuel inlet tube, is cleaned by unscrewing the tube from the nozzle holder, No. 3, Illustration No. 6, and driving the strainer out with a punch, from the nozzle holder end. Rinse thoroughly with clean oil before reassembling.

If spray nozzle testing is necessary, this can be done on a hand operated testing unit or it may be done by running the engine with the spray nozzle to be tested attached to the fuel delivery pipe, but not installed in the engine, and occasionally setting the throttle in full load position momentarily, while observing the spray and possible leakage.

The spray should be an 8° included angle and should be smooth and even, that is free from uneven branches or streams and the same thickness of oil spray all around the oil spray cone as observed 2 to 5 inches from the nozzle. Unevenness or roughness of the stream indicates a dirty nozzle hole and pintle of valve which must be polished with a pointed stick and soft cloth.

FUEL NOZZLE PRESSURE

If there should be an "after dribble" or "drool" of oil out of the nozzle after the spray is completed, it indicates that the nozzle hole and pintle are not clean and should be polished as above. Be sure both valve and barrel are perfectly clean, with no lint, dirt or foreign substance on surface of either when assembling.

FUEL NOZZLE PRESSURE

Fuel nozzles should be set for 2000 pounds per square inch pressure on a static fuel nozzle testing fixture (this fixture may be purchased from the Hercules Motors Corporation, Canton, Ohio, U.S.A.) However, no adjustment is required if this pressure has only dropped to 1950 pounds.

Adjustment is effected by removing the cap nut and adding or removing shims to increase or decrease the spring tension, thus raising or lowering the pressure.

New nozzle and holder assemblies are shipped from the factory set at 2050 pounds to compensate for the setting of the spring in the first few hours running.

Never attempt to adjust pressure without the proper testing fixture.

**PROPER FUEL AND CLEANLINESS
WITH CORRECT NOZZLE PRESSURE
INSURE TROUBLE FREE OPERATION**

GOVERNORS

BOSCH VARIABLE SPEED GOVERNOR (GVA)

DESCRIPTION:

The purpose of these governors is maintaining within close regulation any desired engine speed within the nominal idling and nominal maximum speed range, irrespective of engine load. In addition, this governor controls the engine idling speed to prevent stalling and the maximum speed to prevent racing.

The governor is an enclosed unit, mounted to one end of the fuel injection pump, Illustration No. 3. A large gear is mounted on the end of camshaft which extends into the governor housing and drives a smaller gear connected to the flyweight shaft. Through this combination of gears, the flyweight shaft is caused to travel at a higher speed than the injection pump camshaft. The centrifugal force exerted by the revolving weights causes a movement of the sleeve assembly 9, Illustration No. 8. This movement is opposed by the compression of the governor springs. The governor is internally connected to the injection pump control rod.

FUNCTION: (All Illustration Numbers refer to Illustration No. 8 unless otherwise stated).

The governor operating lever is connected to the throttle lever of the engine and is set to maintain a desired engine speed under a certain load. When the load changes, the governor acts upon the control rod of the injec-

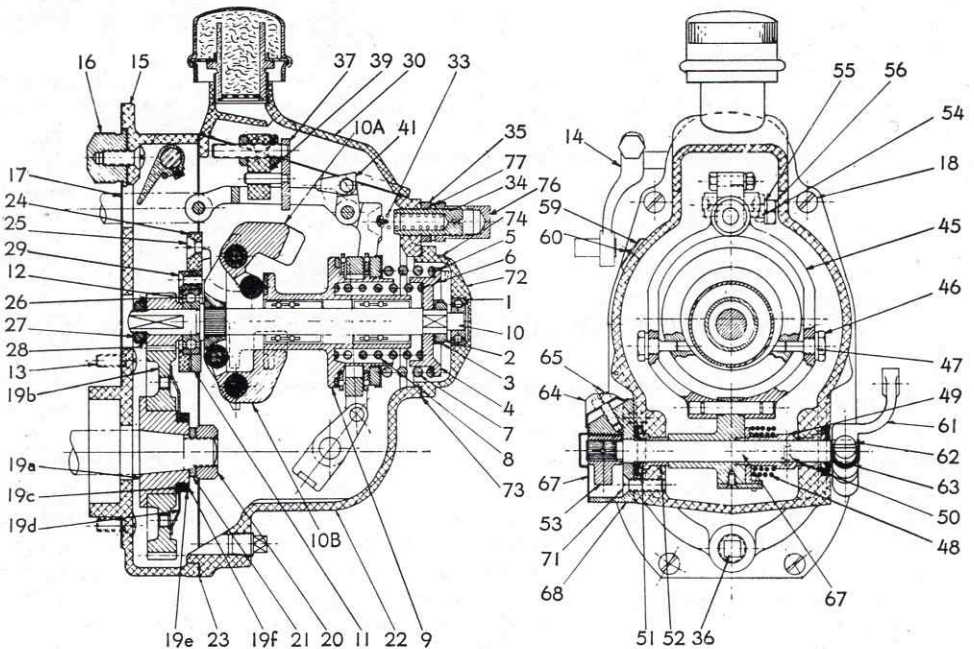

Illustration No. 8

Items 37, 39 and 41 in this illustration are not used in Governors on Hercules Engines.

FUEL PUMP GOVERNOR

tion pump to provide the proper fuel quantity to maintain the same speed under the new load.

If the load on the engine is decreased, the engine tends to accelerate, providing the fuel injection pump is allowed to deliver the same amount of fuel. However, when the engine accelerates, the governor flyweights move in an outward direction, due to the increased centrifugal force. Since the flyweights are in constant contact with the sliding sleeve assembly 9 while the engine is in operation, this outward movement causes a longitudinal movement of the sliding sleeve away from the injection pump against the compression of the governor springs which oppose this movement. The movement continues until an equilibrium is established between the governor spring forces and the centrifugal force exerted by the governor flyweights. The fulcrum yoke assembly 45 is connected to the sliding sleeve assembly by means of the pivot screws 46 and turns about the shaft. As the fulcrum yoke assembly follows the movements of the sliding sleeves, it moves the injection pump control rod towards the stop position and less fuel is delivered by the pump and the engine returns to the pre-set speed.

If the load on the engine increases, the engine tends to slow down, thereby causing an inward movement of the flyweights. As the weights move inward, resulting in reduced force on the sliding sleeve, the compressed governor springs shift the sleeve towards the fuel pump until the spring forces and the centrifugal force exerted by the flyweights are balanced again. In this way, the fulcrum yoke assembly, following the movement of the sliding sleeve, moves the control rod of the fuel pump towards more fuel position and thereby returns the engine to the pre-set speed.

In Illustration No. 8, the upper governor flyweight 10A is shown in position of full load and maximum speed. The relative position of weights for no fuel or engine shut-down is shown by lower weight 10B.

With the operating lever of the governor in any one position, the governor maintains a certain engine speed, regardless of the changes in the load on the engine, as long as this speed is within the idling and maximum speed range.

In order to decrease or increase the engine speed, the operator shifts the throttle lever in the proper direction and thereby also the governor operating lever 61 to which it is connected. As the operating lever shaft 67 with the hub of the fulcrum yoke assembly is rotated, the fulcrum yoke assembly turns about the pivot screws 46 and moves the control rod of the injection pump. The quantity of fuel delivered is either decreased or increased, depending upon the direction in which the operating lever is moved. Irrespective of whether the engine speed was decreased or increased by resetting the operating lever, the flyweights will at once adjust themselves to the altered speed and will move the sliding sleeve 9 until a position is reached where the sleeve regains control over the movements of the fulcrum yoke assembly, which it had lost momentarily when the fulcrum lever was actuated directly by the operating lever.

The fulcrum yoke hub is not rigidly connected to the operating lever shaft but is linked through a double torsional spring 48 mounted on a separate hub 49 fastened to the operating lever shaft. The two open ends of the spring are so designed as to straddle the extension piece of the fulcrum yoke hub, as well as the lip on spring hub 49. This spring construction serves three purposes:

(a) To avoid loading of the operating lever with the opposing centrifugal force of the flyweights, in the event the lever is shifted so that the fulcrum

assembly and the control rod are pushed towards full load for accelerating the engine, as well as to avoid loading of the lever with the opposing governor spring forces in the event the lever is shifted so that the fulcrum assembly and the control rod are pushed towards stop for decelerating the engine. The spring winds up whenever the operating lever is shifted in either direction, without interfering with any opposing forces, and unwinds as the flyweights adjust themselves to the altered speed.

(b) To prevent the governor operating lever from being forced into different positions by changes in the load on the engine, causing a change in speed and resulting in an unbalance in the centrifugal force of the governor flyweights and the spring force, the spring winds up and unwinds again only when the forces are balanced.

(c) To absorb the inertia shocks created by the rotating masses of the governor upon sudden acceleration or deceleration of the engine. The spring absorbs these shocks by winding up and unwinding again as equilibrium is reestablished.

The adjustable bumper spring 33 provided in the governor end cover 22 prevents rapid oscillations of the control rod at high "no load" engine speeds. The spring contacts the fulcrum yoke assembly at high "no load" speeds only and insures steady operation of the governor at these speeds. The spring does not contact the fulcrum yoke assembly at low idle speeds. The bumper spring also assists in preventing stalling of the engine upon sudden deceleration of the engine from high to low idle speed.

Two adjusting screws are provided on the governor, one to limit the movement of operating lever in the direction of full load speed and the other to serve as an idling adjustment. A rigidly-pinned stop plate 53 is provided on the operating lever shaft.

A friction clutch is built into the governor drive gear 19b. The clutch is so designed that it causes the drive gear to slip on its hub 19a whenever changes occur in the speed of the injection pump camshaft. As the camshaft speed returns to normal, the drive gear again follows the speed of the hub.

INSTRUCTIONS FOR DISMANTLING AND ASSEMBLING GOVERNOR

PRECAUTIONS:

In the event it is necessary to dismantle the governor, it is suggested that the complete fuel injection pump assembly be removed from the engine. The injection equipment can then be taken to a clean table or work bench. When removing the unit from the engine, the following precautions should be taken:

1. Before removing any oil lines from the pump, thoroughly clean the equipment with fuel oil. When the lines are removed, the openings on the pump should be covered or plugged to prevent dirt from entering the system.
2. Remove inspection cover of injection pump. Slowly turn the engine over until it is noted that the plunger of the pumping element closest to the pump drive coupling is in its top position. If the engine is left in this position and the adjustment of the coupling is not touched, the pump can be reinstalled in this position on the engine without the necessity for retiming.
3. Disconnect the engine throttle linkage from the governor operating lever. Do not remove the governor operating lever from its shaft or alter its position.
4. Remove complete injection pump assembly.

DISMANTLING THE GOVERNOR: (After Injection Pump Is Removed from the Engine).

1. Remove pipe plug 21, Illustration No. 3, and drain all lubricating oil from governor. As there is an open connection between the injection pump camshaft compartment and the governor, the governor should be tilted downward in order that all oil may be drained.

2. Remove six governor housing fastening screws 18, Illustration No. 9. Four are located on the front side and two are on the rear of the governor housing.

3. Carefully withdraw governor end cover approximately one inch away from the housing and then slightly shift the governor assembly in a sideways movement toward the inspection cover side of the pump in order to disengage the control rod linkage pin 54, Illustration No. 9, from the extension arm 45A, Illustration No. 9, of the fulcrum yoke assembly. The governor end cover is then free.

4. Remove governor end cover gasket 23, Illustration No. 9. If this gasket has not been damaged it may be used again when governor is reassembled.

5. Remove inspection cover 30 and gasket by unscrewing four fastening screws 31, Illustration No. 9.

6. The governor adjustable bumper spring assembly, as shown in Illustration No. 8, is comprised of bumper spring 33, adjusting screw 34, lock nut 35, dust cap 76 and gasket 77. This assembly has been set at the factory and should not be changed. If the bumper spring assembly must be removed,

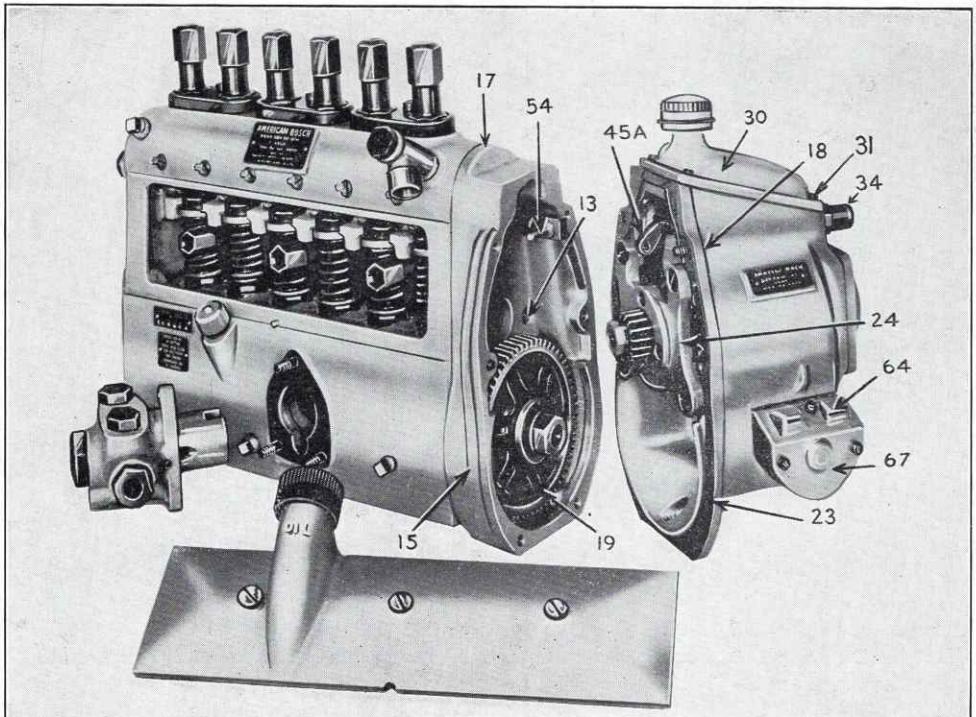

Illustration No. 9

HERCULES MOTORS CORPORATION

necessary measurements must be taken in order that the assembly can be reinstalled in the same position. For resetting the bumper spring assembly, refer to item 8 under "Adjusting the Governor on the Engine."

7. The position of the governor operating lever is important. Some governors have a scratch line across the end of the lever shaft which registers with a mark on the operating lever. On those governors where there are no marks on the operating lever or shaft end, a scratch mark must be inscribed on the lever shaft before disassembly, in order that these two parts can be clamped together in their proper relative positions when the governor is re-assembled. The operating lever can be removed by loosening the operating lever clamp screw.

8. Remove cover plates 64 and 67, Illustration No. 9, by unscrewing three fastening screws.

9. Using a $\frac{1}{16}$ " hex socket wrench (service tool TSE 7918), remove set screw 50, Illustration No. 10.

10. Slide out operating lever shaft 53, Illustration No. 10.

11. Unscrew four fastening screws holding bearing bridge 24, Illustration No. 10, to governor end cover and carefully pull out the internal operating parts of the governor as a unit.

12. Should it be necessary to remove end cap 72, Illustration No. 10, in order to replace the ball bearing in the cap, unscrew four fastening screws 74.

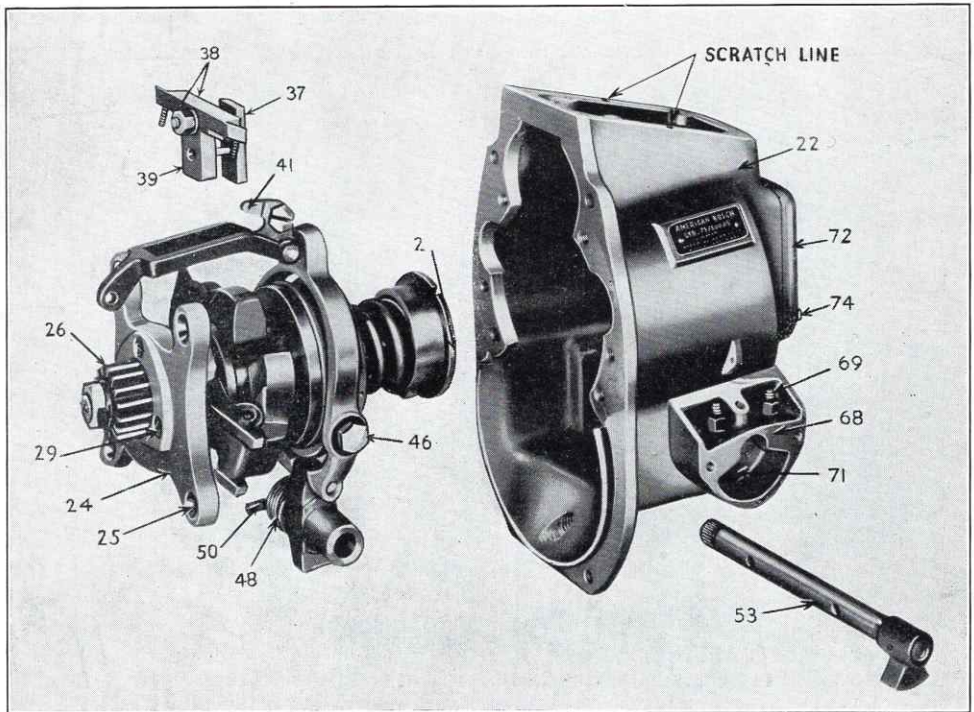

Illustration No. 10

Items 37, 38, 39 and 41 in this illustration are not used in Governors on Hercules Engines.

FUEL PUMP GOVERNOR

The ball bearing can be removed by using special puller (service tool TSE 7916).

13. If it is necessary to remove stop flange 68, Illustration No. 10, in order to replace operating lever shaft oil seal or bearing, the stop adjusting screws must be loosened and the three flange fastening screws 71 must be removed. Before disturbing the setting of the stop adjusting screws, a measurement should be recorded in order that they may be reassembled in approximately the same position.

14. Withdraw operating lever spring 48, Illustration No. 10, and hub as a unit.

15. Unfasten pivot screws 46, Illustration No. 10, to disengage fulcrum yoke assembly 45, Illustration No. 8.

16. Remove hex nut 28, Illustration No. 11, and locking washer 27 and withdraw driven gear 26 from flyweight shaft.

17. Slide bearing bridge 24 from shaft.

18. The ball bearing in the bridge may be removed by unscrewing three fastening screws 29 which hold the bearing plate.

19. Remove hex nut 2 and locking washer 3 from end of shaft.

20. Slide spring seat 4 from shaft.

21. Remove governor springs (one or two are used, depending on governing speed requirements), being careful to retain all outer and inner spring spacers 5 and 6. The inner spring spacers may either be located on the side next to the spring seat or against the sliding sleeve assembly.

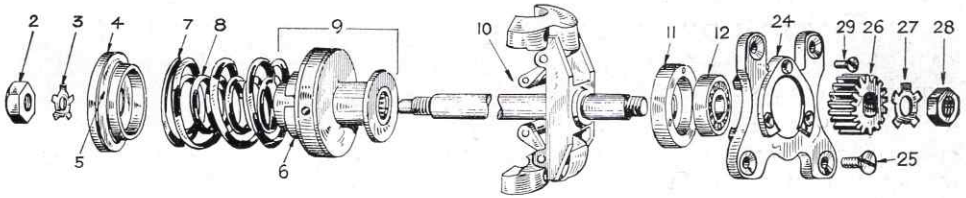

Illustration No. 11

22. Disengage sliding sleeve assembly 9 from flyweight assembly 10. Do not disengage these two assemblies unless necessary as separating these parts might permit the balls of shaft bearings to drop out. No attempt should be made to disassemble either of these assemblies since their component parts are not serviceable.

Reference should be made to Illustration No. 11, which clearly indicates the position of the internal parts with respect to one another.

23. The drive gear and friction clutch assembly 19, Illustration No. 12, can be removed from the injection pump camshaft extension by first removing hex nut 20 and lock washer 21. Proceed with the removal by unscrewing securing nut 19f, using special wrench (service tool TSE 7919). It will be necessary to keep the camshaft of the injection pump from turning, by holding the coupling at the opposite end of the pump. With the securing nut removed, the

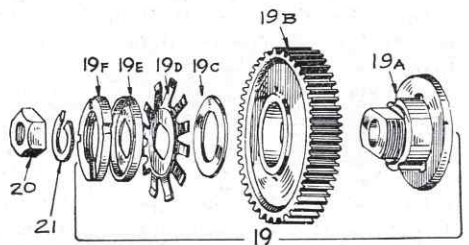

Illustration No. 12

lock washer, spring disc, adjusting spacer or spacers, and drive gear 19e, 19d, 19c, 19b may be removed.

24. Use special puller (service tool TSE 7920) on thread of hub 19a to withdraw the hub from the camshaft taper.

A puller should never be used in the two threaded holes which are in some driven gears, since it has been found that in pulling against the spring disc 19d serious distortion of this spring is liable to occur.

25. It is not necessary to remove the governor housing 15, Illustration No. 9, to repair the governor or injection pump, even if it is necessary to remove the pump camshaft. If, for some reason, it is necessary to remove the housing, proceed as follows:

The governor housing and gasket 15 and 17 can be removed by unscrewing four fastening screws and one screw inside top of housing. The governor housing acts as an end plate for the camshaft of the pump. It is, therefore, necessary to install tappet holders (service tool EF 8183) under the tappet screws of the injection pump to insure that the internal parts of the injection pump do not fall out of position when the camshaft is not held up by the bearing in the governor housing.

26. In type GVA only there is a linkage arm between the fulcrum yoke extension arm 45A, Illustration No. 9, and the injection pump control rod. This can be removed by unscrewing fastening screw 58, Illustration No. 13.

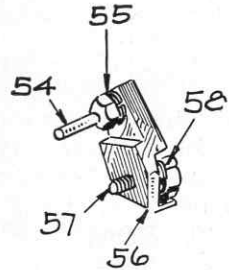

Illustration
No. 13

EXAMINATION OF PARTS—WHEN TO REPLACE THEM:

(All Illustration Numbers refer to Illustration No. 14 unless otherwise stated)

The individual parts of the governor should be carefully washed in clean fuel oil or gasoline.

Gaskets, Fastening Screws, Nuts and Washers: These parts should be replaced if at all damaged.

Drive Gear (26): Should be inspected for wear or broken teeth and should be replaced if necessary.

Ball Bearings (1 and 12): Should be inspected for excessive wear and replaced if not in A1 condition.

Governor Springs (7 and 8): Should be free from any rust spots or signs of corrosion.

Sliding Sleeve Assembly (9): Should be carefully inspected as to condition of bearings. The two shaft bearings 9A must not be loose and the small balls in these bearings must all be in place. There is a floating ring 9B between the stationary thrust surfaces 9D of the sliding sleeve assembly, and two thrust bearing plates 9C. The total clearance between these parts should not exceed 0.006". In making a check for the proper clearance, the feeler gauge should be inserted between the ring and either one of the bearing plates to get the advantage of a larger contact surface. It is important that the feeler gauge be inserted far enough to go between the balls of the bearing plates and the ring. No attempt should be made to repair the sliding sleeve assembly; the entire assembly should be replaced as a unit.

Flyweight and Shaft Assembly (10): The rollers 10A must not be worn or loose on their holding pins. The flyweights should move freely on pivot pins 10B but must not be too loose.

FUEL PUMP GOVERNOR

Bumper Spring (33): Early types of springs were not provided with a steel button on the end. It is desirable that these early types be replaced, since the button makes a better contact with the fulcrum yoke and eliminates the possibility of the spring catching in the yoke cup.

Fulcrum Yoke Assembly (45): There must not be excessive play of the linkage arm 45A and pin 45F with respect to the yoke 45. There must not be excessive play between the hub 45C and the yoke 45. Extension piece 45D must not be distorted and must be firmly staked in place. If the yoke is distorted or if the play between the linkage arm and the yoke and between the hub and the yoke is excessive, the whole assembly must be replaced as a unit.

Operating Lever Shaft Oil Seals and Bearings (51 and 52): Should be inspected for wear or damage and should be replaced if necessary.

Operating Lever and Shaft (53 and 61): The pin 53A should be tight in place and the stop plate sector should not be loose on its shaft. The hole 61A in the operating lever should not be excessively worn. Serrations on both the control lever and shaft should be in good condition.

Stop Adjusting Screws and Nuts (69 and 70): If it has been necessary to remove these parts or replace them, this fact should be noted so that they may be re-set in the proper positions after the governor and injection pump assembly is installed again on the engine.

Drive Gear and Clutch Assembly (19): The drive gear 19B should be inspected for excessively worn or broken teeth. The surface on the face of the gear which contacts the clutch disc 19D should be smooth. The hub 19A should be inserted into the drive gear 19B and the clearance between the two parts should not be excessive, to the extent that the gear could act eccentrically. Spring disc 19C, lock washer 19E and lock nut 19F should be replaced if damaged or badly distorted.

ASSEMBLY OF THE GOVERNOR

(All Illustration Numbers refer to Illustration No. 14 unless otherwise stated)

CAUTION: Do not attempt to assemble governor before reading the following instructions:

1. After the parts have been carefully cleaned, inspected and replaced when necessary, in accordance with the instructions outlined in the preceding section, the governor can be reassembled.

2. Ordinarily, it will not be necessary to install the governor housing 15 as this part need not be removed to repair the governor or injection pump, even when it is necessary to remove the pump camshaft. However, if for some reason it has become necessary to install a new governor housing, proceed as follows:

Press the outer race of the camshaft ball bearing into the housing. No packing seal is required between the pump camshaft and governor compartment. The end face of the injection pump must be absolutely clean. The governor housing 15 and gasket 17 can be installed and secured by four fastening screws 13 and screw 14 in the upper part of the governor housing. The camshaft end play of the injection pump should then be carefully checked,

HERCULES MOTORS CORPORATION

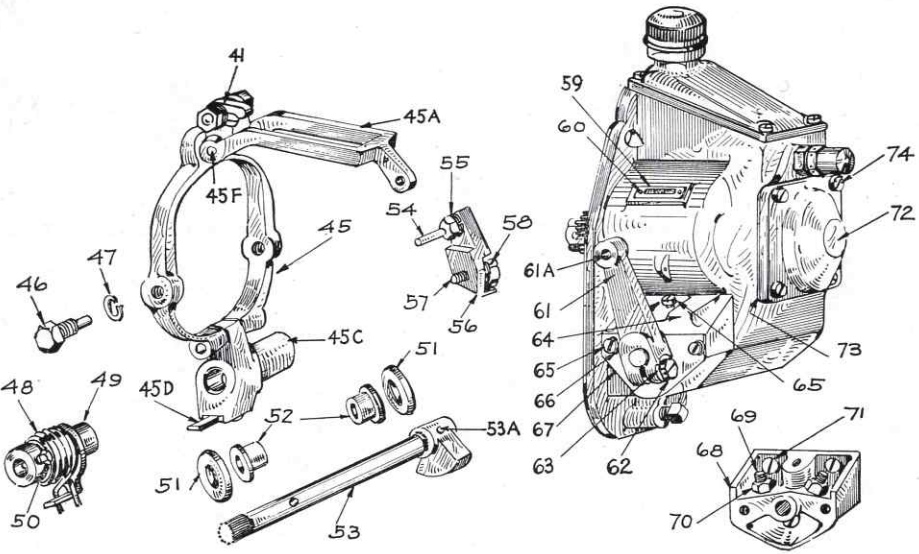
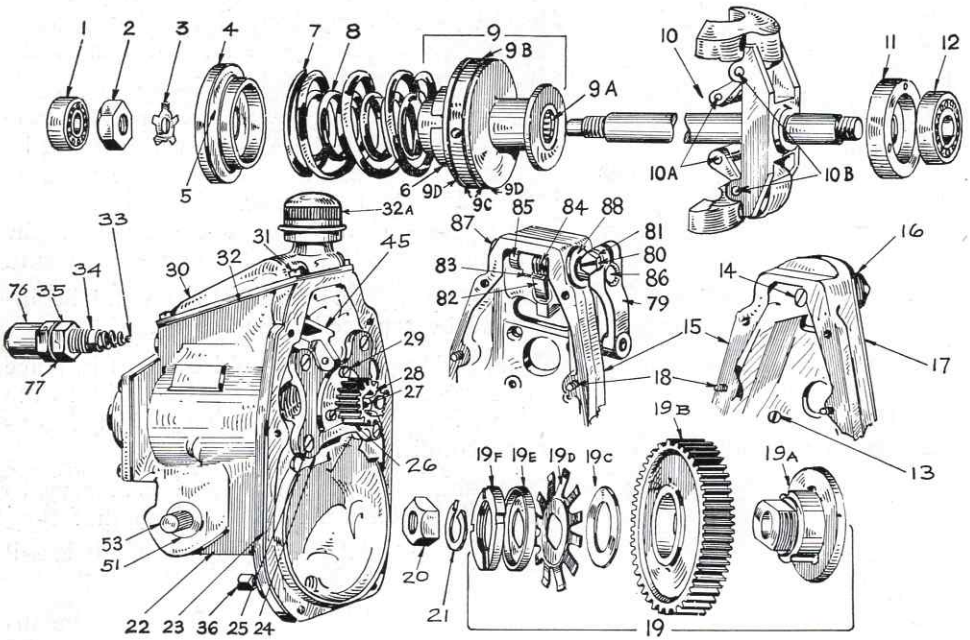

Illustration No. 14

Item 41 in this illustration is not used in Governor on Hercules Engines.

and should be within the limits of .004" and .010".

3. With the housing properly installed, the drive gear and clutch assembly 19 should be mounted on the extending camshaft taper. No key is used, although a keyway is provided in the camshaft taper. The clearance between the drive gear hub and the drive gear should be re-checked after the hub has been securely tightened on the camshaft taper. With ample clean lubricating oil between the hub and the drive gear, the latter should rotate freely and easily without binding in any position. If necessary, the gear and its hub may be lapped slightly to provide a nonbinding assembly. Reassemble the

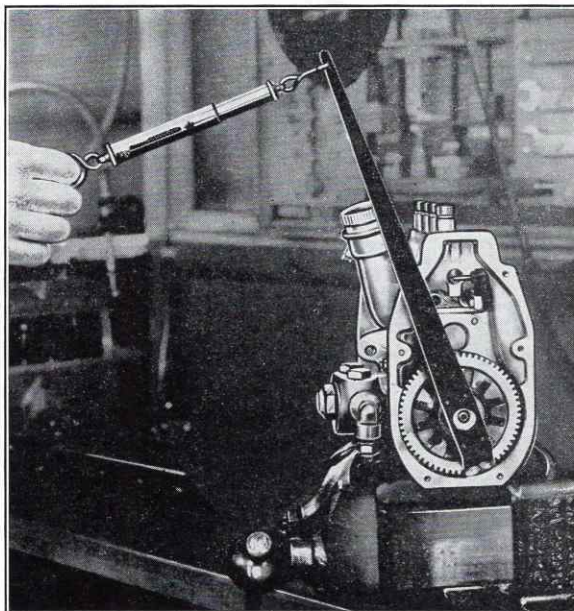

Illustration No. 15

component parts of the clutch assembly in the relative positions, as shown in 19, Illustration No. 14.

With the securing nut 19F firmly tightened, the clutch tension should be carefully checked, as illustrated in Illustration No. 15. The friction surfaces of the drive gear 19B and the spring disc 19D should be well covered with lubricating oil. The gear should rotate with a steady pull of approximately $2\frac{1}{4}$ to $2\frac{3}{4}$ foot pounds. A one-foot lever, service tool TSE 7928, is used to measure this pull with spring scale TSE 7927.

The drive gear should move through a complete revolution on its hub, with fairly uniform gear resistance. The gears should not move freely in one spot and rough in another, but should revolve without clutching with the pull of $2\frac{1}{4}$ to $2\frac{3}{4}$ foot pounds. If the tension is too great, install another shim 19C, or if the gear moves too freely, remove sufficient shims to give the proper slippage. Three shim thicknesses are available—0.035", 0.049" and 0.065".

4. Slide the sleeve assembly 9 over the shaft of the weight assembly 10. The bearings within the sleeve assembly should be packed with American Bosch special temperature resisting grease No. US 508.

5. Install governor spring or springs 7 and 8 and slide on spring seat 4, making sure that the proper number of spring spacers 5 and 6 are installed in accordance with the adjustments as given in the governor parts list for the particular type involved. Certain types of governors use only one spring, while others use two. Whenever inner spring spacers are necessary, they should be installed at the sliding sleeve assembly end of the spring.

If the adjustments as given in the governor parts list call for an inner spring gap, this may be measured with service tool TSE 7924. The prongs of the tool are installed through the two holes in the governor spring seat, with the seat tightened against its shoulder by the securing nut 2. Insert the prongs

of the tool until they press against the inner spring, without compressing the spring, and read the gap setting in millimeters directly from the scale. The markings on the scale should be lined up with the outer shoulder of the spring seat. This may be checked by laying a straight edge across these two surfaces. Install or remove a sufficient number of spacers to give the proper adjustment.

6. After completing the proper spring adjustments, the securing nut 2 should be tightened with the lock washer 3 beneath. Bend over the prongs of this lock washer.

7. Slide bearing plate 11 on the opposite end of the flyweight shaft, together with ball bearing 12 and bearing bridge 24. These three parts are clamped together by clamping screws 29.

8. Assemble driven gear 26 on shaft, firmly tighten in place by nut 27, and secure with lock washer 28.

9. Fasten fulcrum yoke assembly 45 to sliding ring 9B of the sleeve assembly by means of pivot screws 46 and lock washer 47.

10. Assemble the operating lever spring 48 to the hub 49. The ends of the coil spring should straddle the spring plate which is an integral part of the hub. The spring may be drawn into position with a wire loop and should be so assembled that it will be under tension. The hub and spring assembly should be slid into the fulcrum yoke hub so the spring straddles spring plate 45D.

11. If necessary to install new control shaft bushings 52 in the governor end cover 22 they should be carefully pressed into position and reamed with a $\frac{3}{8}$ " line reamer. New oil seals 51 which have been previously soaked in oil for at least 24 hours, should be pressed into position with an application of oil resistant sealing compound on their outer circumference.

12. The internal mechanism consisting of the shaft and yoke assembly should now be placed in the governor end cover 22 and fastened in place by the four bearing bridge screws 25.

13. Slide the operating lever shaft assembly 53 in place, being careful not to injure the shaft seals 51.

14. Securely fasten hub for spring 49 to the shaft 53 by means of set screw 50 which has a pilot stud fitting into a hole in the operating lever shaft. A $\frac{3}{16}$ " socket wrench (service tool TSE 7918) should be used for tightening the set screw.

15. If the control lever adjusting screws 69 have been moved, they should be reset to their original position.

16. Secure the cover plate for stop flange 67 with securing screw 65 and lock washer 66.

17. Control linkage pin 54 must be fastened to the control rod of the injection pump by means of lock nut and washer. In the case of GVA governors, extension arm assembly 56 must be installed.

18. Install governor housing gasket 23.

19. Install governor end cover assembly, making sure linkage pin 54 fits into hole of the extension arm 45A of the fulcrum yoke assembly.

NOTE: Before securing end cover to the housing by means of fastening screws 18, make certain that the drive gear does not assume a position where

FUEL PUMP GOVERNOR

there is danger of the outer face of the gear rubbing on the bearing bridge 24. If the teeth of the gear rub, it will be necessary to relocate the camshaft in the injection pump by shifting the bearing spacers. For instructions on this detail, refer to section covering service instructions on the fuel injection pump.

20. Secure governor operating lever 61 by means of screw 62 and lock washer 63. The lever should be installed in the same position as it was removed. Refer to item 7 on dismantling of the governor.

21. Install bumper spring assembly consisting of spring with button 33 and adjusting screw 34. This should be adjusted to its original position and held with lock nut 35.

22. Inspection cover 30 and gasket 32 should be fastened in place with screws 31.

23. If the governor end cap 72 has been removed, it should be reassembled with gasket 73 in position. The end cap bearing should be repacked with American Bosch special temperature resisting grease No. US 508. Secure cap with four screws 74.

24. Install cover plate 64 on governor stop flange with fastening screws 65. NOTE: All housing and cover screws should be staked.

ADJUSTING THE GOVERNOR ON THE ENGINE:

(All Illustration Numbers refer to Illustration No. 16 unless otherwise stated)

1. Remove dust cover 64 from stop flange 68.

2. Withdraw bumper spring adjusting screw 34 as far as possible without allowing it to fall out.

3. Add lubricating oil to the pump until oil flows from the overflow fitting. The pump camshaft and governor compartments are interconnected. Excessive oil is detrimental to the satisfactory operation of the governor and, therefore, care should be taken not to add more oil than is necessary to reach the level of the overflow fitting.

4. The throttle linkage arrangement of the engine is so designed that with the engine hand throttle lever or foot accelerator in full load position, it will compress a spring in the linkage and hold the control lever shaft stop plate against the stop screw 69A. In this manner, the control lever will be spring-loaded when in full load position but the stop screw will not be subjected to the direct force of the operator's hand or foot.

In the same manner, when the operator desires to idle or stop his engine, the governor control lever becomes spring-loaded.

It is important, therefore, to observe the spring loading device in the control linkage and be sure that the operator control lever is not forced directly against the governor control lever at either extreme position, since this can exert undue strain on the stop screws and may result in their breakage.

5. Warm up the engine thoroughly before attempting to make any governor adjustments. By referring to the governor type designation, the engine idling speed and the maximum full load speed may be obtained. Example: GVA 225/600 A10. 225 indicates that the governor idle speed is 225 R.P.M., or in the case of a 4-cycle engine, 450 R.P.M. is the engine idle speed. 600 indicates a governor speed of 600 R.P.M., or in the case of a 4-cycle engine, 1200 R.P.M. maximum engine speed under full rated load. When the engine is under no load, the speed will increase above this governed figure to what is termed a high idle speed. The difference between the rated load speed and the high idle

HERCULES MOTORS CORPORATION

speed is commonly known as regulation and is usually expressed in percentage. If the engine is loaded above its rated load, then the speed will decrease below the rated speed given.

With no load on the engine, move governor operating lever toward full load position until the stop plate on the lever shaft contacts the full load stop set screw 69A. When the engine reaches its maximum speed, check by means of a tachometer whether this is the high idling speed as specified. If the speed is too low, raise the stop set screw and if the speed is too high, lower the screw. After the correct high idling speed is obtained, secure the adjusting screw by means of the lock nut 70 and re-check the speed, making sure that stop plate on governor operating lever shaft is in contact with the set screw.

6. With the engine still operating at the high no-load speed, remove dust cap from bumper spring assembly 34 and turn in adjusting screw until the button on the end of the spring just touches the pocket in the fulcrum yoke assembly 45, without an appreciable increase in engine speed. If extension arm of the fulcrum yoke assembly oscillates rapidly back and forth at high

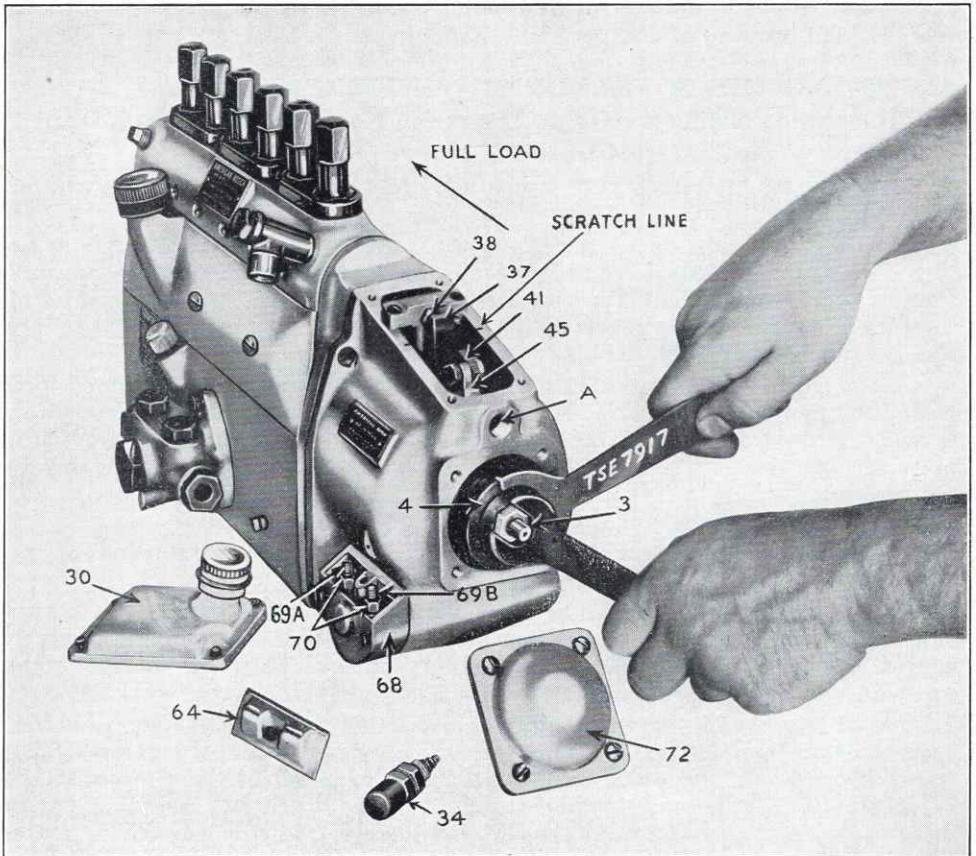

Illustration No. 16

Items 37, 38, 41 and 45 in this illustration are not used in Governors on Hercules Engines.

no-load speed, screw in the bumper spring slightly further until the governor mechanism is reasonably steady.

7. If the governor action appears rough and there is a rapid oscillation of the control sleeves of the fuel injection pump (this action can be noted if the inspection cover of the pump is removed), it is an indication that the tension of the spring disc in the governor drive gear assembly is too tight. A slow surge of the control sleeves of the injection pump is an indication that the spring disc is too loose. In either case, the tension should be re-checked and adjusted if necessary, in accordance with instructions in paragraph 3 of the "Assembly of the Governor" section.

8. Move the control lever in the direction of less speed (toward the injection pump) until the engine reaches the correct idling speed. Hold the operating lever in this position and screw in idling set screw 69B until its lower end touches the stop on the operating lever shaft. Lock set screw in this position. After locking the set screw, re-check the engine idling speed with a tachometer.

9. Sometimes, in order to get the proper maximum full load fuel delivery setting, the operating lever shaft spring is wound up too much and might permit the governor to let the engine reach excessive speeds. The remedy for this trouble is to install a sufficient number of shims behind the inner governor spring (see item 5 under "Assembly of the Governor") or correct the full load speed position of the operating lever by resetting the full load stop set screw.

10. The nominal idling and maximum speeds controlled by the governor cannot be varied to a great extent because they depend entirely upon the characteristics of the spring combination contained in the governor unit. In addition to the external adjusting screws 69A and 69B, slight adjustments are possible by removing or adding adjusting spacers between the inner spring and the sliding sleeve assembly. (See paragraph 5 under "Assembly of the Governor.")

HOW TO CHANGE GOVERNOR SPRINGS WITHOUT DISMANTLING THE GOVERNOR:

(All Illustration Numbers refer to Illustration No. 16)

If for any reason it becomes necessary to change the governor springs, either to replace the springs in the governor or to exchange them for springs providing a different speed governing characteristic, it is not necessary to dismantle the complete governor or remove the unit from the engine—simply proceed as follows:

1. Remove end plate 72 by unfastening four securing screws.
2. Holding spring seat 4 firmly by special Spanner wrench (service tool TSE 7917), remove hex nut 3 with open end or box wrench.
3. After the nut and locking washer have been removed, the spring seat 4 can be withdrawn and the governor springs (and the governor spring spacers if any are used) can be removed and replaced. To obtain the desired spring adjustment, refer to item 5 under "Assembly of the Governor."
4. After new springs have been installed, the governor should be readjusted and tested per instructions given under "Adjusting the Governor on the Engine."

MAINTENANCE:

The governor dust covers and inspection covers should always be kept fastened in place to prevent dust from entering the unit. As the governor unit and the camshaft compartment of the injection pump are inter-connected, they have a common lubrication oil sump. To be sure that the moving parts of the governor are adequately lubricated at all times, the lubricating oil level in the injection pump should be checked every time the crankcase oil of the engine is changed. At such times, the oil should be completely drained from both units (by means of drain plugs located in the bottom of both the governor and the injection pump) and refilled with clean engine oil, preferably SAE 30, through the oil filler of the injection pump, up to the level of the overflow fitting.

THE USE OF PROPER LUBRICATING OIL FREQUENTLY CHANGED WILL REDUCE REPAIRS TO THIS GOVERNOR TO A MINIMUM. SHOULD REPAIRS BE NECESSARY EITHER PROCURE THE PROPER TOOLS OR RETURN GOVERNOR AND PUMP TO MANUFACTURER OR TAKE IT TO AN AUTHORIZED BOSCH SERVICE STATION.

HERCULES MECHANICAL INDUSTRIAL GOVERNOR

(In some illustrations the Governor is shown attached to Pumps not supplied on the DFX Series)

This governor is a self-contained unit designed for integral attachment to the fuel injection pump. All adjustments for proper control of engine speeds can be made externally.

Never use this governor for engine speeds greater than 1800 R.P.M. full load. (At this date, October 10, 1947, 1800 R.P.M. is the limit of this governor. However, in the future this governor may be revised to allow higher speeds.)

LUBRICATION:

Check daily the oil level. This level should be maintained so oil will run out test cock 23 in Illustration No. 4. Use same grade of oil as used in engine crankcase. Too much oil will cause governor to act sluggish. Therefore, keep at correct level. Check oil level only when engine is shut down.

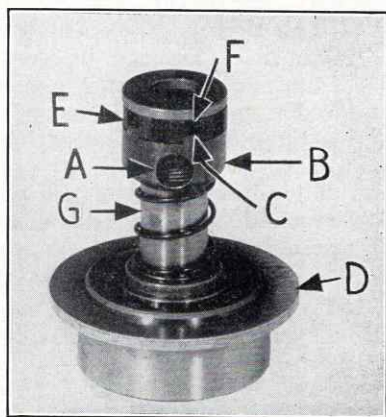

Illustration No. 17

CHECKING TROUBLE:

First check engine, injection pump and nozzles and if these are found in good order then proceed as follows with reference to governor troubles.

If engine runs away, this may be caused by one of the following:

1. Governor thrust sleeve, Illustration No. 17, out of adjustment. Stop engine, remove plug M, Illustration No. 21, and adjust governor thrust sleeve as outlined under "How To Adjust Governor," paragraph 4. If this does not reduce speed, then trouble is elsewhere.
2. High speed control stop 20, Illustration No. 4, not properly adjusted. Loosen lock nut and turn in until engine speed is reduced to that required. (Less than 1800 R.P.M. engine speed.)
3. Thrust sleeve or flyweights in governor stuck or fingers worn. Replace with new parts or governor. (Instructions given later on removal of governor, etc.)

Should engine not idle smoothly, check following sources for trouble:

1. Idle spring out of adjustment. Loosen lock nut on adjustment screw 16, Illustration No. 4, and turn in or out until smooth idle is obtained.
2. Governor thrust sleeve, Illustration No. 17, out of adjustment. Stop engine, remove plug M, Illustration No. 21, and adjust governor thrust sleeve as outlined under "How To Adjust Governor," paragraph 4. Then readjust idle spring adjustment for proper idle. After these changes have been made check top speed action as outlined above under 1.
3. Idle spring bent or caught in yoke. Remove spring and straighten.
4. The hand or foot control linkage worn or out of adjustment. Reset and take out slack in linkage.
5. Thrust sleeve in governor sticking, gears and weight fingers worn. Replace with new parts or complete governor.

Engine speed fluctuating or surging. Thrust sleeve out of adjustment. Readjust as outlined above.

A noisy governor denotes worn parts not correctly assembled. Replace with new unit.

INSTALLATION OF NEW GOVERNOR:

To accomplish this, follow carefully the following steps. Remember cleanliness is essential, therefore cover work bench with clean paper.

Removal of Injection Pump and Governor from Engine

1. Wash complete assembly thoroughly with fuel oil. Use brush and compressed air, if available. Before removing any fuel lines, be sure they and the fittings are clean.

2. Disconnect all high and low pressure fuel lines from injection and supply pump, Illustration No. 4. Cover and plug openings. Remove control rod from governor lever.

3. Remove injection pump inspection cover. Crank over engine until the cam lobe for this unit is in a raised vertical position. (This can be seen through inspection hole.) Leave engine in this position until pump is again installed. If this cam lobe position is carefully noted it can be set in exactly the same position when pump is reinstalled and a tedious timing operation avoided. Do not loosen adjustable coupling clamp screws.

4. Loosen pump mounting bracket or pump hold down screws. (Hold down screws preferable if all of them can be reached without removing bracket.) Remove complete pump and governor assembly from engine. Wash thoroughly with clean fuel oil after removal.

To Remove Mechanical Governor

1. Remove governor drive flange by taking off the cam shaft nut and, using a special gear puller B, (Service Tool 13115-A) Illustration No. 18.

2. Remove Woodruff key from the cam shaft and lay in a clean place. A, Illustration No. 19.

3. Remove all the screws that hold the governor to the governor plate. B, Illustration No. 19.

4. Put the throttle lever in full open position. C, Illustration No. 19.

5. Grasp the governor firmly in one hand and pull it away from the injection pump as far as possible. The governor is dowelled to the plate and may be tapped loose, should it stick.

6. Then lift the governor unit slightly. This will release the governor yoke D, Illustration No. 19, from the control rod pin and rollers E, Illustration No. 19. Be careful not to lose the two small rollers. Remove the rollers.

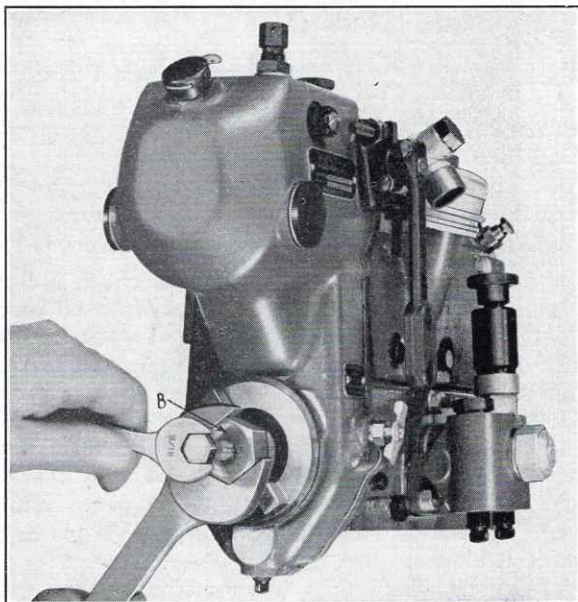
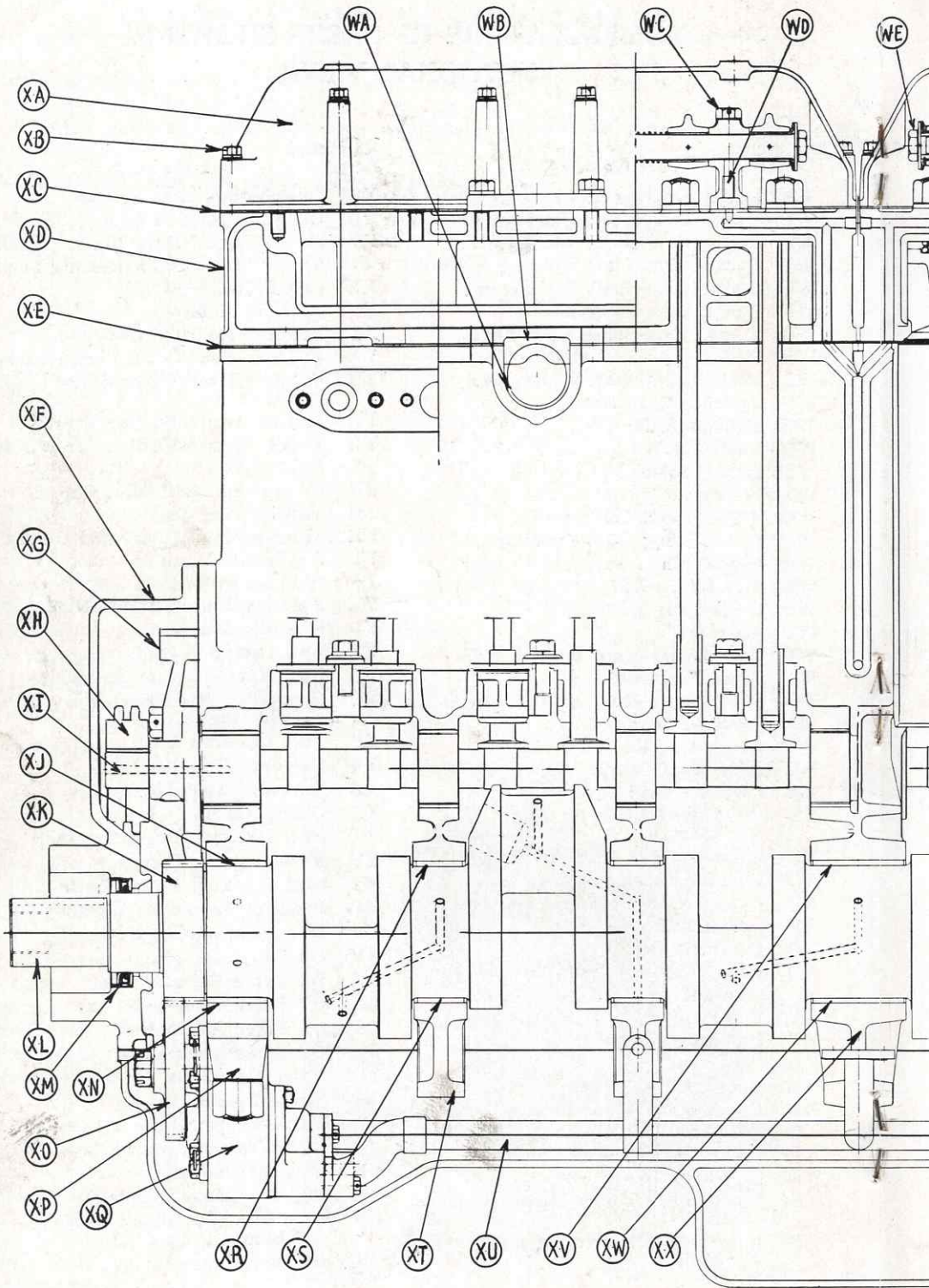
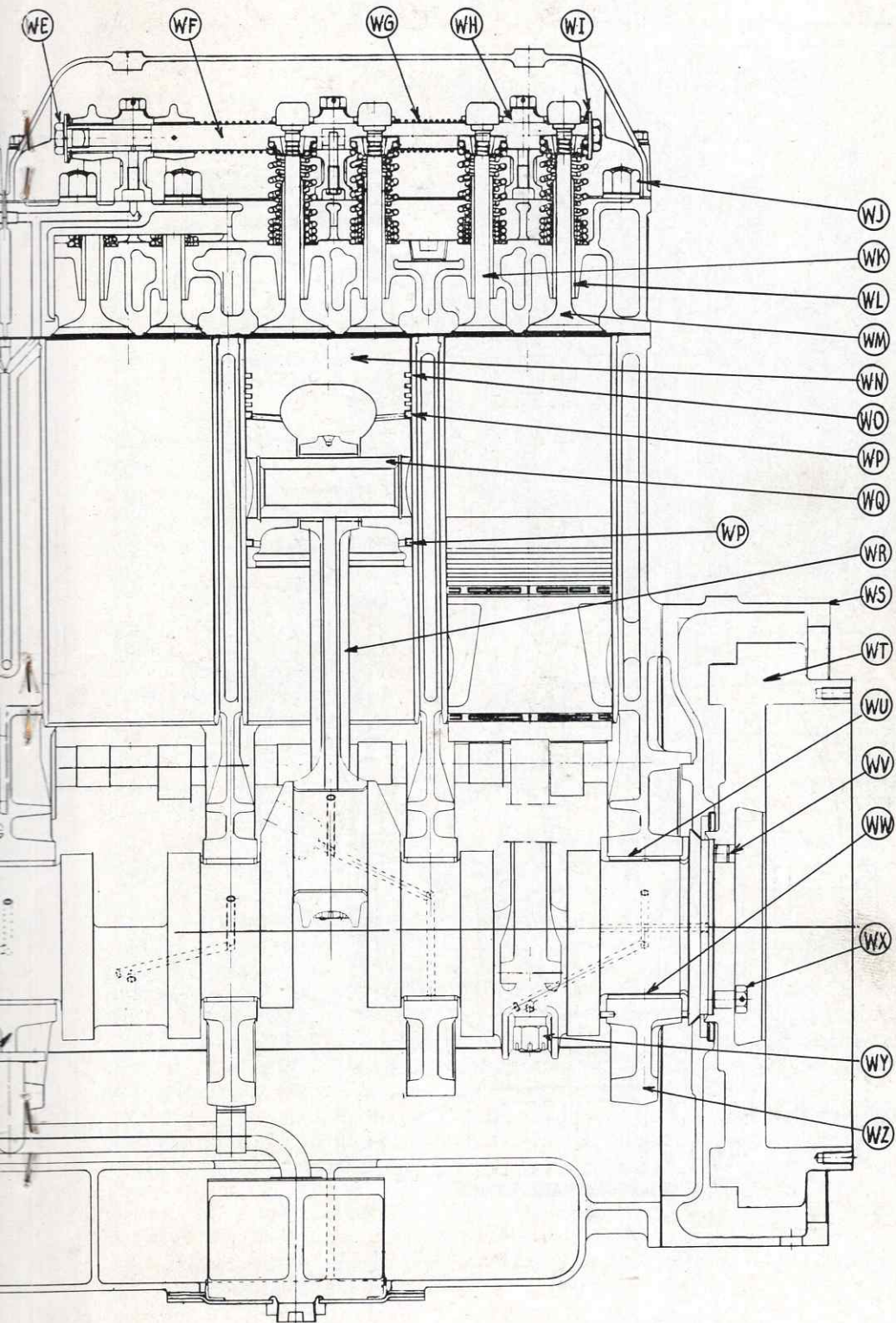

Illustration No. 18

NOMENCLATURE OF PARTS SHOWN IN SECTIONAL VIEWS

Reference Letter	Part Name	Reference Letter	Part Name
WA	Lower Combustion Chamber Liner	XT	Intermediate Bearing Cap
WB	Upper Combustion Chamber Liner	XU	Oil Pump Suction Line
WC	Rocker Arm Shaft Bracket Screw	XV	Center Upper Main Bearing Shell
WD	Rocker Arm Shaft Locating Screw	XW	Center Lower Main Bearing Shell
WE	Rocker Arm Shaft End Screw	XX	Center Bearing Cap
WF	Rocker Arm Shaft	XY	Exhaust Manifold
WG	Rocker Arm Spacing Spring	XZ	Exhaust Manifold Gasket
WH	Rocker Arm Shaft Bracket	YA	Cylinder Head Cover Lock Washer
WI	Rocker Arm Shaft End Spring	YB	Cylinder Head Cover Screw (Long)
WJ	Cylinder Head Nut	YC	Rocker Arm Adjusting Screw
WK	Exhaust Valve	YD	Rocker Arm Adjusting Screw Nut
WL	Valve Guide	YE	Rocker Arm
WM	Intake Valve	YF	Rocker Arm Ball Joint Cup
WN	Piston	YG	Valve Spring Seat
WO	Piston Ring, Compression	YH	Valve Springs (Inner and Outer)
WP	Piston Ring, Oil Regulating	YI	Air Intake Manifold
WQ	Piston Pin	YJ	Air Cleaner
WR	Connecting Rod	YK	Aperture Plug Retainer Nut
WS	Bellhousing	YL	Aperture Plug
WT	Flywheel	YM	Fuel Nozzle Valve
WU	Rear Upper Main Bearing Shell	YN	Fuel Nozzle Holder Assembly
WV	Flywheel Dowel	YO	Connecting Rod Piston Pin Bushing
WW	Rear Lower Main Bearing Shell	YP	Fuel Injection Line
WX	Flywheel Screw	YQ	Governor Breather Cap
WY	Connecting Rod Stud Nut	YR	Governor Stop Lever
WZ	Rear Main Bearing Cap	YS	Check Valve
XA	Cylinder Head Cover	YT	Fuel Injection Pump Breather
XB	Cylinder Head Cover Screw (Short)	YU	Fuel Transfer Pump
XC	Cylinder Head Cover Gasket	YV	Fuel Injection Pump Bracket
XD	Cylinder Head	YW	Pressure Regulator Assembly
XE	Cylinder Head Gasket	YX	Main Bearing Cap Nut
XF	Cear Cover	YY	Oil Pan
XG	Camshaft Gear	YZ	Oil Pump Pressure Line
XH	Camshaft Gear Chain Sprocket	ZA	Oil Filter Vent Cock
XI	Camshaft	ZB	Oil Filter Assembly
XJ	Front Upper Main Bearing Shell	ZC	Oil Filter Drain Plug
XK	Crankshaft Gear	ZD	Valve Push Rod
XL	Crankshaft	ZE	Valve Tappet Cover
XM	Gear Cover Oil Seal	ZF	Valve Tappet Guide
XN	Front Lower Main Bearing Shell	ZG	Valve Tappet
XO	Oil Pump Drive Gear	ZH	Bayonet Gauge
XP	Front Main Bearing Cap	ZI	Bayonet Gauge Bushing
XQ	Oil Pump	ZJ	Oil Pump Scavenging Discharge Line
XR	Intermediate Upper Main Bearing Shell	ZK	Oil Strainer
XS	Intermediate Lower Main Bearing Shell		





Reference WA to XX

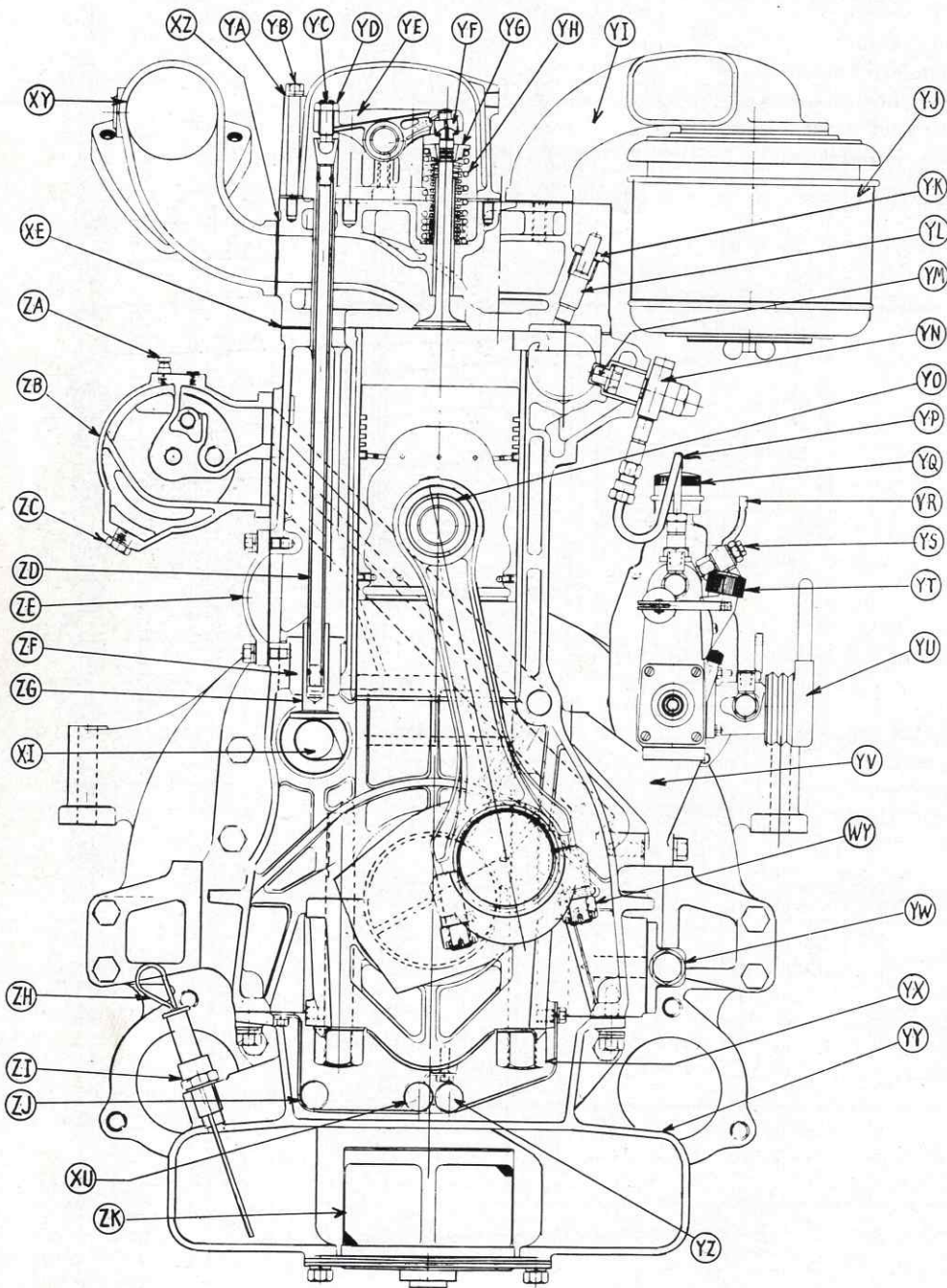

7. Remove the large slotted head screw, F Illustration No. 19, in upper part of governor plate. Remove inspection cover, A, Illustration No. 20 and block up tappets, B, with holders, C, Illustration No. 20. Remove the four screws, F, Illustration No. 20, holding governor plate to pump housing. Remove end plate, D, and gasket, E Illustration No. 20.

To Install Mechanical Governor

1. For assembly to injection pump, the plate must be removed from the new governor.

2. Put new gasket on. Be sure control rod moves easily in and out of the pump. Fasten new governor plate to the injection pump, as it is dowelled to and must be used with the new governor. Start the four small screws F. Illustration No. 20, into the cam shaft end plate. Insert large head screw at top to locate plate. Tighten lower four screws first, then tighten large head screw. Peen small amount of housing material into slots of screws to prevent loosening.

3. Pull the pump control rod out to full stop position and replace the two small rollers on control rod end E, illustration No. 19.

4. Put the governor control lever in full open position C, illustration No. 19. Be sure governor housing gasket is in place.

5. Hold governor unit in one hand and carefully lower it so that the governor yoke slot D, Illustration No. 19, engages the control rod rollers E, Illustration No. 19. Be careful the two rollers do not drop out. Do not relift governor unit higher than necessary to start screws in the case.

6. Line up dowel pins with holes and start screws fastening governor to plate B, Illustration No. 19. Release control rod from full open position and tighten the screws holding the governor unit to the plate.

7. Be sure cam shaft key is in place. Engage the keys on the drive flange with the keyways of the drive gear, and at the same time be sure the keyway is lined up with the key in the cam shaft and push the coupling into the gear. Then put on the cam shaft nut and tighten. Turn pump and governor over several times to be sure there is no bind. Peen small amount of housing material into slots of all housing screws to prevent their loosening.

8. Fill governor base to level as shown by test cock with good grade of light lubricating oil.

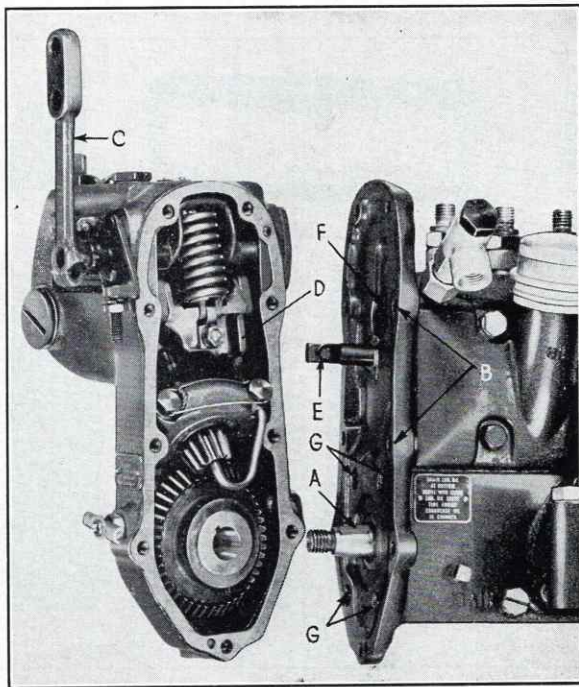

Illustration No. 19

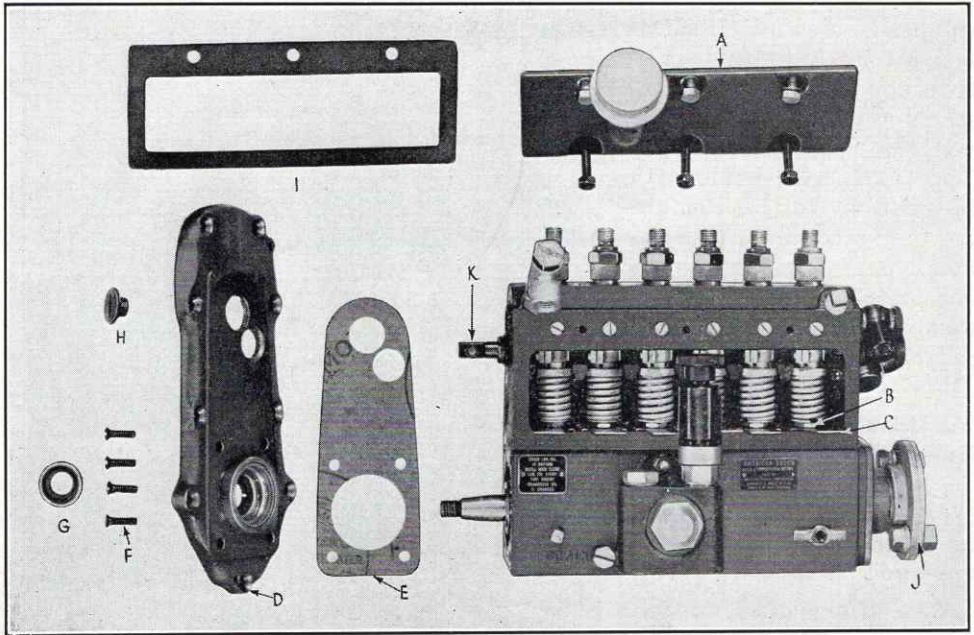

Illustration No. 20

Replacing Injection Pump on Engine

If engine has crankshaft set as in paragraph 3 in "Removal of Pump," page 47, the pump can be installed as outlined below. If engine has been changed, see section on page 24 for complete timing instructions.

1. Rotate pump coupling until cam lobe, for pumping unit nearest to coupling, is in vertical position, as it was when pump and governor assembly was removed. (See paragraph 3 in "Removal of Pump," page 47.)

2. Mount injection pump assembly on engine. If pump cam shaft and engine crankshaft are in same position as when pump was removed the two halves of the coupling will line up and slip together easily. When pump mounting bracket has been left on pump no lining up will be necessary. If pump was removed from mounting bracket it must be lined up so coupling will run true and free before tightening down the bracket.

3. Attach all high and low pressure fuel lines to injection and supply pump. Be sure these lines and fittings are **clean** and that all joints are tight.

4. Attach equipment control rod to governor lever.

5. Open check valve connection in injection pump and pump priming pump until clear fuel flows from this fitting.

6. Start engine and let air clear out of high pressure lines. Check for air at filter bleeder cock and injection pump housing.

How to Adjust Governor

1. Start the engine and slowly warm up.
2. After the engine is warm, the no load high speed may be set by the screw 20, Illustration No. 4. This speed should not be over 1800 to 1900 R.P.M. Screwing the set screw to the right decreases the speed. Be sure to lock the set screw with the nut after the speed is set and sealed.
3. This governor may be idled at nearly any speed from 400 R.P.M. up. The equipment control rod stop should be adjusted to the proper position for the desired idle speed. Adjust the idle spring to obtain a smooth idle 16, Illustration No. 4. To shut off the engine, pull the lever as far counter-clockwise as possible.
4. The governors are tested at the factory and should be set properly. If the over-run of the governor is not what is wanted, or if engine surges badly, it may be adjusted by the thrust sleeve, Illustration No. 17, as follows:

Remove the governor adjusting hole plug M, Illustration No. 21, rotate the governor thrust sleeve, Illustration No. 17, with a small screw driver until hole A can be seen through the governor adjusting hole. Insert the screw driver in the hole and move the locking sleeve B toward the bearing ring D until the tongues of the locking sleeve are free of the slots F of the adjusting nut E. Hold locking sleeve B in this position and with another small screw driver, rod or ice pick, rotate the adjusting nut E to the desired position. Then release the locking sleeve B, making sure the tongue C engages one of the notches in the adjusting nut F to lock adjustment. The adjusting nut D works on a right hand thread on the sleeve G and moving the notches of the adjusting nut clockwise past tongue C of the locking sleeve B shortens the sleeve, and counter clockwise lengthens the sleeve. Always note the original position of the sleeve and adjust two or three notches at a time until best operation is obtained.

INSTRUCTIONS FOR REPAIRING MECHANICAL GOVERNOR

To repair or replace worn or broken parts in the Hercules Mechanical Governor the following procedure will be helpful.

DISASSEMBLING THE GOVERNOR:

(All Illustration References are to Illustration No. 21 unless otherwise stated)

1. Remove injection pump and governor from engine and remove governor from pump as described on page 47.
2. Remove the idle spring and adjusting screw G.
3. Remove the high speed spring retainer nut and lockwasher A, then the spring link from the stud; remove pin B. Also remove pressed steel retainer for pin from the stud.
4. Loosen the clamp screws and remove the control shaft lever and shaft stop C. (Note lever positions as different installations have different levers as well as these levers being placed in different positions. It is necessary that the lever be replaced in the same position as when removed in order

to hook up to equipment control correctly.) Remove shaft bushings D. To remove control shaft F, allow yoke L to move inward as far as possible, rotate control shaft until the part connected to spring is

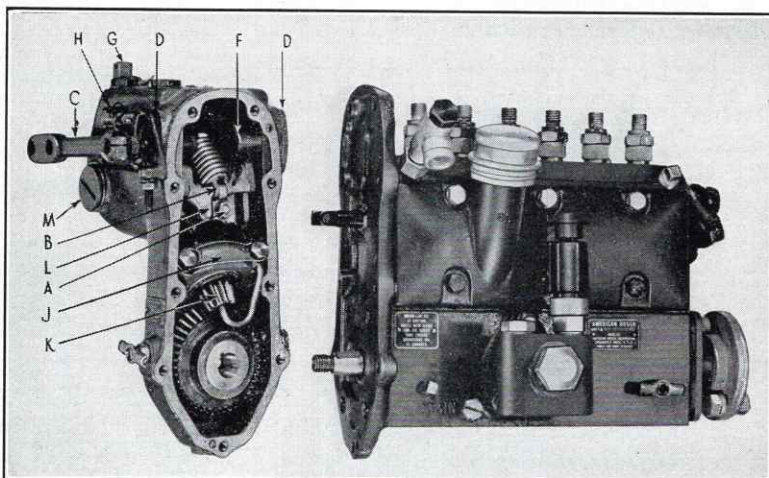

Illustration No. 21

projecting at right angles to the face of the housing. Slide the control shaft sideways in the housing until the short end clears the housing, then tilt the shaft and withdraw it.

5. Remove cotter, nut and washer from yoke shaft H and remove yoke shaft from opposite side of housing.

6. Remove screw and oil tube, also nut from stud and remove pinion shaft bearing cap J. It may be necessary to tap cap lightly to loosen it. Pinion shaft K now may be lifted up and out of housing together with yoke. It may be necessary to pry the shaft slightly to release lower bearing cap. Be careful not to damage bearing mounting machined surfaces.

7. Remove gear and thrust washer R and J, Illustration No. 22.

8. The pinion shaft upper bearing cup and adjusting cap S and WW, Illustration No. 22, are a sliding fit and easily removed.

9. The hub oil seal T can be pried out with a screw driver if necessary to replace.

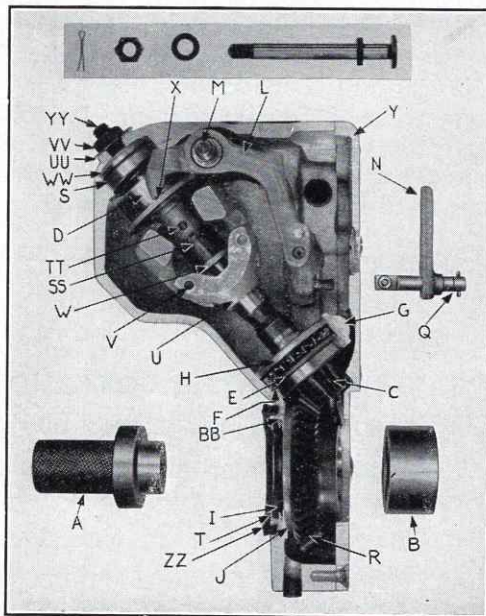

Illustration No. 22

INSPECTION OF PARTS:

(All Illustration References are to Illustration No. 22 unless otherwise stated)

Careful inspection will help in making correct and proper repairs.

1. The hub oil seal T must be in good condition and fit hub coupling

Replace this seal at every major overhaul.

2. Pinion shaft gear teeth C should not be broken, chipped or excessively worn.

3. Gear thrust washer J should be smooth and not scored. Should be of proper thickness for adjustment of back lash.

4. Pinion shaft bearings E and S should be in good condition and show no rough or rusted spots.

5. Pinion shaft assembly should be inspected as follows if gear was found in good condition under item 2.

(a) Shaft must be straight and not worn excessively by thrust bearing sleeve.

(b) Weight spider U must be tight on shaft.

(c) Weight pins V must be tight on spider.

(d) Weights must pivot freely but not be excessively loose on pins.

(e) Weight fingers must not be worn excessively, $\frac{1}{32}$ " radius on tip is normal.

(f) Oil passage through shaft must not be clogged. (Use air to check if open.)

6. Inspect yoke L for following:

(a) Bearings should fit yoke shaft M without binding.

(b) Curved surfaces X engaging thrust sleeve should not be excessively worn.

(c) Rack roller guide rivets must be tight.

(d) Sufficient lateral play of yoke to allow it to adjust itself to pump control rod and thrust bearing D without binding.

(e) Rack rollers should fit smoothly and be neither too tight nor too loose.

7. The loose washer W of the thrust sleeve assembly engaging weights should be smooth and flat. The thrust sleeve bearing should rotate freely and should be tight in the ring and on the sleeve.

8. The idle spring should be of proper length and not bent.

9. Check high speed spring and control rod for following, Illustration No. 23:

(a) Shaft not sprung to cause binding.

(b) Spring should not be stretched, coils should be tight together.

(c) Spring pins should not be excessively worn.

10. Inspect housing for mechanical damages such as stripped threads, cracks or gouged sealing surfaces.

11. All seals and gaskets should be replaced.

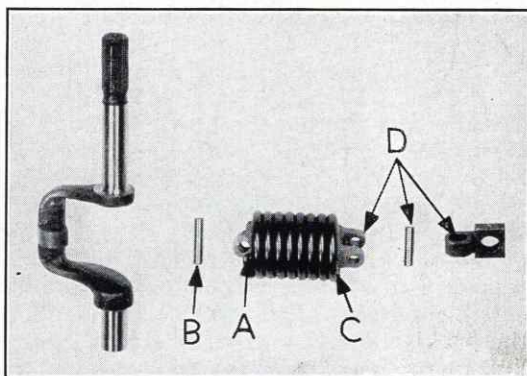

Illustration No. 23

ASSEMBLING GOVERNOR:

After parts have been inspected and all worn or defective ones renewed, the following procedure will help in assembling the governor.

1. Be sure all parts are thoroughly cleaned and lubricated.
2. If gear, gear washer, pinion shaft or housing have been renewed, it will be necessary to check the adjustment of the gears and the pinion shaft bearings. The proper adjustment of the gear teeth is .003" to .006" backlash. To check the backlash, insert plug A in oil retainer ring bore BB, Illustration No. 22, and assemble the gear and thrust washer in the housing and support on the small diameter of plug A. Place the pinion shaft assembly C in the housing and tighten the bearing cap. The thrust sleeve assembly D may be omitted for present. The flange of the pinion shaft lower bearing cup D must be firmly and squarely seated on the housing F. The oil impeller cup H should be pushed up on the shaft and not clamped for this check. With the shaft now in place check the clearance between the gear teeth with a feeler gauge or piece of shim stock. The backlash is adjusted by selecting a gear washer J of suitable thickness. (These washers are obtainable in six different thicknesses.) For this purpose an increase in thickness of .002" decreases the backlash .001" and vice-versa. The ends of the teeth of the gear should line up with the ends of the teeth on the pinion within .010". The pinion shaft should have .001" to .004" end play obtained by adjusting screw YY at the upper pinion shaft bearing. Be careful with this adjustment.

3. When proper backlash adjustment has been obtained, the assembly can be completed. Remove the pinion shaft, replace the yoke L in the housing, place the thrust sleeve assembly on the pinion shaft and replace the pinion shaft in the housing. Be sure to include washer W next to the weight fingers. Insert yoke shaft M with the soft gasket in place in the recess in housing under both yoke shaft head and nut. Tighten yoke shaft nut against housing and secure with cotter pin. Do not tighten so tight as to deform housing and cause binding of other parts and maybe oil leakage. The pinion bearing cap G should be tightened with oil impeller cup in place and screw and stud nuts secured with wire. The oil impeller cup must be aligned properly to avoid pinching and must not ride the impeller. Seat the impeller cup against shoulder in housing and cap.

Check pinion shaft bearing end play adjustment (.001" to .004") and tighten check nut VV. Recheck end play after tightening nut and if correct, bend one ear of washer UU down against housing and one ear up on side of nut to lock.

4. If high speed spring assembly, Illustration No. 23, must be renewed, unscrew the spring at the control rod end A sufficiently to remove pin B. To install the new spring assembly, connect the new spring assembly to the control shaft with the pin and screw the spring on to the link about $\frac{1}{4}$ turn so that the spring prevents the pin falling out. Do not disturb the spring on lower link C. Be careful not to scratch or gouge spring. The slot in the lower link must be at right angles to the control shaft. Reassemble control shaft in housing.

5. Connect high speed spring assembly and link D, Illustration No. 23, to stud on yoke L, Illustration No. 22.

6. Replace the hub oil seal T, Illustration No. 22 (Lip of seal I must point toward governor gear); also replace the hub dust seal ZZ.

FILTERS

7. Replace the idle spring in the socket in the yoke and screw in the idle adjusting screw about halfway.

8. Attach yoke travel fixture N, Illustration No. 22, to the flange of the governor with the pin or roller of the fixture inserted in the square hole in the rack roller guide of the yoke L. Insert sleeve adjusting wrench at M, Illustration No. 21, and adjust the length of thrust sleeve, Illustration No. 17, per instructions on page 53, until the line Q, Illustration No. 22, on the rod of the fixture N is flush with the face of the boss with the governor weights in wide open position.

9. Reassemble plate Y to pump and governor to plate per instructions on page 51.

10. Fill with clean oil to proper level, assemble pump assembly to engine, start engine and make adjustments as outlined on page 53. With engine running at idle speed of about 400 R.P.M. remove plug M, Illustration No. 21, and observe if any oil is being thrown off by the weights. Evidence of a small amount of oil indicates oil system is functioning properly.

NOTE: If a new governor housing has been used without using a new governor plate, or vice-versa, it is advisable to check the alignment of the two housings. This can be done by fastening the governor housing to the plate, inserting plug A, Illustration No. 22, as described previously and then inserting plug B in the bore of the governor plate and allowing the pilot on A to engage the bore in B. Plug B must rotate freely. It may be necessary to relocate the dowels to eliminate binding.

FILTERS

(Air, Fuel Oil and Lubricating Oil)

Since dirt is the greatest enemy of any internal combustion engine, it is necessary to take every precaution to exclude it from the engine. To help keep this dirt out of your Diesel engine the Hercules Motors Corporation has installed the type of filters which they have found by experience to best fulfill the various requirements of their engines. However, these filters cannot continue to keep the engine clean internally unless given intelligent care and serviced frequently. On each filter there appears an instruction plate which if followed will help in servicing these engines. In the following paragraphs we take up each of these filters separately; air, fuel oil and lubricating oil. (Certain special filter installations are not covered in this book.)

AIR FILTERS OR CLEANERS

The oil bath type air cleaner and filter is one of the most efficient and yet the easiest to clean and service. These units should be cleaned at least once a day or if working in very dusty conditions should be cleaned every six or eight hours. To clean the type commonly supplied, remove the screen element and shield by unscrewing the long screw with the knurled or winged hand nut. Wash this unit in clean kerosene, fuel oil or gasoline. If compressed air is available, blow dry, blowing from inside to outside. If after first washing it still appears dirty wash again and repeat until clean. Lay this unit after it is clean on a piece of clean paper. Next remove outside lower shell which holds the oil, clean old oil and dirt by washing with clean fuel oil, kerosene or gasoline. Some of the units have a baffle plate in the bottom; remove this before cleaning as most of the dirt will be found under this plate. Wipe dry with a clean cloth. Fill with clean lubricating oil up to oil level bead.

Before installing inspect gasket and if torn or broken, replace. Now dip the screen or unit in clean lubricating oil and install. This operation is essential since this unit if uncoiled will absorb the oil from the lower unit thus reducing the amount of oil to a point which efficient air cleaning action is no longer available.

FUEL OIL FILTERS

Because of the extremely accurate construction of the various parts of the fuel injection system and since repairs to these units are quite expensive, the Hercules Motors Corporation has worked out an elaborate filtering system which with intelligent care will reduce the wear on the accurately fitted parts of the injection system. This filtering system contains the following filters:

A dual, special metal unit, filter between the fuel tank and the fuel transfer pump. (Some automotive installations have a similar filter mounted in the bottom of the fuel tank.) This unit is to remove the larger particles of dirt and water and some are equipped with a knife cleaner.

A metal and cloth combination final filter is installed between the fuel transfer pump and the fuel injection pump; this unit is shown in Illustration No. 24. (Mounted on another series of engines, not DFX.)

On some installations the final filter is of the sealed type instead of the metal and cloth combination. Units having this type of filter are generally equipped with a pressure gauge and the entire filter unit should be replaced with a new one (which should be carried in stock) when the pressure gauge hand remains in the red division of the gauge, which is usually less than five pounds. On units not equipped with a gauge, replace the filter when engine power falls off due to clogging of the filter and insufficient fuel reaching the fuel injection pump manifold.

In addition to these filters, each fuel nozzle has a stem filter shown as 1 in Illustration No. 6. The cleaning of this filter is covered under section about the care of nozzles.

TO CLEAN FUEL FILTERS

The dual filter which is equipped with a cleaning knife should have the turning handles on top turned once a day; this wipes off the largest pieces of dirt and drops of water which have been caught on the element. Once a week the drain plug at the bottom of each case can be removed and this dirt allowed to flow out. After turning handle, check the packing nut around the stem, making sure it is tight.

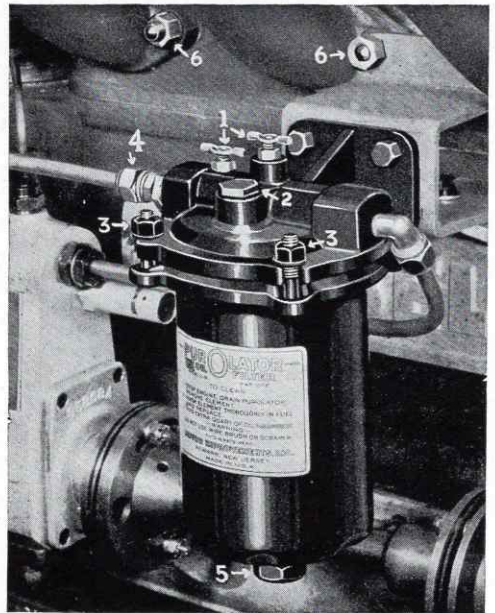

Illustration No. 24

To reduce the amount of cleaning the filters should receive, insist on the fuel oil being clean and then handle it with clean containers. The filter unit should be removed every week or 100 hours operation and washed in clean gasoline, kerosene or fuel oil, since this unit is constructed with very fine spacing between the brass strips. Do not use a wire brush or hard instrument to scrape sludge but wash with a clean cloth or soft bristle brush. Frequency of cleaning is determined by the amount of dirt and gum or wax in the fuel oil.

The final filter shown in Illustration No. 24 which is between the fuel transfer pump and the fuel injection pump contains a metal element surrounded by a fabric element. To clean, remove case, cloth unit, also metal unit. This cloth unit is equipped with a bayonet catch which is turned to right to release; the metal element is screwed into the head casting. Wash metal unit with cloth in clean gasoline, kerosene or fuel oil. Do not use any hard or sharp tool to clean this unit as damage will result. The fabric element may be washed in the same cleaning fluid but care must be taken to see that all the gum and dirt is washed out of the fabric. Since certain fuels attack the fabric and cause it to deteriorate, it may be necessary to replace this unit with a new one from the spares. After cleaning reassemble, reversing the procedure.

Alcohol is a good cleaning agent where gummy or wax forming fuels are encountered.

This filter will in all probability require more frequent cleaning than the dual filters due to the cloth element removing a large part of the gummy residue in the fuel oil.

Some specialized installations may have a different fuel filtering system but the above will also serve as a guide in maintaining a clean fuel system. Since dirty fuel filters affect the efficiency of the engine, it is necessary to keep them clean for low cost operation.

LUBRICATING OIL FILTER

The lubricating oil filter shown in Illustration No. 25 consists of two elements, No. 2 and No. 3 (also shown being pulled apart in Illustration No. 26), enclosed in shell No. 1. These filtering or straining elements should be cleaned very frequently, an exact schedule cannot be definitely established due to its being influenced by the kind of oil used and the particular duty

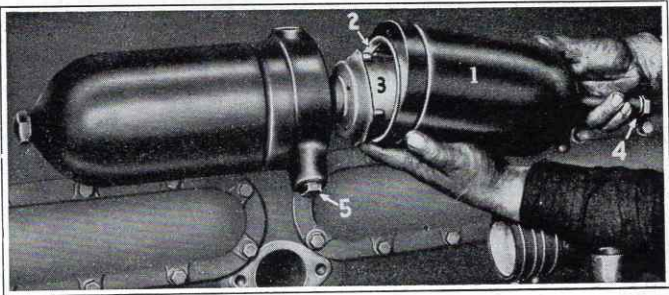

Illustration No. 25

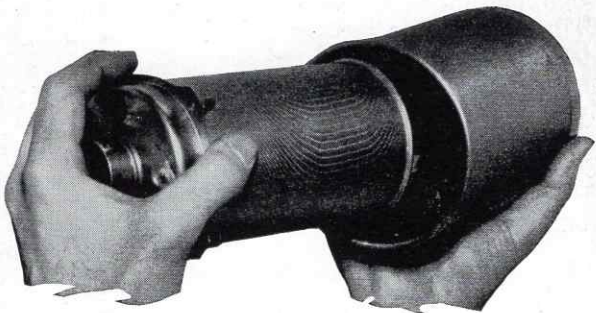

Illustration No. 26

demand of the engine. We would suggest removing the shell and elements at least twice a week for cleaning and from the condition of the elements a schedule can be established to best meet any particular operating conditions.

To clean, remove shell, then elements, pull elements apart as shown in Illustration No. 26. Wash in clean gasoline, fuel oil or kerosene using a clean cloth or soft bristle brush. Do not use wire or hard bristle brush or scraper, as these harsh methods will ruin the elements.

Frequently remove plug No. 5, Illustration No. 25, and allow the dirt, water and sludge which has accumulated to drain out of the filter.

Remember, any type of filter (air, fuel oil or lubricating oil) must be given intelligent attention and frequent cleaning if it is expected to remove dirt, etc. Some filters must be inspected and cleaned daily. Study the service requirements of your particular operation and save repair expense.

GENERAL DESCRIPTION AND MAINTENANCE

The "DFX" series of Hercules Diesel engines is of the four stroke cycle type having six cylinders with a valve mechanism of the overhead type and with the cylinder block and crankcase cast integral. This series has four models of engines differing only in size of bore: the DFXB-5", the DFXC-5¼", the DFXD-5½", DFXE-5⅝", and the DFXH-5¾", the stroke being the same, 6". The crankshaft is supported on 7 large main bearings with a diameter of 4½".

The general construction of the engine tends to produce a very rigid unit, since crankcase and cylinder block are in one piece; this results in maximum rigidity and minimum weight. In order to secure the high compression necessary for Diesel operation, the valves are located in the cylinder head.

Crankcase and Cylinder Block: The combination of cylinder block and crankcase in one piece permits carrying the water jacket the full length of the cylinder bore. This results in uniform cooling of the piston and cylinder wall and has a very definite bearing upon maintenance of lower oil temperatures than is possible with any other type of construction without the use of oil coolers. The most casual inspection of the cylinder block will disclose the rigid construction provided to support the main bearings and crankshaft, and this rigidity coupled with the extremely large diameter of the crankshaft results in a very smooth running engine, free from destructive vibration, even at the higher speeds.

Illustration No. 27 gives the relation of various parts as shown from the top. No. 1 is the lower combustion chamber liner, No. 2 is the upper combustion chamber liner, No. 3 is the dowel which locks the

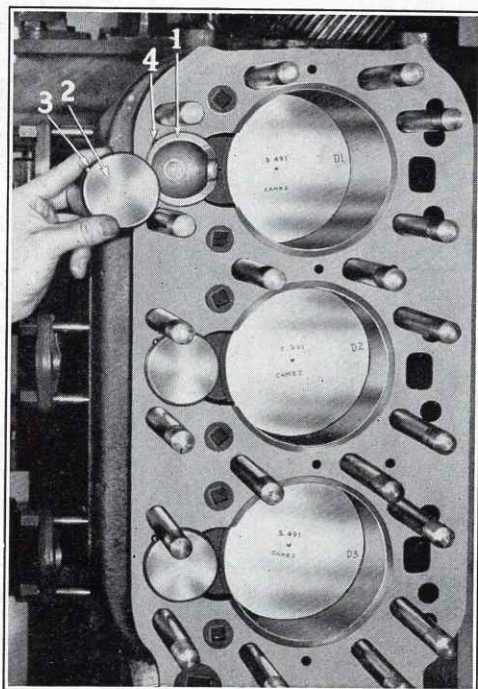

Illustration No. 27

liner in block at provision No. 4 so that it cannot turn and block the opening.

Main Bearings: Main bearings are of the removable shell type—in both the crankcase and the bearing caps. Replacement shells are not machined after installation in the case. Therefore, replacement of bearings becomes a very simple matter. See Illustration No. 28 which shows the bottom view of the engine and the bearing caps in place.

The bearing shells are locked against rotation by means of a small ear or projection on each shell at the split line. Various types of alloy metals are used in the manufacture of these bearing shells. These alloy metals are harder than tin base babbitt, and some additional bearing clearance must be provided. It is, therefore, recommended that .005" to .006" clearance be provided between the crankshaft and the main bearings. The main bearing caps are very rigid castings and are securely fastened to the crankcase by means of large diameter studs, two studs being used for each bearing. The main bearings are doweled in place so as to permit removal of caps and replacement without shifting bearings on the case.

Main Bearing Adjustment:

If excessive clearance develops between shaft and bearing shells, bearing fits are reconditioned by use of new shells. If clearance is excessive, regrind shaft and use undersize bearing shells. After readjustment of the bearings and their caps having all been tightened securely, it should be possible to turn the crankshaft in the bearings by taking hold of the cheeks of the shaft. Care must be exercised to prevent too tight a fit on any of these bearings. Refer to table of clearances on page 84.

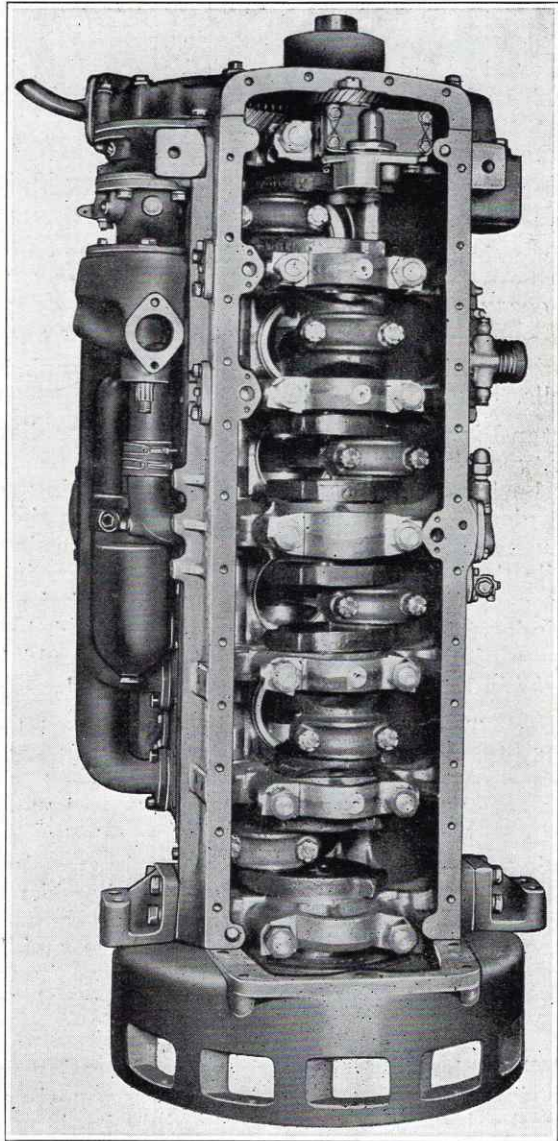

Illustration No. 28

Connecting Rod: The nominal diameter of the connecting rod journal is $3\frac{3}{16}$ ". The connecting rod bearings are of the precision shell type, and the bearing metal used is of various types of alloy metal. Shims are not commonly used between the connecting rod and the cap. The shells are held in place and rotation is prevented by means of an ear on the shell at the split line. The connecting rod is drilled, permitting oil to pass from the big end bearing up to the piston pin. Illustration No. 29 shows the connecting rod and its various parts.

Caution: When removing piston and connecting rod from the cylinder bore the carbon which has collected at the top of the cylinder bore may make it necessary to use considerable force to push the piston out of the cylinder. Removal of the carbon around the top of the bore will make piston removal much easier. In order to prevent scratching the cylinder bore while forcing the piston and rod assembly out, it is advisable to either wrap the lower end of the connecting rod with a rag or place two strips of thin wood or cardboard between the rod and cylinder wall. Then if the rod rocks it will not gouge or scratch the cylinder wall.

Connecting Rod Bearing Adjustment: Due to absence of shims adjustment of connecting rods is made by replacement of the bearing shells. A clearance of .0035" to .0045" is recommended between the connecting rod journal and the connecting rod shells. Should wear of journal cause this clearance to be more, then it is necessary to regrind the crankshaft and use undersize bearing shells.

Piston Pin: The piston pin is of very large diameter, and is of the full floating type. This means that the pin can rotate in either the piston bosses or in the bushing at the top end of the connecting rod, but the fit in the piston is intended to be much tighter than the fit in the connecting rod bushing; consequently the movement in the piston consists of a slight creeping action, while the normal rotation of the pin occurs in the bushing at the rod. The piston pin is prevented from moving endwise and making contact with the cylinder wall by means of snap rings which lock in grooves machined in the bosses of the piston. The piston pin should have a clearance of .0015" to .0025" in the bushing in the top of the rod.

Piston. The piston is made of a very special aluminum alloy and is of the solid type, having no saw slots or split in the skirt. Six piston rings are used, the upper four rings being of the compression type, while the 5th ring from the top which is above the piston pin and likewise the ring located near the bottom of the skirt are of the oil regulating type. The top of the piston is made very thick in order to uniformly transfer the heat from the top of the piston to the various rings and into the skirt of the piston where it can be dissipated in the water jacket without any of the piston rings becoming extremely hot, which condition tends to rapidly destroy lubrication of such parts. The top ring is located well below the top of the piston to prevent its becoming too hot. This tends to eliminate the sticking of piston rings. Illustration No. 29.

When checking piston rings consideration must be given to the fact that the rings are not as tight in the grooves when the piston is hot, and consequently rings which seem to be tight in the groove after engine has been in operation for a considerable period of time may in reality be loose enough to function properly when the engine is heated up. The appearance of the con-

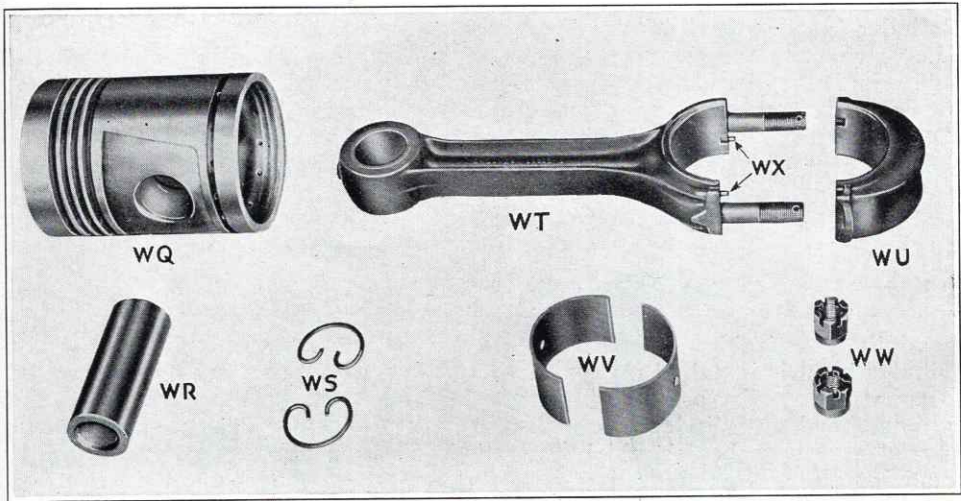

Illustration No. 29

tact surface of the rings will usually show whether the ring has been functioning.

Ring Gap and Groove Clearance. The piston rings when fitted to the bore of the engine should have a gap clearance between .018" and .022". The top ring should have from .0035" to .004" land clearance while the other rings should have from .0015" to .003" land clearance.

Piston Clearances.

	Min.	Max.
Piston Clearance in Cylinder Bore—DFXB	.008"	.0085"
Piston Clearance in Cylinder Bore—DFXC-DFXD-DFXE	.0085"	.0095"
Piston Clearance in Cylinder Bore—DFXH	.014"	.015"

The above clearances are obtained by measuring the piston diameter at the skirt or near the bottom of the piston with outside micrometers and measuring the cylinder bore diameter with inside micrometers. If feeler ribbon is used, this should be a ribbon of .008" thickness for the DFXB and DFXC, .009" thickness for the DFXD and DFXE and .018" thickness for the DFXH. The ribbon used should be 1/2" wide and it should be possible to pull out the ribbon with four to five pounds pull.

Combustion Chamber. The combustion chamber into which the air is compressed at the end of the compression stroke is located at one side of the cylinder bore, and is lined with two removable sections—one spherical shaped, which is located in the portion of the combustion chamber machined in the cylinder block while a cover section extends up into a recess in the cylinder head.

When any of these parts are replaced, care must be used in replacing the cylinder head to make sure that the head does not rest on top of the combustion chamber liner, preventing the head being drawn down tight on the gasket. If this condition should be found to exist, file off a portion of the top of the upper liner. The spherical section has a lip which is directly opposite the hole in the line through which the injection nozzle is located. These various items are shown as No. 1 and No. 2 in Illustration No. 27.

Cylinder Head. Two cylinder heads are used, one for each three cylinders. The valve seats and the valve guides are a part of this casting, although the valve guide bushings are removable. The heads are held to the cylinder block by a very large number of strong studs, and in order to insure against leaks the heads must be carefully drawn down by means of the stud nuts which should be progressively tightened, working from the center of the head towards the ends and sides.

A wrench approximately 18" long should be used for this operation, preferably a tension type wrench. See page 85 for recommended tensions.

Cylinder Head Gasket. The cylinder head gasket is made of solid sheet copper which is carefully annealed in order to make the copper as soft as commercially practicable. When the gasket is placed on the cylinder, or the cylinder head is installed on top of the gasket, great care must be exercised to prevent any dirt or foreign matter lodging between the gasket and the cylinder head or cylinder block. If the gasket becomes deeply scratched or marred a new gasket should be installed. Clean a used gasket thoroughly, removing all carbon and sealing compound before putting it on engine. When installing use a plastic sealing compound to insure a leakproof installation.

Valve Mechanism. The valves being located in the cylinder head are operated by conventional type tappets with hollow push rods running from the tappets to the rocker arms. The rocker arms are lubricated by means of oil forced through the hollow shaft on which they rotate. Oil is forced out through small holes in the rocker arms to the special ball cup over the valve stems. A clearance of .016" should be maintained between rocker arm and exhaust valve stems and .010" between rocker arms and inlet valve stems. The clearance between valve stems and valve guides when new is approximately .0025" to .003". See clearance table, Page 84.

Valve Grinding. If proper fuel oil, lubricating oil and air cleaners have been used, and cared for, and proper clearances have been maintained between valve stem and rocker arm, valve grinding will be necessary very infrequently. Their seating should be tested periodically by rocking the engine against compression. When the engine will not rock, compression is leaking through either the valves or cylinder head gasket or past the rings. Check the leak by listening for a "hissing" sound, when the engine is cranked by hand, either at the cylinder head gasket or in the crankcase breather. If at cylinder head gasket, remove head and replace gasket. If in the breather, dismantle engine and install new parts for those found worn or scored. If no "hissing" is heard at either of these two places, remove head and valves, clean both thoroughly, removing all carbon and oil. Inspect valve seats and valves.

If deep pits are found either replace valves with new, or reface old, reseat seats with a vibrating 45° angle grinder type reseating tool similar to that shown in Illustration No. 30. Because of the large diameter and surface of the valve seats it is very difficult to obtain a good reseating job with a reamer type tool. Remove all shoulders and pits from the seat but do not grind any deeper than necessary. Then finish the new, or refaced valve, to the resealed seat, by hand in the usual manner making the same tests for seating.

If the valves and seats are not deeply pitted or shouldered, obtain a light spring with tension enough to just hold the valve off the seat. Lubricate the valve stem and apply a thin coating of good quality medium coarse grinding compound on the valve face. Insert the valve in the valve guide and rotate the valve back and forth about a quarter of a turn a few times pressing firmly on

the grinding tool. Release the pressure on the tool and the spring should lift the valve from its seat. Rotate the valve 15° or 20° and repeat the grinding process. It will probably be necessary to wipe off and inspect the valve and seat during this process to see what progress is being made or the compound may wear off of the surfaces being ground. In either case reapply another thin coating of compound until the test shows the surfaces are in contact. Then wipe off all heavy compound and apply a thin coating of "fine" compound and continue the grinding. When the surfaces are "finished" make ten or twelve pencil marks equally spaced across the face of the valve and lightly rotate the valve in the seat. If all of the marks are wiped off the valve is properly seated. If any marks are left intact, keep on grinding until valve is properly seated.

When all valves are seated reassemble in head with springs and retainers. Turn head on exhaust opening side and pour gasoline in the intake openings. If any gasoline seeps out around valve remove that valve and regrind. Turn head over so the intake openings

are down and repeat the test pouring the gasoline in the exhaust openings. If any exhaust valves leak regrind.

Be sure to clean all grinding compound from valve seats and stems.

When valves are all properly seated and assembled install head on engine, install push rods and rocker arms and set valve clearances.

Start engine and run until properly warmed up. Tighten heads down again with engine warm. Then recheck and adjust valve clearances with warm engine.

Valve Tappet Assembly: Illustration No. 31 shows the arrangement of the valve tappets and guides in the side of the block. Each guide has a flange 3 which rests against the machined surface in the cylinder block casting and is held rigidly in place by a special retaining washer 4 and

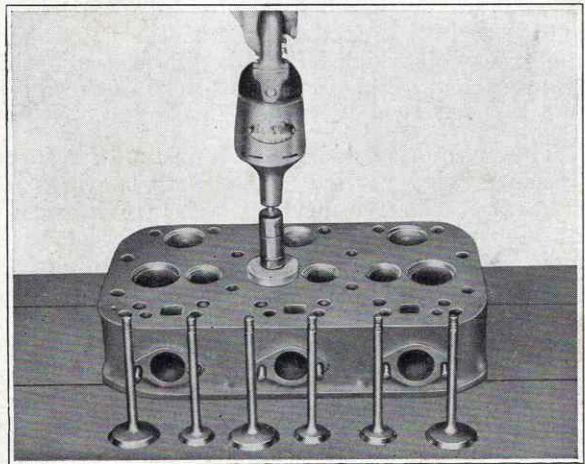

Illustration No. 30

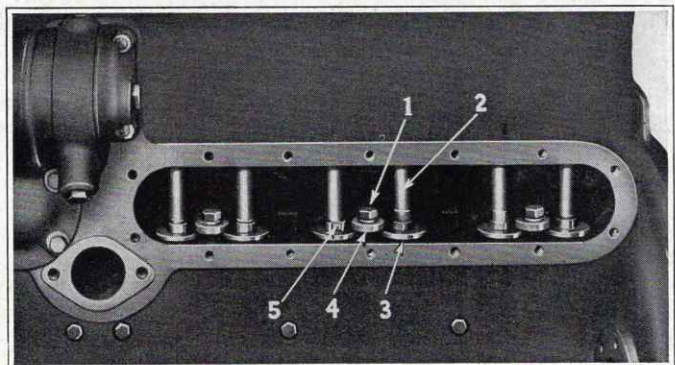

Illustration No. 31

screw 1. The tappets 5 are hollow to receive the pushrods 2 and can be readily removed without removing the camshaft as the mushroom end will clear the hole in the block provided for the tappet guide. To remove a tappet and guide it is only necessary, after the push rod 2 has been removed, to remove the screw 1 and washer 4 and lift out guide and tappet. This type of construction also facilitates the removal of the camshaft and gear assembly.

Lubrication System: There are two types of lubrication systems. One is the wet sump or conventional type wherein the oil is kept in the oil pan. The other is the dry sump where the oil is kept in a sump or reservoir outside the engine and is pumped from this reservoir into the engine lubrication system, the excess oil which falls into the oil pan is picked up by a scavenging pump and returned to this reservoir. Each of these types will be taken up separately in a later paragraph.

The engine is lubricated by means of a forced feed system with oil under pressure being carried to the main bearings through channels drilled in the crankcase. The connecting rods are lubricated by means of holes drilled through the crankshaft which holes register with the oil groove in the upper main bearing shell. The piston pins are lubricated by means of a hole drilled in the connecting rod and by the oil scraped off the cylinder walls into the bosses of the piston. The oil under pressure is also led to the rocker arms and valve compartment by means of suitable drilled passages in the cylinder block which register with one of the rocker arm shaft brackets permitting the oil to be carried to the hollow shaft on which the rocker arms rotate. The front cam bearing and the fuel pump drive shaft are lubricated by pressure. The cylinders and pistons, valve tappets and balance of the cam bearings are lubricated by oil thrown off from the connecting rods and main bearings.

The gears in the front compartment as well as the timing chain are lubricated by means of suitable holes through the front camshaft bearing and the fuel pump drive assembly; these drilled holes are metered by the rotation of the shaft in order not to overload the gear compartment with oil. These holes should be thoroughly cleaned every time the engine is overhauled. The use of good oil will eliminate any objectionable sludge which will be the only cause for trouble.

Oil Pump: The oil pump is the same on both the wet and dry sump type engines. The only difference is in the oil pump cover. The oil pump is of the gear type mounted on the front main bearing cap and driven by gear off of the crankshaft gear. The oil pump is shown disassembled in Illustration No. 32 which shows the four pump gears WK and pump drive gear WA along with other parts. Two of the pump gears WK are used for the scavenging side of the oil pump while the other two gears are used on the pressure side of the oil pump. To disassemble the oil pump remove cover WO then pull gear WA from shaft WJ removing key WG then removing cover WE. The gears with their respective shafts can then be pulled from the body WB. Since the oil pump is always well lubricated these parts seldom wear out if the lubricating oil is kept clean by intelligent care of the lubricating oil filters and by the use of a good grade of oil, therefore, the removal and disassembly of this oil pump should be very infrequent.

Wet Sump System: Illustration No. 33 shows the bottom view of the wet sump type system. The oil pan of the system has a capacity of 28 quarts and is equipped with a bayonet type gauge which should always be used in checking the oil level which should be maintained near the 4/4 mark on this gauge.

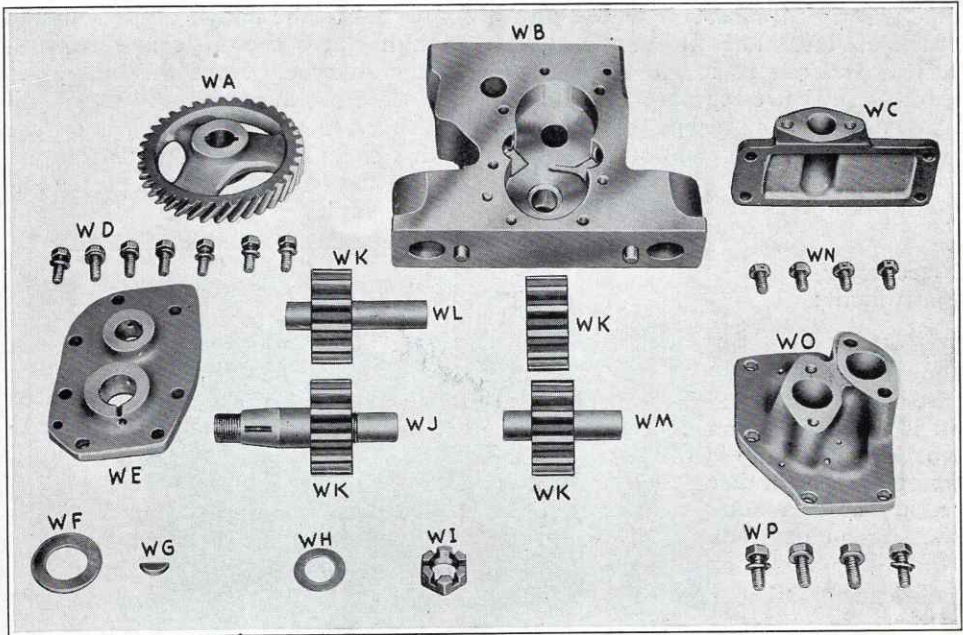

Illustration No. 32

Never allow the oil to fall below the $\frac{2}{4}$ mark. The main part of the oil sump which has the strainer screen mounted in it is near the rear of the engine. The oil pump pulls the oil from this sump through pipe 4 in Illustration No. 33 and delivers it under pressure through pipe 3 to the crankcase. A pressure regulator 6 mounted on the side of the crankcase regulates the pressure allowing any excess oil to return to the crankcase. This is discussed in a later paragraph. In order to prevent oil from collecting in the front part of the oil pan, as when the engine is going down grade, the scavenging part of the oil pump is covered by a screen 1 which allows this pump to pick up the oil and deliver it to the main sump through pipe 2.

Since all the oil lines are made up in one complete assembly no difficulty should be encountered in their removal and reassembly to the engine.

Dry Sump System: Since the dry sump system depends upon the oil supply being maintained outside the engine it is necessary that this supply be sufficient to allow for the oil required in the various filters and oil lines and should have ample capacity for reserve so that at no time the suction line to the pump is ever empty.

In order to give a complete picture of this oiling system three illustrations are shown, No. 34, No. 35 and No. 36, which show respectively the bottom view of the engine and views from either side so the various oil lines used on this system can be seen. (In all cases the same reference figures appear.)

Since the oil pan acts primarily as a catch basin for oil thrown off by the connecting rods and bearings so that it can be picked up by the scavenging pump and returned to the reservoir it is so constructed that all the oil drains to the center of the pan and is picked up by the scavenging pump through oil pipe 2 after being pulled through strainer 1. It is then delivered through oil

pipe 4 to the oil reservoir whose pipe is connected to the flange on the outside of the engine. The oil pump picks up through pipe 3 the oil from the oil reservoir and pumps it through pipe 5 to the crankcase. Here the oil passes through pressure regulator 9 which regulates the pressure and any excess oil is bypassed through pipe 6 and connection 7 back into pipe 3 which is on the suction side of the pump and recirculates this excess oil (sometimes this excess oil is bypassed into the line going back to the oil reservoir). The regulation of the pressure is discussed in a later paragraph.

Viscometer Instrument:

This instrument shown as 5 in Illustration No. 33 and as 10 in Illustration No. 34 and No. 36 is covered in another section of this book starting on page 16.

Lubricating Oil Filter:

The lubricating oil filter is shown in Illustration No. 25 and its care is covered on page 59 under "Filters."

Oil Pressure Adjustment:

The oil pressure should be regulated so as to maintain approximately 45 pounds at 1600 R.P.M. which should in about 38 to 40 pounds at 1200 R. P. M. This oil pressure is set at the factory and should not be judged to be too high or too low until the engine has been thoroughly run in and is up to operating temperature. (The oil should be at least 140° to 150° F.)

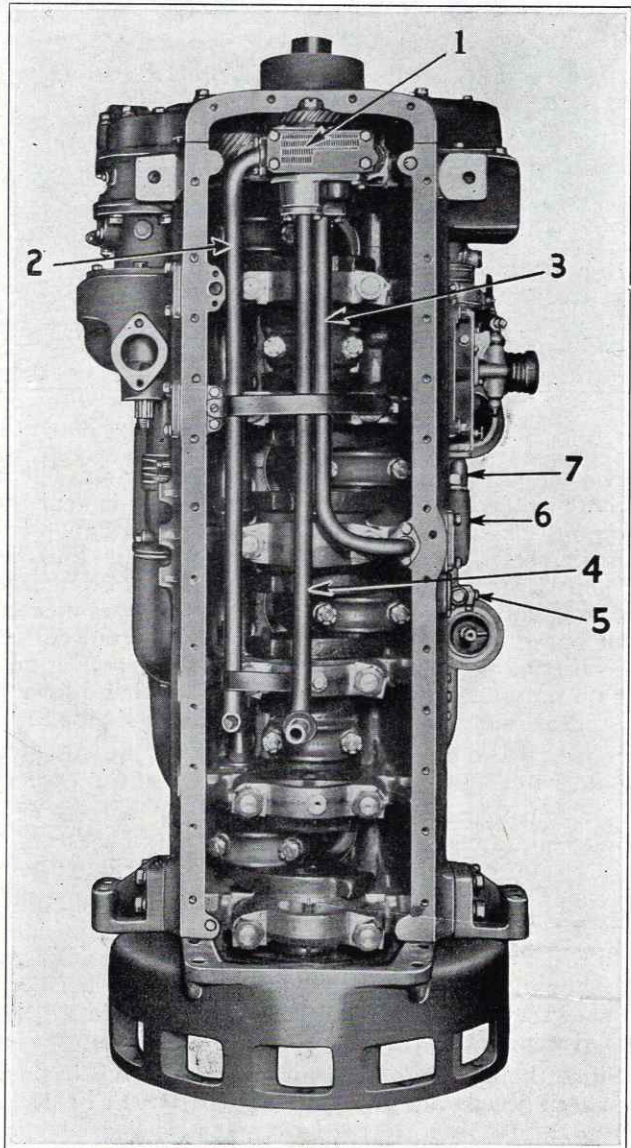

Illustration No. 33

GENERAL DESCRIPTION AND MAINTENANCE

To regulate the pressure on the wet sump system remove acorn nut 7, Illustration No. 33, and turn screw in to increase pressure and out to decrease.

On the dry sump system refer to illustration No. 36, removing acorn nut 8 and turning the screw in or out as required. If the pressure does not change, remove this adjusting screw and the spring and regulating piston in back of it, washing these parts as well as the regulator with fuel oil or kerosene, re-install these parts and try the pressure regulation again. If the pressure

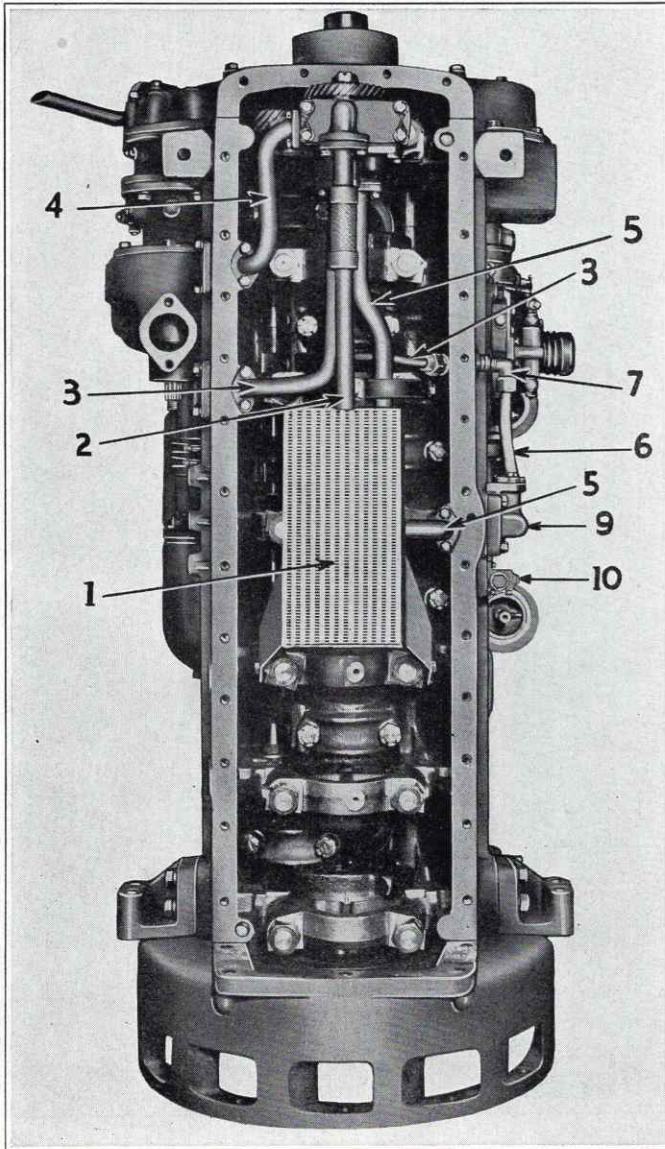

Illustration No. 34

shows no change, check oil pressure gauge, oil lines or bearings. A drop in pressure will sometimes occur as the engine begins to wear in or "free up" and no attempt should be made to readjust for this slight decrease in pressure as the oil being thrown off by the bearings and connecting rods is already over-oiling the cylinder walls.

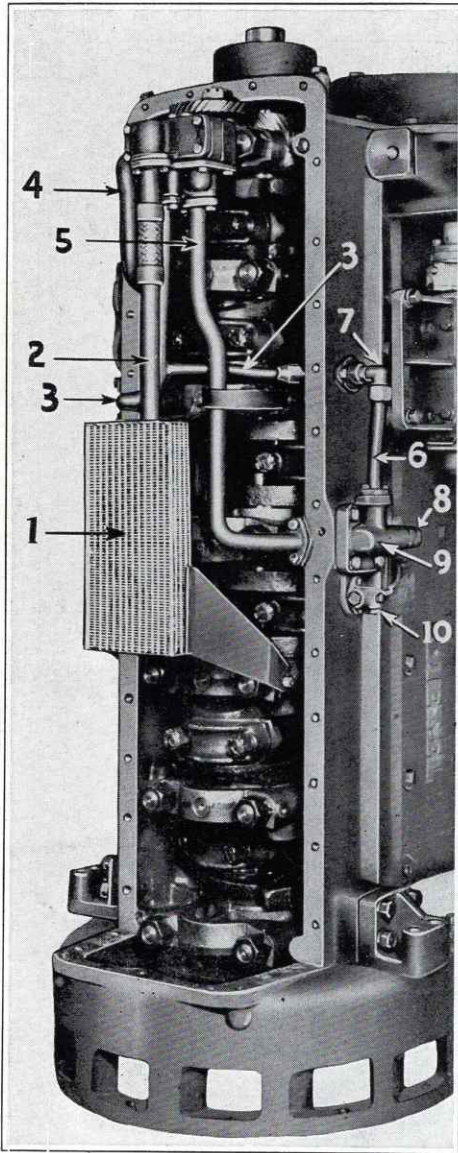

Illustration No. 35

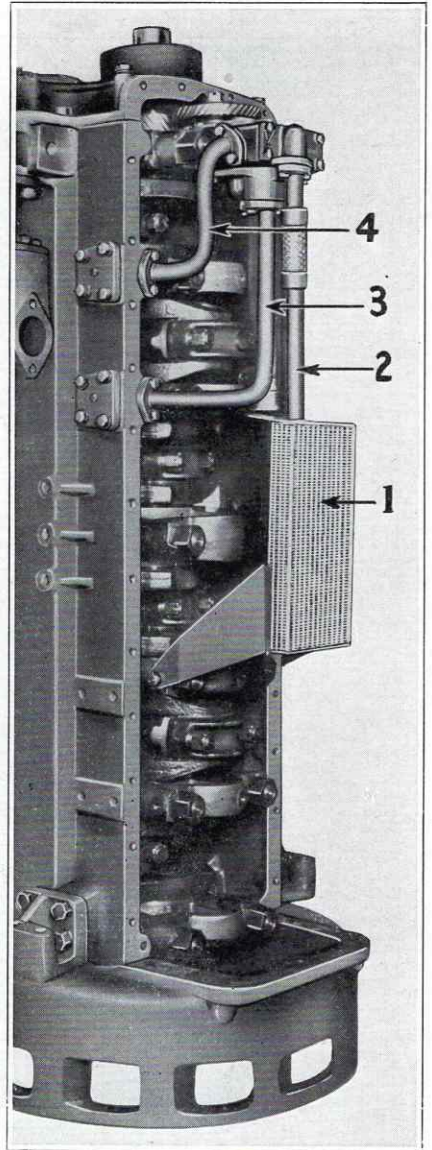

Illustration No. 36

Water Circulation and Water Pump:

Water is circulated by means of a centrifugal type pump shown in Illustrations Nos. 37 and 38. To remove this pump it is necessary to remove the generator, generator coupling, water pump discharge pipe, bypass tube and water inlet pipe, also disconnect the tachometer cable, if one is used. Figure 1, Illustration No. 37, shows

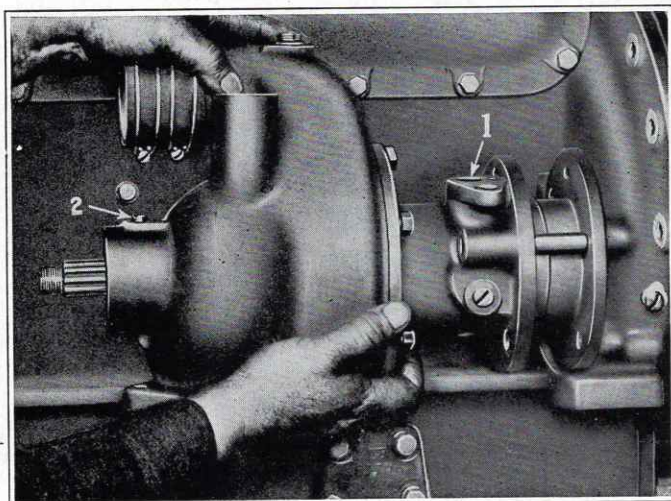

Illustration No. 37

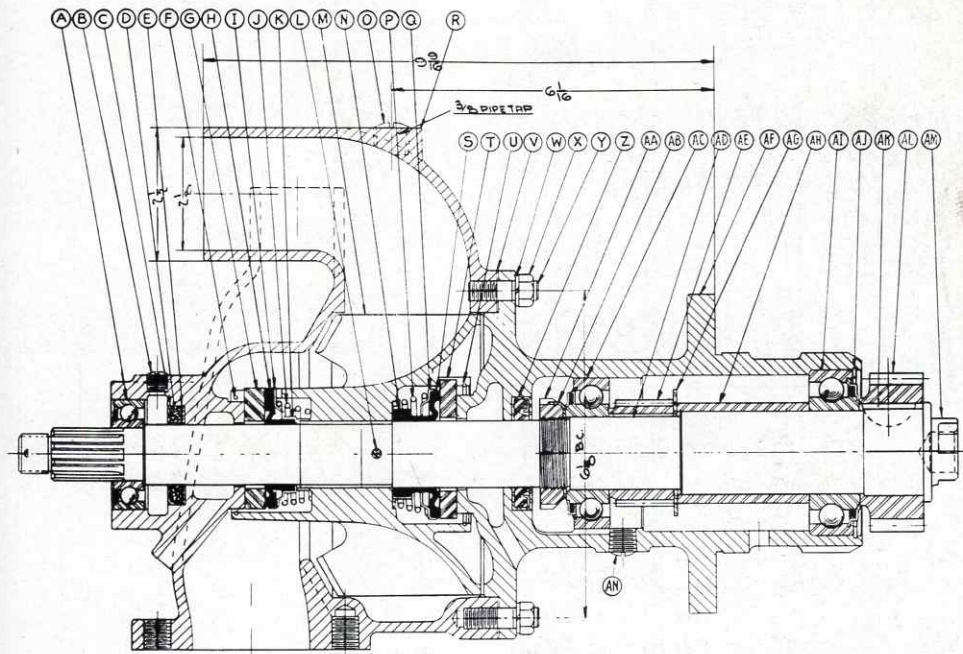

Illustration No. 38

location of tachometer drive if one is used. After the above parts are removed the pump attaching cap screws and stud nuts may be removed and the pump pulled directly toward the rear of the engine as shown in Illustration No. 37.

Illustration No. 38 shows the sectional view through the water pump and the relation of the component parts of this pump assembly. The pump can be separated into two larger parts by removing stud nuts X and washers W and pulling body R away from front half of water pump, uncovering the impeller (if gaskets are not available be careful not to damage gasket V). Rear water pump seal can then be removed by compressing snap ring F and pulling it out of the recess in the impeller. Note the relation of these parts as they are removed so that they can be reinstalled in their correct position. Inspect sealing washer G and if badly cut or broken, replace. It is also well to replace flexible seal H at this time.

To remove impeller it is necessary to first drive out pin L then remove snap ring AJ in the front of the pump right in back of the drive gear. The pump can then be supported on either flange AF or the flange right in back of W and after placing a piece of wood over the end of the shaft to protect the threads, the shaft can be pressed or driven out of the impeller and pump cradle. When the pump shaft presses off of the impeller, the shaft complete with the gear and the bearings will readily drop out of the cradle. To remove the bearings it is necessary to remove bearing nut AA and press these and the other parts, including the gear, off of the shaft.

The front seal can be removed from the impeller in the same manner as the rear seal by removing snap ring U. After parts have been inspected and renewed as required, reassembly is made in the reverse procedure.

To lubricate the pump, use the same grade of oil as is used in the engine or if available a grease equivalent to Standard Oil Co. Oneida Ball Bearing Grease, placing this in opening made by the removal of plug B, Illustration No. 38, or 2, Illustration No. 37.

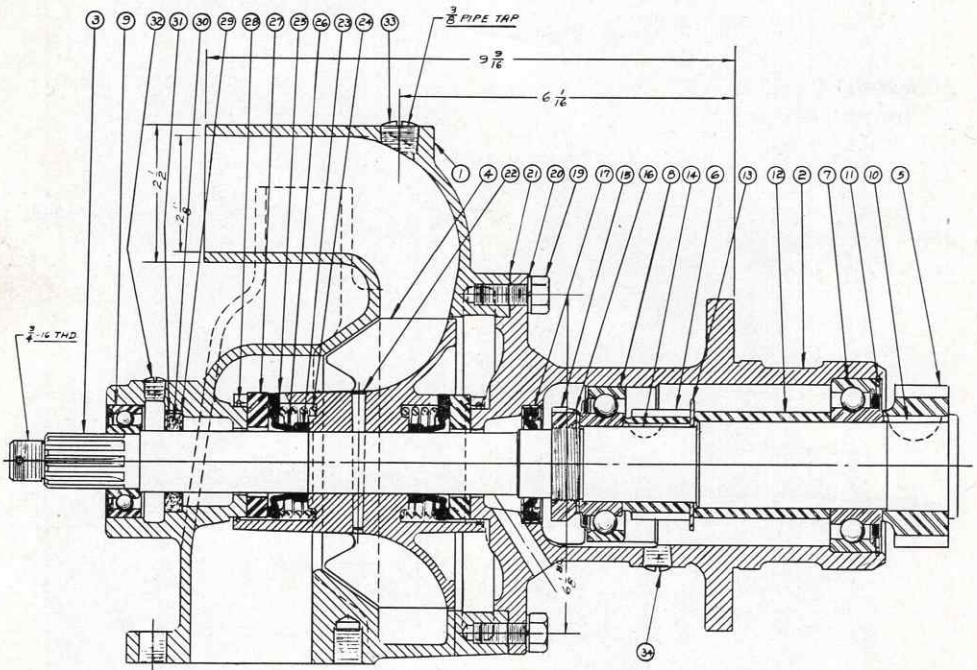

Illustration No. 39

Water Pump (Late Type): The latest type water pump shown in Illustration No. 39 differs primarily from the one shown in Illustration No. 38, in the method of fastening the impeller to the shaft, a tapered pin being used instead of serrations and a straight pin. This change has brought about changes not only in the impeller and shaft but also in the water pump body and seals. Both seals are the same in this setup and are constructed slightly different in that a cylindrical spring is now used instead

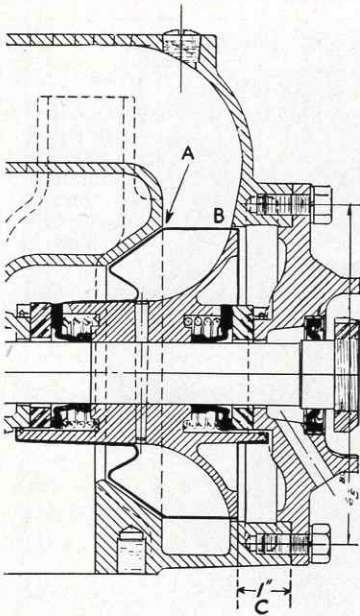

Illustration No. 39-A

NOTE: Due to very close working clearances between the impeller and housing at "A" and because the flow of water may be impeded at "B"; the impeller must be accurately located on the shaft so as to provide the necessary clearance at "A" and have the impeller line up with the housing at "B". Therefore, when pressing the impeller on the shaft, press it on until a dimension of 1" between the front cradle and the face of the impeller is obtained "C".

of a conical shaped spring. The pin hole in the shaft and impeller have been relocated. Other details are in general the same as for the first type pump.

The procedure for disassembling, repairing and reassembling this pump is the same as outlined for the previous type pump.

Fuel Pump Drive: The fuel pump is driven by means of a chain and sprockets, one sprocket being attached to the camshaft and the other to the fuel pump drive shaft. The general construction is shown in Illustration No. 40. A sleeve is attached to the cylinder block and can be removed toward the front of the engine after the gear cover has been removed, and the chain has been taken off the sprocket. Suitable oil seals are provided at the rear of this shaft to prevent oil leakage.

Fuel Pump Chain Adjustment: The chain is adjusted by means of an idler sprocket, which is mounted on an eccentric, which eccentric is supported by a stud 6, Illustration No. 40, which is fastened in the case by means of a flange and screws. The eccentric is controlled by a screw working in threads cut on the eccentric control split bushing which is keyed to the eccentric.

Perusal of Illustration No. 40 will show a projection 6 on the eccentric bushing which is longer and will come through the gear cover. Therefore, it is necessary whenever the gear cover is removed to be sure this extension is centered before tightening screws.

Illustration No. 41 shows the component parts of this adjustment. No. 1 is the threaded eccentric clamp bushing. No. 2 is the support for the adjusting screw which is shown as No. 3. No. 4 is the cork seal.

Illustration No. 42 shows the parts assembled on the engine and the method of adjustment is as follows:

1. Remove plug 1 which will allow you to feel chain movement. This should be approximately $\frac{3}{8}$ " up and down.

2. If movement is greater than $\frac{3}{8}$ " then remove cotter pin and loosen nut 3

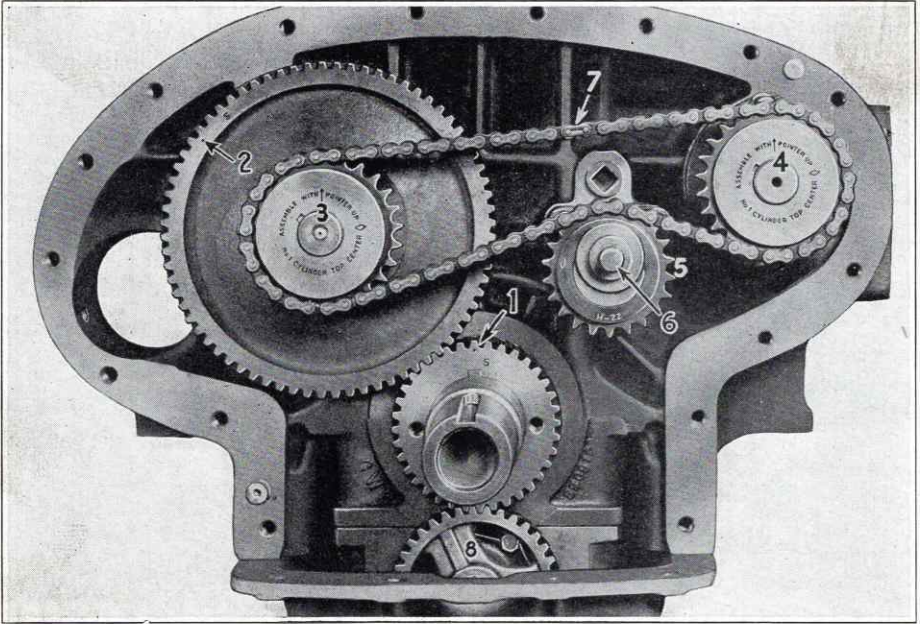

Illustration No. 40

3. With a screw driver turn screw 4 clockise, this causes eccentric threaded bushing 5 to turn clockwise thus tightening the chain.

4. Check tightness of chain at 2. This should be a movement of about $\frac{3}{8}$ ".

5. Should the chain be too taut turn screw driver anti-clockwise until nut 3 rests against support 2, Illustration No. 41, then turn driver until chain is loose. Reverse action and again tighten as outlined above.

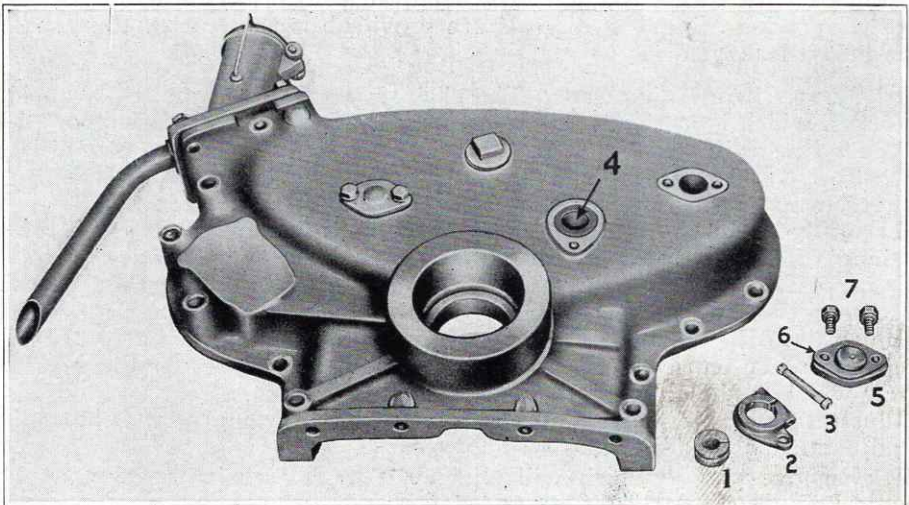

Illustration No. 41

6. Always turn screw clockwise before locking nut and putting in cotter pin as this insures all slack being removed which otherwise may cause the chain to be loose after engine is running.

It is never necessary to remove screw 6, Illustration No. 42, which holds adjustment support to gear cover except to replace seal 4, Illustration No. 41. By keeping these parts assembled to gear cover it facilitates re-installing gear cover after it has been removed. Remember to always try working adjustment before finally tightening the gear cover attaching screws.

Should it be impossible to remove plug 1, Illustration No. 42, then check chain adjustment by rotating fuel pump drive coupling back and forth. This movement or backflash should be about $\frac{1}{64}$ " on the O.D. of the coupling flange.

Fuel Pump Drive Chain Removal: The removal of the fuel pump chain is made by means of a small stamping which locks two of the chain rivets in place 7, Illustration No. 40. This stamping should be carefully spread so that it can be removed from the slots in the rivets; then the rivets can be pushed through the links of the chain, opening the chain and permitting its ready removal.

Replacement of Chain: Illustration No. 40. When the chain is to be replaced turn the engine so that the pointer 3 on the hub of the sprocket attached to the camshaft is vertical with No. 1 cylinder on top center, and rotate the sprocket attached to the fuel pump drive shaft, also into a vertical position as shown in 4. The chain should then be placed on the sprocket so as to permit these arrows to remain in a vertical position.

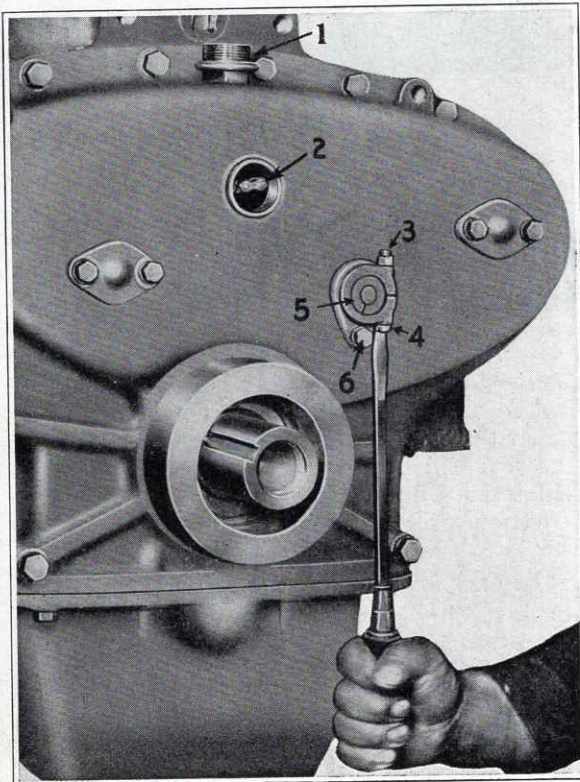

Illustration No. 42

Camshaft Drive: The camshaft is driven by means of a suitable gear which meshes with the crankshaft gear. The timing of these two gears requires no check of position of the valves. It is simply necessary to line up the punch marks on the two gears, the cam gear being shown as 2 and the crank gear as 1, Illustration No. 40.

Camshaft and Fuel Pump Drive End Play Adjustment: The end movement of these shafts is adjusted endwise by means of shims placed between the gear cover and

the thrust plates on castings shown as 5 and 6 in Illustration No. 41. The removal of shims will permit the plates to be re-assembled so as to take up any end play. Care must be exercised to prevent taking out too many shims, as this would throw a heavy thrust load on various thrust bearings. Also see 1, 2 and 3, Illustration No. 43.

One way of checking this condition is by putting a thin layer of Prussian Blue on the thrust surface, then bolt the plates into position, turn the engine over carefully one or two revolutions, remove the plate and observe the contact surface. If this shows a definite pressure the adjustment is too close, a clearance should be permitted for expansion of the various parts when they become hot. See clearance table on page 84 for recommendations.

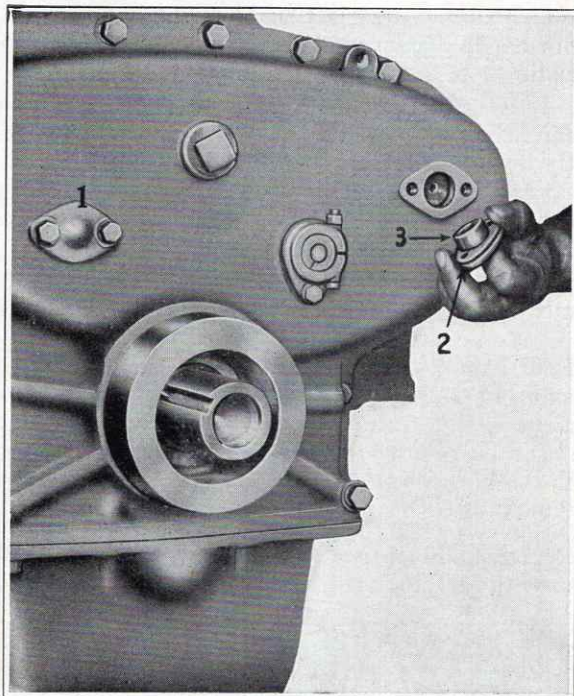

Illustration No. 43

Oil Seals: The construction of this engine prevents oil leakage when gaskets are in proper condition and all bolts and screws are properly tightened. Whenever a shaft extends through the engine case and there is a possibility of oil leakage an oil seal is used which also acts as a dust seal preventing dust entering the engine.

A patented composition seal is used in the water pump and fuel pump drive shaft to seal against leakage at these points. The crankshaft is sealed at the front end by a patented steel encased spring loaded leather or synthetic rubber type seal. It is necessary that the bore in the gear cover be concentric with the crankshaft, otherwise the seal will bear unevenly on the crankshaft and, besides wearing rapidly, will leak. The crankshaft must be free from nicks and other rough spots. To renew this seal, drive it out of gear cover and press in new seal.

When installing seals care must be exercised so that they are not mutilated.

Leakage is always corrected by installing new seals.

Bellhousing or Flywheel Housing: The flywheel housing covers the flywheel and to it the clutch or transmission housing is fastened. In many cases it serves as the rear motor support. Its installation is not difficult but care must be exercised to keep the bore for the seal as well as the clutch housing pilot bore concentric with the crankshaft; therefore, to install correctly, use of an indicator is imperative.

Flywheel Housing Seal:

Illustration No. 44 shows a section through the flywheel, flywheel housing, crankshaft and seal. This seal is of a patented type using leather or synthetic rubber as the sealing material and supported in a steel housing. Proper sealing depends on the flywheel pilot surface being polished so as to not cause seal to wear rapidly. Be sure all "nicks" or rough spots are off this part. If necessary polish with "Crocus" cloth.

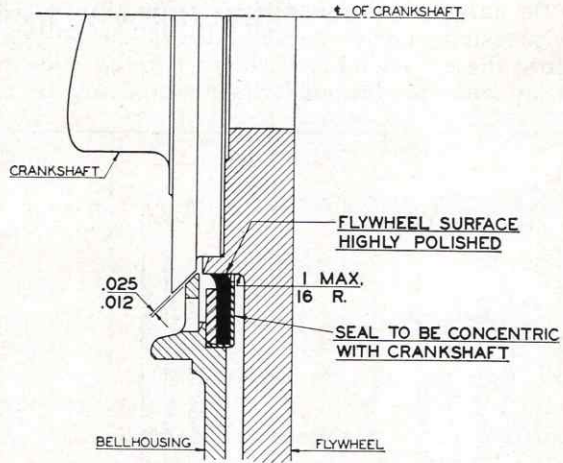

Illustration No. 44

The clearance between the housing chamfer and the crankshaft flange should be maintained between .012" and .025" to eliminate possibility of rear end oil leaks.

Oil Pan or Crankcase Cover: This part differs with various installations but should always have the same care. Keep all dirt out of it as it is the reservoir for the lubricating oil. It should be removed once every 2000 or 2500 hours (at least twice a year) and completely washed. While it is off the inside of the engine may be inspected and washed out. This procedure may require from 3 to 5 hours but it is well worth the time spent and pays good dividends in helping secure trouble-free operation. When re-installing use new gaskets for a leak-proof job.

The capacity of the standard type oil pan is 28 quarts U. S. measure. However, when refilling after draining, the best method to follow, since there are many special oil pans used, is the use of the bayonet gauge or dip stick. Fill crankcase to the 4/4 mark on this gauge, then run engine for about 4 or 5 minutes, stop, let set about 1/2 minute and measure oil level. If not up to 4/4 mark add enough oil to bring it to this level. If the oil has been measured, the next time the same amount may be used. Always recheck with bayonet gauge. With dry sump type, keep level in reservoir at proper height.

Gear Cover: The same instructions as given under the oil pan apply to the gaskets on this part, for seals refer to section on page 76.

Accessories: The manufacturers of these are always prepared to furnish additional information on their equipment to supplement the few remarks which we have been able to place in this book. Write to them direct or to the Hercules Motors Corporation and any available booklets on these parts will be sent you.

INSTRUCTIONS FOR REMOVAL AND INSTALLATION OF CYLINDER SLEEVES OR LINERS

Illustration No. 45 shows the position of the sleeve puller (designed and manufactured by the Hercules Motors Corporation) for removing and installing the dry type cylinder sleeves or liners, all necessary instructions are incorporated in this illustration.

Be sure to grease upper bearing through Zerk fitting before pulling out or pressing in each sleeve. Also oil sleeve before installing otherwise it may score the cylinder block sleeve bore or stick. After sleeve is installed, hone or lap so as to obtain clearances as shown in Table of Clearances on page 84.

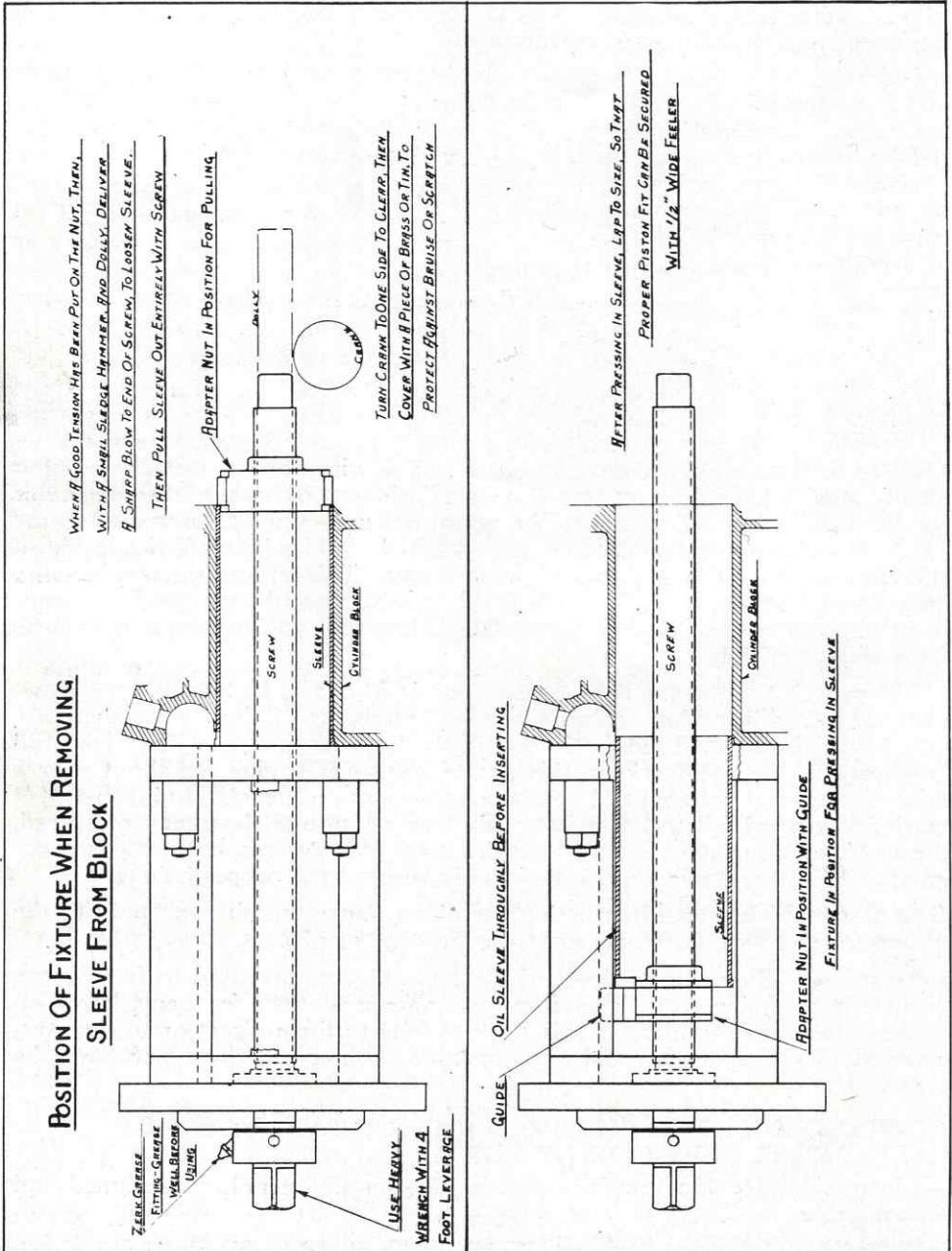

Illustration No. 45

INSPECTION OR ADJUSTMENTS

To Be Made Daily:

1. Go over the entire engine daily to make sure there are no loose bolts, nuts, screws, electrical connections, or parts, and also stop all fuel, lubricating oil and water leaks. There will probably be very little tightening needed but one loose part may cause serious damage.
2. Check lubricating oil level in both engine and injection pump bases and keep filled to the full mark on gauges.
3. Remove pipe plug in bottom of both fuel and lubricating oil filters and drain all water and sediment which may have accumulated.
4. Air cleaners should be inspected and cleaned before starting the day's run. If oil bath type are used renew the oil, filling to the proper level. If the engine is working in extremely dusty atmosphere it may be necessary to clean these units more often than once a day.
5. See that there is a day's supply of clean fuel in the tanks before starting.
6. Electrical equipment requires very little attention but the batteries should be checked daily for water which should be kept at a proper level.
7. The water circulating system probably receives less attention and care than any part of the engine installation and yet it is one of the most important units. Water should be added daily to make up for that lost in evaporation and leaks. Also observe if scale or sediment is forming in the cooling system and if it is obtain water from a supply which will not cause these troubles. If the water pump is leaking badly, replace the seals with new ones.
8. If air temperature is freezing or liable to get down to freezing, check anti-freeze solution, making sure it will not freeze at temperatures well below those being experienced.

Inspection or Adjustments To Be Made After Each 100 Hours Operation:

1. Check fuel pump driving chain and tighten if necessary.
2. Inspect and adjust fan belts if loose.
3. Inspect radiator and clean if clogged or shows scale formation.
4. Drain the fuel supply tank and wash out thoroughly with clean fuel oil to remove all dirt and sediment. Remove air from fuel filters, by opening vent cocks.
5. Tighten cylinder head nuts and inspect valve clearance.
6. Examine timing marks on fuel injection pump coupling to see that the timing is correct and the coupling has not slipped or been tampered with.

Lubrication of Electrical Equipment at Each 500 Hours of Operation:

1. Lubricate generator. Three to four drops of the same grade and quality lubricating oil as is used in the engine crankcase is all that is necessary. Too much lubrication is as bad as too little, as too much will flood the generator with oil and get on the commutator and brushes, causing the brushes to stick in the holders.
2. Lubricate the starting motor, if equipped with oilers, with the same grade of oil as is used in lubricating the generator. These motors have absorbing bushings so fill cups with oil until the bearings are saturated. Motors not equipped with oilers have oilless bushings and need no lubrication except at time of overhaul.

“TROUBLE SHOOTING”

ENGINE WON'T START OR HARD STARTING

- (a) No fuel in tank—Fill Tank.
- (b) No fuel in fuel pump—See Starting, page 7.
- (c) Not properly prepared for starting at the atmospheric temperature being encountered—See Starting, pages 7, 8, 9, 10, and 11.
- (d) Weak batteries will not turn engine over rapidly enough—Recharge batteries.
- (e) Fuel too heavy to flow through pipes properly—Lighter fuel. See Fuel Oil Specifications, page 20.
- (f) Water in fuel—Drain fuel system and tanks. Change fuel supply.
- (g) Rings or cylinder walls worn badly—Replace with new.
- (h) Exhaust or intake valve seat pitted or worn—Regrind valves.
- (i) Leaking head gasket—Replace gasket.
- (j) Air cleaner plugged, not allowing sufficient air to pass through—Clean air cleaner.
- (k) Governor stop lever stuck in shut-off or stop position.

ENGINE STOPS SUDDENLY

- 1. No fuel—Fill tank, prime and start as under Starting, pages 7, 8 and 9.
- 2. Fuel pumps or lines air or gas bound—See Starting, page 8.
- 3. Fuel filter plugged—Clean filter then prime lines.
- 4. Obstruction in or broken fuel line—Check, starting with fuel tank to strainer.
- 5. Water in fuel—Drain entire system including tank and clean. Fill with clean fuel and then proceed as under Starting, pages 7, 8 and 9.
- 6. Transfer pump not functioning properly—Inspect valves, springs, gaskets, plunger, roller and guide.
- 7. Piston seizure due to lack of lubrication—Remove piston and replace with new if badly scored. Change lubricating oil after thoroughly cleaning oil pan, lines and filter.
- 8. Bearing seizure due to lack of lubrication—If not too badly wiped, scrape enough to clean up and reinstall. If badly wiped, replace with new.
- 9. Broken fuel pump driving chain—Replace with new chain and re-time engine. See Timing Fuel Pump, page 24.
- 10. Fuel pump adjustable coupling slipped due to not being properly tightened—Retime pump. See page 24.

ENGINE MISSING ERRATICALLY OR INTERMITTENTLY

On All Cylinders

- 1. Improper fuel, fuel with poor burning qualities—Drain system including tank and refill with suitable fuel.
- 2. Water in fuel—Drain fuel system including tank of all water and sediment. Refill with clean fuel.
- 3. Sticking nozzle valve stems or pump delivery valves or both—Remove stuck parts and clean. Caused usually from dirty fuel. Clean entire system after draining and fill with clean fuel.

TROUBLE SHOOTING

4. Worn piston rings or cylinders or both—Replace with new.
5. Leaky intake or exhaust valves or both—Regrind valves.
6. Plugged air cleaner reducing air admitted into cylinders—Clean air cleaner.

ENGINE MISSING

On 1 or 2 Cylinders

To determine which cylinder or cylinders are missing, loosen the nuts connecting the fuel lines to the fuel nozzles one at a time. If the engine speed remains the same and exhaust sounds the same that is the cylinder missing. If the engine speed slows down and the exhaust loses its same rhythm then the cylinder is functioning.

1. Fuel valve stuck in body—Remove and clean.
2. Air or gas binding in fuel pump or lines—Usually when testing to see what cylinder is missing this condition will be cleared up as opening the nut allows the air or gas to escape.
3. Exhaust or intake valve stuck—Remove valve cover and check which one stuck. Free with kerosene, gasoline or alcohol poured down stem. Alcohol is the quickest solvent. If still sticks, remove head and determine cause.
4. Leaky exhaust or intake valve—Regrind valve.
5. Exhaust or intake valve spring or spring retainer lock broken—Replace with new.
6. Improper exhaust or intake valve clearance between valve and rocker arm—Check clearance and reset to proper clearance.
7. Fuel pump delivery valve leaking or stuck—Remove and clean with soft cloth and clean fuel oil or gasoline. If cleaning does not free the valve remove both valve and seat and install new. (These valves and seats must be used as an assembly as parts are not interchangeable one seat with another valve.)
8. Fuel pump delivery valve spring broken—Replace with new.
9. Piston rings or cylinder walls badly worn—Replace with new.

CAUSES AND REMEDIES

Smoke in Exhaust

The brown or black color in exhaust is pure carbon—one of the elements of the fuel, the other being hydrogen. When combined they form liquid oil or gas which may be perfectly transparent or clear in the case of oil and absolutely invisible in the form of gas. These minute particles of carbon are solid substances and black. Their presence in the exhaust gas makes it appear as dark or black smoke. The more carbon particles, the darker color the exhaust, ranging from a very light gray haze to brown and even black smoke. The cause is incomplete combustion. Since combustion is never perfectly complete, it is not presumed that exhaust gases will be absolutely invisible. Smoke from the exhaust, either brown or black, is not itself mechanically harmful to the engine but may indicate corrections that should be made particularly if an increase of smoke appears with no change in conditions such as load, speeds, temperatures, change of fuel oil, or engine taken to higher altitude.

Increase of Brown or Black Smoke in Exhaust Gases

- Cause 1. Leaky cylinder head gasket.
Remedy Remove and clean or replace from spares.
- Cause 2. Leaky valves.
Remedy Regrind.
- Cause 3. Improper fuel oil.
Remedy Change fuel to brand with good ignition and burning qualities.
- Cause 4. Dirty spray nozzles.
Remedy Clean.
- Cause 5. Fuel injection timing too early usually accompanied with "Fuel knocks" or "noisy engine."
Remedy Adjust timing of injection.
- Cause 6. Fuel injection timing too late accompanied with loss of power but smooth and quiet running engine.
Remedy Adjust timing of injection.
- Cause 7. Leaky piston rings.
Remedy Replace with new ones from spares.
- Cause 8. Fuel delivery valve in fuel pump stuck.
Remedy Remove and clean with soft cloth. Do not use hard or sharp tools or abrasives. They will spoil these parts. If valve cannot be made to operate freely have replacement of new valve and seat assembly made at a Bosch Diesel Service Station.
- Cause 9. Fuel delivery valve spring in fuel pump broken.
Remedy Replace with new one from spares.
- Cause 10. Fuel pump drive chain too loose.
Remedy Tighten and retune engine.

Knocking in Engine or "Fuel Knocks"

Fuel knocks may come from one or more cylinders. If knocking is from one cylinder:

- Cause 1. Spray nozzle valve sticking from dirt or corrosion.
Remedy Clean valve with a cloth (not abrasives) and clean body with piece of wood. Turn valve stem in body until free, then smear with good clean engine lubricating oil or vaseline and replace.
- Cause 2. Spray nozzle spring broken.
Remedy Replace complete holder from spares. Never attempt to change nozzle springs in field as they must be accurately calibrated with instruments, at the factory.
- Cause 3. Fuel delivery valve in pump stuck open from dirt or corrosion.
Remedy Clean valve stem with cloth and valve seat with small piece of wood. Do not use abrasives or metallic tools, they will spoil these delicate parts.
If necessary, replace with new valve and seat at Bosch Diesel Service Station.
- Cause 4. Broken delivery valve spring in fuel pump.
Remedy Replace from spares.
- Cause 5. Inlet or exhaust valve not seating properly from sticking or in need of grinding.

TROUBLE SHOOTING

- Remedy Free valve with alcohol or other solvent, such as kerosene or clean fuel oil or gasoline. Grind valve if necessary.
- Cause 6. Leaky cylinder head gasket.
- Remedy Clean or replace from spares.

If "Fuel Knocking" is in more than one cylinder and erratic and intermittent:

- Cause 1. Improper fuel. Has poor ignition qualities.
- Remedy Add equal parts or more if needed of fuel oil with good ignition qualities or change fuel to a brand having good ignition and burning qualities. See specifications of fuel oil.
- Cause 2. Sticking nozzle valve. This comes from dirt in fuel oil or corrosion of these parts from acid in the fuel oil.
- Remedy Dismantle and clean the parts and also fuel strainers. If parts are corroded, change fuel to an acid free brand and install new nozzle and pintle if necessary.
- Cause 3. Water in fuel oil.
- Remedy Drain fuel oil strainer sump and fuel tank of all water and sediment.

If "Fuel Knocking" is in all cylinders continuous and steady and is usually accompanied with dark smoky exhaust:

- Cause 1. Improper fuel oil, has poor ignition qualities.
- Remedy Change fuel to brand of suitable ignition qualities or add equal quantities or more if needed of fuel oil with good ignition qualities.

Knocking from Mechanical Causes may be from several sources among which are:

- Cause 1. Piston hitting inlet and exhaust valves from using improper gasket.
- Remedy Use only those supplied by Hercules Motors Corporation.
- Cause 2. Pistons hitting exhaust and inlet valves from bearings badly worn.
- Remedy Replace with new bearing shells.
- Cause 3. Valve tappet clearance too great.
- Remedy Adjust clearances.
- Cause 4. Badly worn bearings, either main or rod or both.
- Remedy Adjust or replace with new bearing shells.
- Cause 5. Badly worn piston pins or bushings, or both.
- Remedy Replace with new.
- Cause 6. Badly worn pistons or liners or both.
- Remedy Replace with new.
- Cause 7. Loose flywheel.
- Remedy Tighten.

There are many other mechanical causes of knocks which must be found and remedied but it is impossible to list all of them in a book such as this. If impossible to determine what the trouble is after a thorough investigation it is best to have a factory trained expert investigate and remedy the trouble.

Clearances "DFX" Series

Bearing Clearances	Minimum	Maximum
Camshaft Bearing Clearance003	.0035
Connecting Rod Clearance in Bearing0035	.0045
Crankshaft Bearing Clearance005	.006
Fuel Pump Drive Shaft0025	.003
Idler Bearing Clearance001	.002
Oil Pump Shaft Bearing Clearance0015	.002
Rocker Arm Bushing Clearance001	.0015
Piston Pin Clearance in Rod Bushing0015	.002
End Thrust		
Camshaft End Thrust005	.008
Connecting Rod Side Clearance005	.012
Crankshaft Thrust Clearance004	.005
Fuel Pump Drive Shaft End Thrust005	.008
Oil Pump Shaft End Thrust002	.003
Back Lash		
Crankshaft Gear Back Lash to Camshaft Gear001	.002
Oil Pump Gear Back Lash006	.010
Timing Chain—Measured on O.D. of Coupling	$\frac{1}{64}$	
Water Pump Gear Back Lash002	.004
Piston		
Piston Clearance—DFXB008	.0085
Piston Clearance—DFXC—DFXD—DFXE0085	.0095
Piston Clearance—DFXH014	.015
Piston Clearance to Cylinder Head085	.125
Piston Pin Clearance in Piston (Push Fit—Piston Hot)0000	.0005
Piston Ring Gap—Oil and Comp.018	.022
Piston Ring Land Clearance0015	.003
Valves		
Valve Guide Clearance Around Stems—		
Exhaust and Intake0025	.003
Valve Head Below Cylinder Head—Intake030	.035
Valve Head Below Cylinder Head—Exhaust050	.055
Valve Seat—Exhaust $1\frac{15}{16}$ "		
Valve Seat—Intake $2\frac{21}{32}$ "		
Face of Seat—Exhaust and Intake $1\frac{3}{4}$ " Wide		
Valve Tappet Clearance in Bracket001	.0015
Rocker Arm to Valve Stem Clearance—		
Exhaust (Hot)016	
Rocker Arm to Valve Stem Clearance—		
Intake (Hot)010	
Miscellaneous		
Bellhousing Clearance on Chamfer014	.025
Cylinder Liner Above Block000	.001
Gear Cover Clearance Around Crankshaft006	.015

(All Above Clearances Given In Inches)

WRENCH TENSION

WRENCH TENSION (For Tightening Nuts)

	Foot Pounds
Cylinder Head Stud Nut	300
Connecting Rod Nut	263
Main Bearing	260

All other screws, nuts, etc., are to be drawn up snug and tight but not to the point of stripping the threads.

LUBRICATION *is your biggest asset
to offset your greatest liability . . .*
UNNECESSARY REPAIRS . . . Use
only the BEST OIL obtainable.

HORIZONTAL TYPE DFX SERIES ENGINES

13. Viscometer Gauge—This shows the viscosity of the oil (see section starting on page 15).

14. Oil Temperature Gauge.

15. Engine Cut Out Switch.

16. Engine Test Switch.

17. Local Engine Starting Switch.

18. High Water Temperature, Low Oil Pressure Safety Switch Restart Button—It is necessary to reset this switch after the engine has been shut down from either too high an oil temperature or too low an oil pressure. This is done by turning the switch to the correct location for starting.

ILLUSTRATION No. 47, TOP AND LEFT HAND SIDE:

1. Breather Caps.
2. Oil Compartment Drain.
3. Oil Temperature Unit—Remove to drain this compartment.
4. Cover Plate.
5. Cover Plate over Oil Line Connections.
6. Main Oil Pressure Line from Oil Filter to Cylinder Block.
7. Oil Filler Pipe Cap.
8. Oil Filler Pipe.
9. Oil Pressure Regulator.
10. Oil Filter.
11. Fuel Injection Pump.

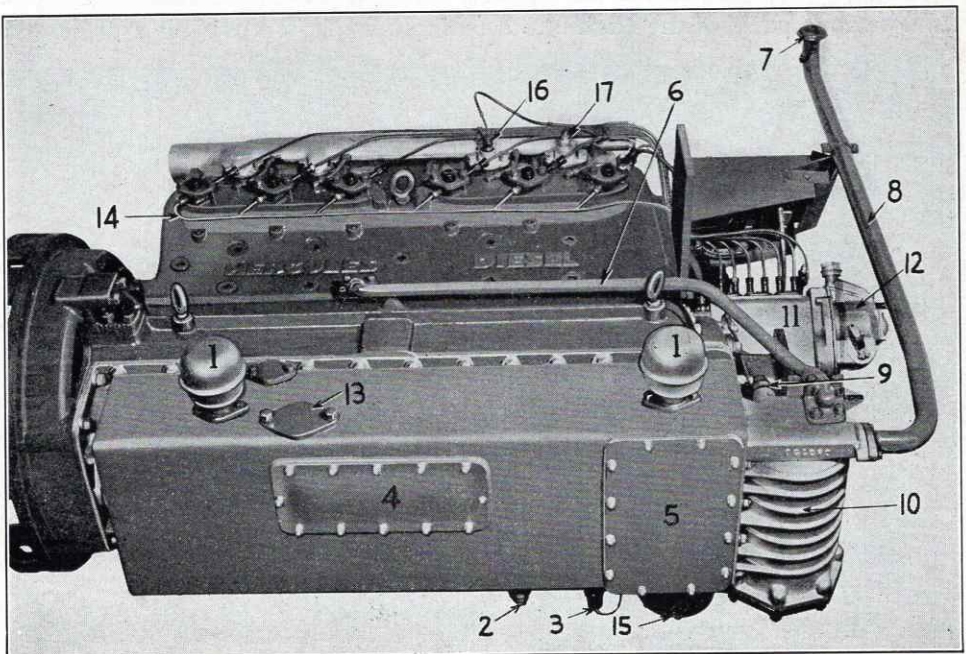

Illustration No. 47

12. Fuel Injection Pump Governor.
13. Oil Level Gauge Provision.
14. Fuel Nozzle Leak-off Manifold.
15. Oil Pan Oil Strainer.
16. High Water Temperature Cut-out Connection.
17. Water Thermometer Connection.

ILLUSTRATION No. 48, FRONT VIEW:

1. Breather Caps.
2. Oil Filler Pipe.
3. Oil Filter.
4. Gear Compartment to Oil Pan Connecting Pipe.
5. Oil Pressure Pipe from Filter to Crankcase.
6. Viscometer Instrument (see section starting on page 14).
7. Oil Pressure Regulator.
8. Fuel Pump Governor.
9. Fuel Oil Strainer (Filter).
10. Tachometer Cable.
11. Fuel Injection Pump to Nozzle High Pressure Lines.
12. Fuel Pump Governor Control Lever.

OIL PAN AND OILING SYSTEM:

One of the main differences between this engine and the vertical type is in the oiling system, the oil pan serving as a reservoir for the oil which is pumped from various parts of the engine to a main sump thus providing a dry sump

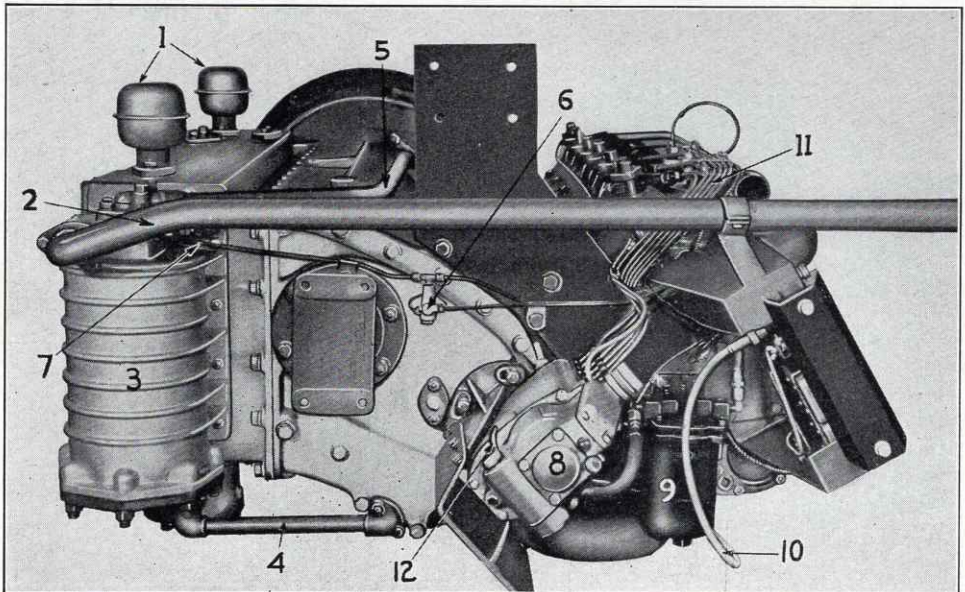

Illustration No. 48

engine. The oil pump and the various oil lines are shown in Illustrations 49 and 50, 1 being the oil pump, 2 the scavenging oil line from the rear of the engine to the oil pump, 3 the scavenging oil line from the front engine compartment to the oil pump, 4 the scavenging discharge line from the oil pump to the oil reservoir in the oil pan, 5 oil pump suction line from oil reservoir to oil pump, 6 oil pressure line from oil pump to oil filter and oil line 6, Illustration 47, is the oil pressure line from the oil filter to the cylinder block and crankcase. Oil line 4, illustration 48, is the interconnecting line between the gear compartment and the front scavenging compartment of the oil pan.

Before removal of the oil pan can be completed it is necessary that oil filter 10, Illustration 47, and covers 4 and 5 be removed in order to have access to these oil lines which are connected not only to the oil pump but also to the oil pan.

Should the oil pan and oil lines ever be removed be sure when reinstalling to use new gaskets and have the flanges bolted up tight to the oil pan and pump so that no oil will escape. This is particularly true on the pressure lines although scavenging lines will not remove the oil from the various compartments if they should have any leaks in them.

GEAR TRAIN:

The gears in this engine are located in slightly different positions than in the vertical job and these are shown in Illustration 49 as follows: 7 oil pump drive gear, 8 crankshaft gear, 9 camshaft gear, 10 fuel injection pump drive gear. The camshaft is timed to the crankshaft gear in the same manner as the vertical engines by placing the two punch marks on the gear teeth together as indicated at 12. A chain is not used on the horizontal type engine for driving the fuel pump.

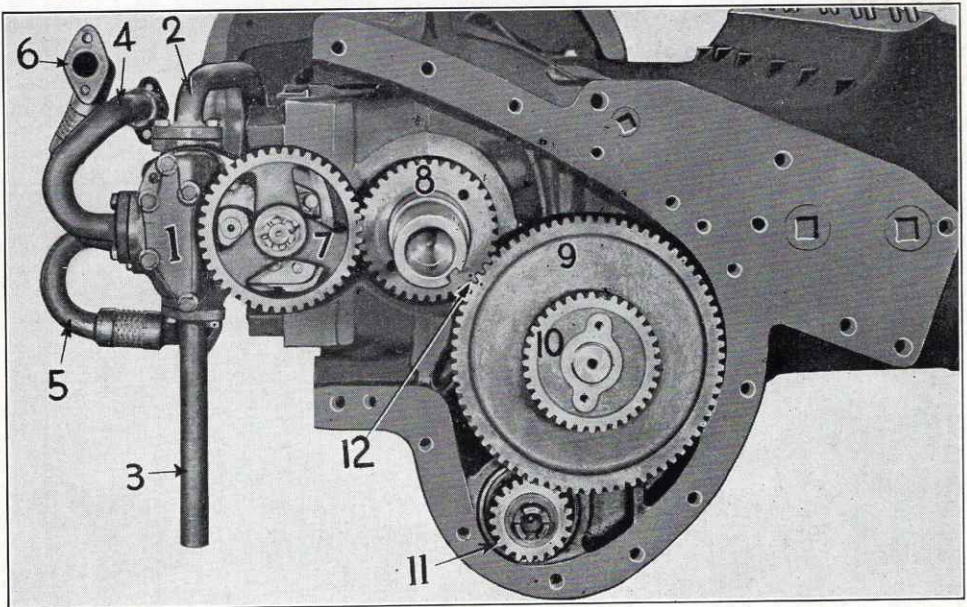

Illustration No. 49

FUEL INJECTION PUMP AND TIMING:

(Read section starting on page 24)

Since the fuel injection pump on the horizontal type engine is mounted on the front of the gear cover, it is driven by a gear mounted on the fuel injection pump camshaft. This, therefore, changes the procedure for timing the fuel injection pump as outlined under the vertical engine.

After spotting the engine on the 29° timing position of the flywheel as described on page 24, it is then necessary to rotate the gear on the fuel injection pump until the line on the gear tooth is in line with the mark on the fuel pump housing directly in back of and above the gear. With the fuel pump thus set engage the gear with gear 10, Illustration 49, which is mounted on the engine camshaft, then fasten the fuel injection pump bracket to the gear cover, tightening the stud nuts just finger tight so that the pump and bracket can be rotated.

With the stud nuts loose outside the slotted holes of the bracket, proceed to check engine timing by the flowing method, turning the fuel pump bracket clockwise as far as the slots will allow, then rotate counter-clockwise until the fuel just stops flowing from No. 1 delivery valve holder hole. This then places the engine in time at the predetermined point spotted on the flywheel. When in time, tighten stud nuts, making sure pump has not moved and started fuel to flowing.

Should it be impossible to rotate the fuel pump far enough to allow the fuel to quit flowing, it is then necessary to remove the fuel pump and bracket and locate it in another gear tooth so that it will be possible to have the fuel stop flowing while timing the injection pump. The procedure is the same as given on page 24, 25 and 26 except instead of turning the fuel pump coupling flange it is necessary to rotate the entire fuel pump and bracket.

MISCELLANEOUS:

Other parts such as bearings, pistons, cylinder heads, valves, et cetera, are maintained the same as in the vertical type engine described in this book. Clearances listed on page 84 and wrench tensions are listed on page 85, apply to this engine as well as the vertical type.

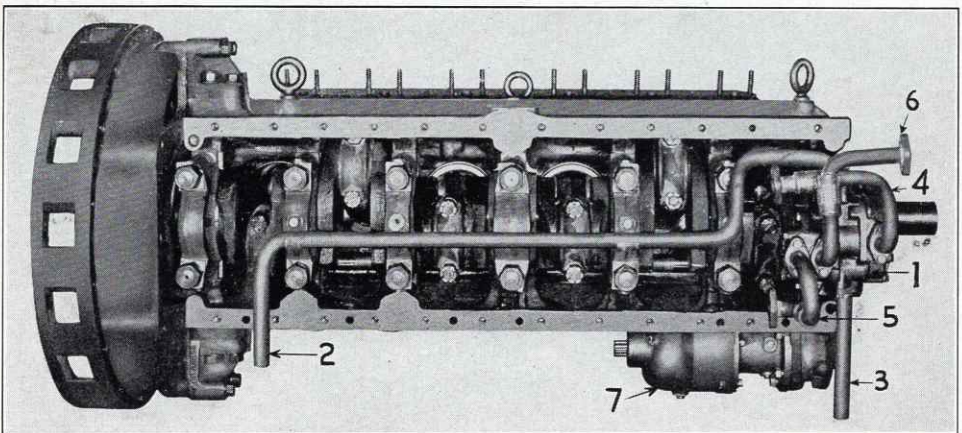

Illustration No. 50

HERCULES MOTORS CORPORATION

CANTON, OHIO

Hercules Motors Corporation is a Member of the Internal Combustion Engine Institute and is pleased to warrant all Hercules products sold by it in accordance with the following Basic Warranty adopted by the Institute May 8, 1947, which is subject to future amendment without notice. This warranty is in lieu of any warranty expressed or implied by law and supersedes any different warranty in customer's purchase orders.

BASIC WARRANTY

The Manufacturer warrants each new engine sold by the Manufacturer to be free from defects in material and workmanship for six (6) months from date of shipment, but not to exceed ninety (90) days of service, or such other period of time as may be agreed upon in respect to the application in which the engine is used. The obligation under this Warranty, statutory or otherwise, is limited to the replacement or repair at the Manufacturer's factory or at a point designated by the Manufacturer, of such part as shall appear to the Manufacturer, upon inspection at such point, to have been defective in material or workmanship.

This Warranty does not obligate the Manufacturer to bear the cost of labor or transportation charges in connection with the replacement or repair of defective parts, nor shall it apply to an engine upon which repairs or alterations have been made unless authorized by the Manufacturer.

The Manufacturer makes no Warranty in respect to trade accessories, such being subject to the Warranties of their respective Manufacturers.

The Manufacturer shall in no event be liable for consequential damages or contingent liabilities arising out of the failure of any engine or parts to operate properly.

No express, implied or statutory Warranty other than herein set forth is made or authorized by the Manufacturer.

New service parts are sold subject to the same warranty as new engines.

General Index



	Text Page		Text Page
A			
Accessories	77	Gear Cover	77
Air Filters or Cleaners	57-58	Gear Train	89
Air Intake Heater	10-11	General Description and Maintenance	60
Altitude Operation	14-15	Governors—Bosch GVA	30
B			
Batteries	7	Governors—Hercules	45
Bellhousing or Flywheel Housing	76	H	
C			
Camshaft and Fuel Pump Drive		Hard Starting	80
Endplay Adjustment	75-76	Horizontal Type Engine	86-87-88-89-90
Camshaft Drive	75	I	
Care of Fuel Nozzles	27	Installation and Removal of	
Care of Viscometer	19	Cylinder Sleeves	77-78
Causes and Remedies	81-82-83	Inspection or Adjustments	79
Caution	62	Introduction	3
Check Valve	22	L	
Cleaning and Testing Spray		Lubricating Oil	15-16
Nozzles	27-28	Lubricating Oil and Visco Meter	15-16
Clearance Table	84	Lubricating Oil Filter	59-60-68
Combustion Chamber	63	Lubricating System	66
Cold Weather Starting	9-10-11	M	
Connecting Rod	62	Main Bearing Adjustment	61
Connecting Rod Bearing	62	Main Bearings	61
Crankcase and Cylinder Block	60-61	N	
Cylinder Head	64	Nomenclature of Parts	47
Cylinder Head Gasket	64	O	
Cylinder Sleeve Removal and		Oil Pan or Crankcase Cover	77-88-89
Installation	77-78	Oil Pressure Adjustment	68-69-70
D			
Dry Sump System	67-68	Oil Pump	66
E			
Engine Missing Erratically	80-81	Oil Seals	76
Engine Missing on 1 or 2 Cylinders	81	Operating Instructions After	
Engine Stops Suddenly	80	Starting	11-12
Engine Won't Start or Hard Starting	80	P	
F			
Filters	57	Piston	62-63
First Time Engine Started	7-8	Piston Clearance	63
Flywheel Housing	76	Piston Pin	62
Flywheel Housing Seal	77	Precautions	5-6-7
Fuel Injection Equipment	20-21-22-23	Prelude to Operation	5
Fuel Injection Pump	23	Preparing Engine	13-14
Fuel Nozzle and Holder Assembly	26	Preparing Engine for Starting	14
Fuel Nozzle Pressure	29	Preparing Fuel Injection System	12-13
Fuel Oil	20	Priming Fuel System	8-9
Fuel Oil Filters	58-59	R	
Fuel Pump Drive	73	Replacement of Chain	75
Fuel Pump Drive Chain		Ring Gap and Groove Clearance	63
Adjustment	73-74-75		
Fuel Pump Drive Chain Removal	75		
Fuel Pump Governor	30 and 45		
Fuel Pump Timing	23-24-25-90		
Fuel Pump Timing When			
Couplings Are Marked	25-26		
Fuel Transfer Pump	22-23		

GENERAL INDEX (Continued)

	Text Page
S	
Save Your Batteries	7
Selecting Oil by Means of Visco Meter	17-18-19
Specifications	4
Starting and Operating Suggestions	7
Starting Between 50° F and 32° F.	9-10
Starting Between 32° F. and 0° F.	10
Starting 0° and Below	10
Starting the Engine	7-8-9
Stopping the Engine	12
Storing Engine for Long Periods	12-13-14

T	
Timing Fuel Injection Pump by Flowing Method	23-24-25
Timing New Fuel Injection Pump	26
To Clean Fuel Filters	58-59
"Trouble Shooting"	80-81-82-83

	Text Page
U	
Usual Routine Way of Starting Engine	9

V	
Valve Grinding	64-65
Valve Mechanism	64
Valve Tappet Assembly	65-66
Visco Meter	16-17-68

W	
Warranty	91
Water Circulation	71-72-73
Water Pump	71-72-73
Wet Sump System	66-67
Wrench Tension	85

GROUP INDEX

Altitude Operation	14-15
Clearance Table	84
Cold Weather Starting	9-10
Filters	57-58-59-60
Fuel Injection Equipment	20 to 26
Fuel Nozzle and Holder Assembly	26-27-28-29
Fuel Oil	20
General Description and Maintenance	60 to 78
Governors	30 to 57
Horizontal Type Engine	86 to 90
Inspection and Adjustments	79
Lubricating Oil and Visco Meter	15 to 19

Nomenclature of Parts	47
Operating Instructions After Starting	11-12
Precautions	5-6-7
Prelude to Operation	5
Specifications	4
Starting and Operating Suggestions	7
Starting the Engine	7-8-9
Stopping the Engine	12
Storing Engine for Long Periods	12-13-14
"Trouble Shooting"	80 to 83
Wrench Tension	85

Dryset. 140 kg pt. □ cm.

Uds. 0.016 " 0.4 mm.

End. 0.010 " 0.25 mm.

Tap. 350

Plsd. 263 | 3 5/16 " 84,138 mm. |

Novl. 260. | 4 1/2 " 114,300 mm. |

29° For Tap.



