

VTR 160 & VTR 200 Pa Pb ; Rc

Lager Gebläsesseite
 Palier côté soufflante
 Blower side bearing
 Cojinete lado soplante
 Cuscinetto lato soffiante
 Chumaceira do lado do compressor
 Compressorzijdig lager

Lager Turbinenseite
 Palier côté turbine
 Turbine side bearing
 Cojinete lado turbina
 Cuscinetto lato turbina
 Chumaceira do lado da turbina
 Turbinezijdig lager

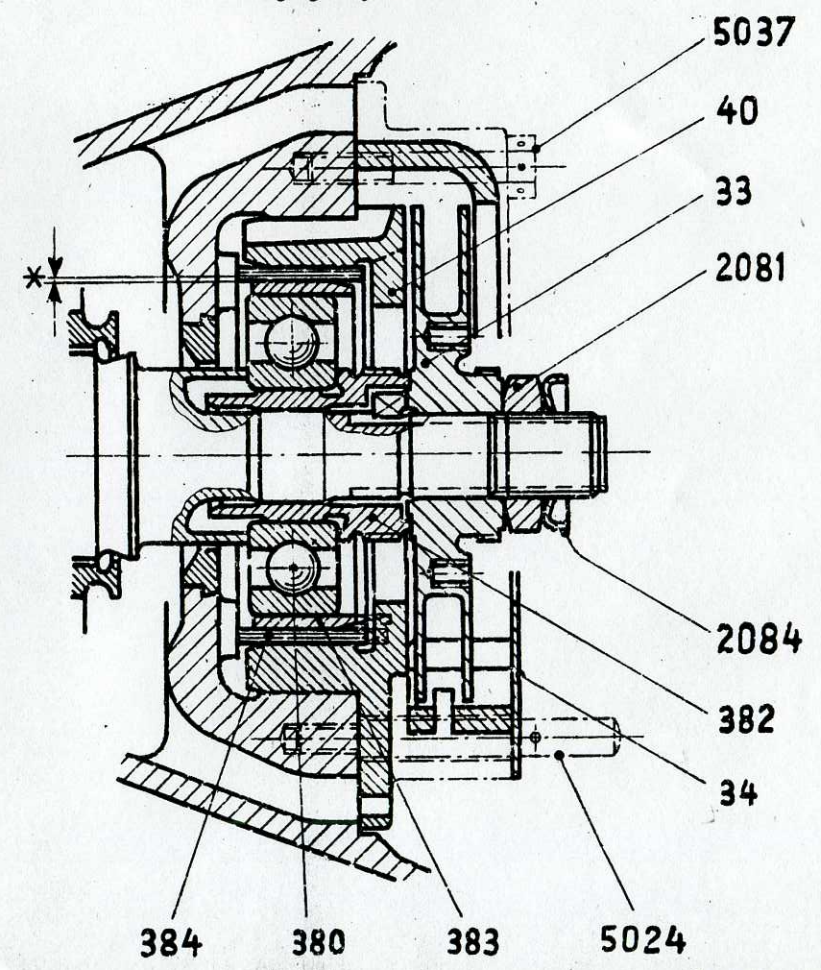
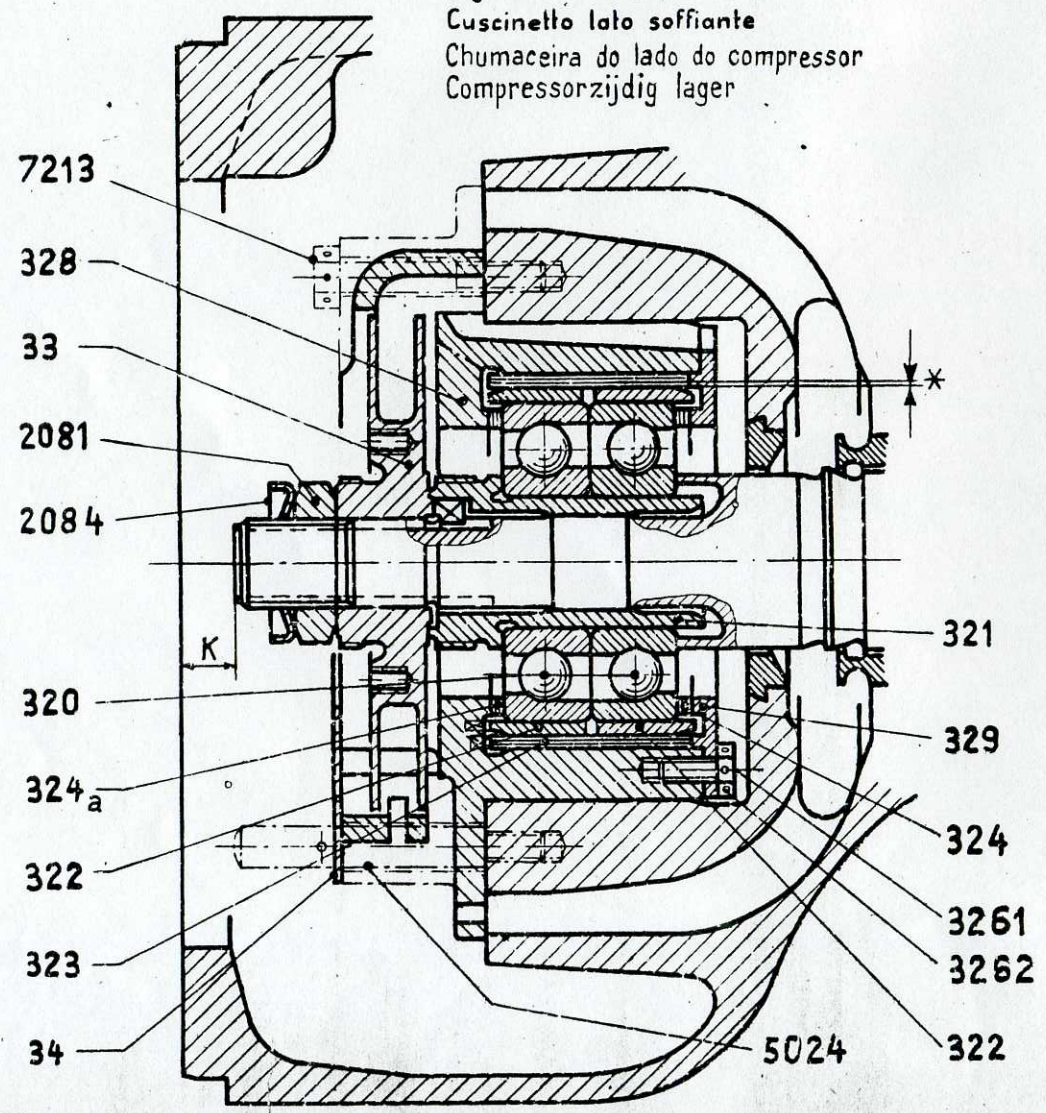

B

VTR 160-320 *Kontrollering af det indbyggede Bløserleje.*

(A)
rigtig.

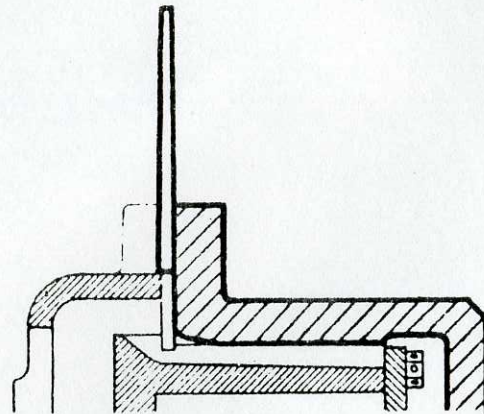
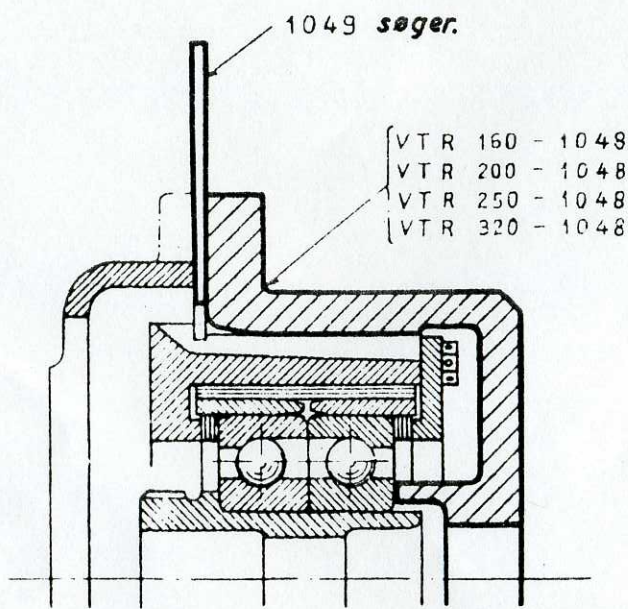

(B)

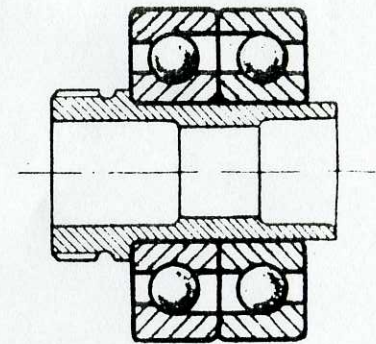

(C)

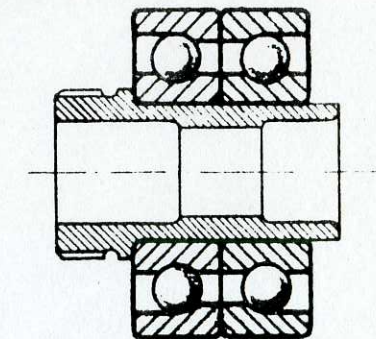

(A₁)
forkert.

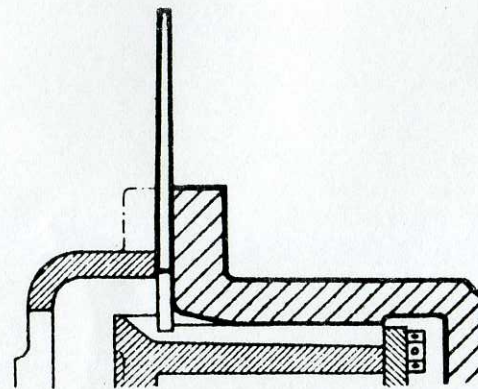
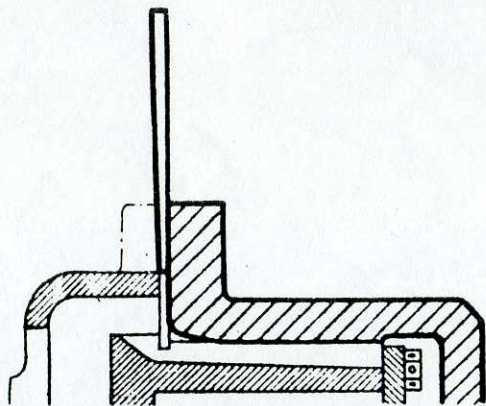

C

**Demontage
Dismantling**

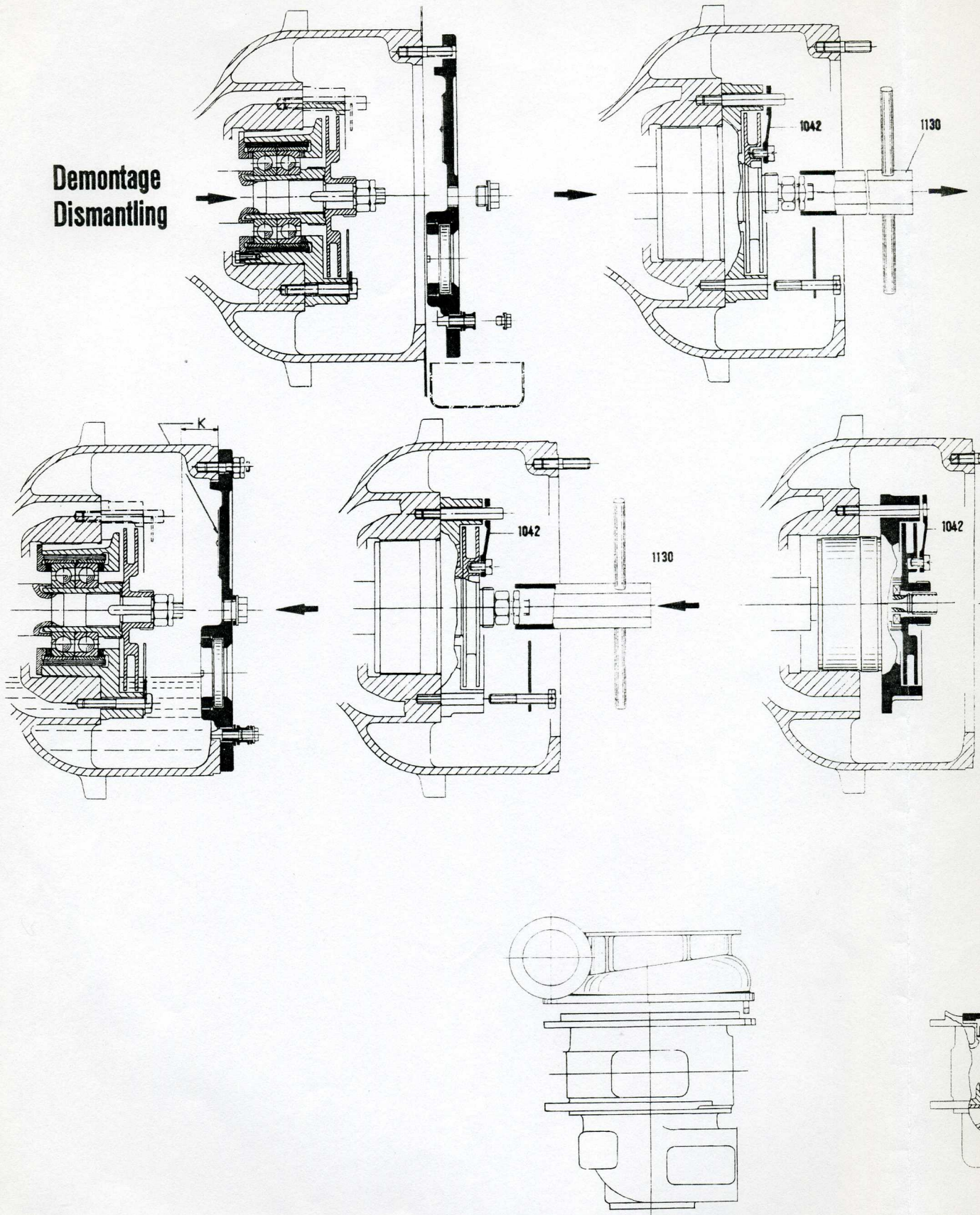

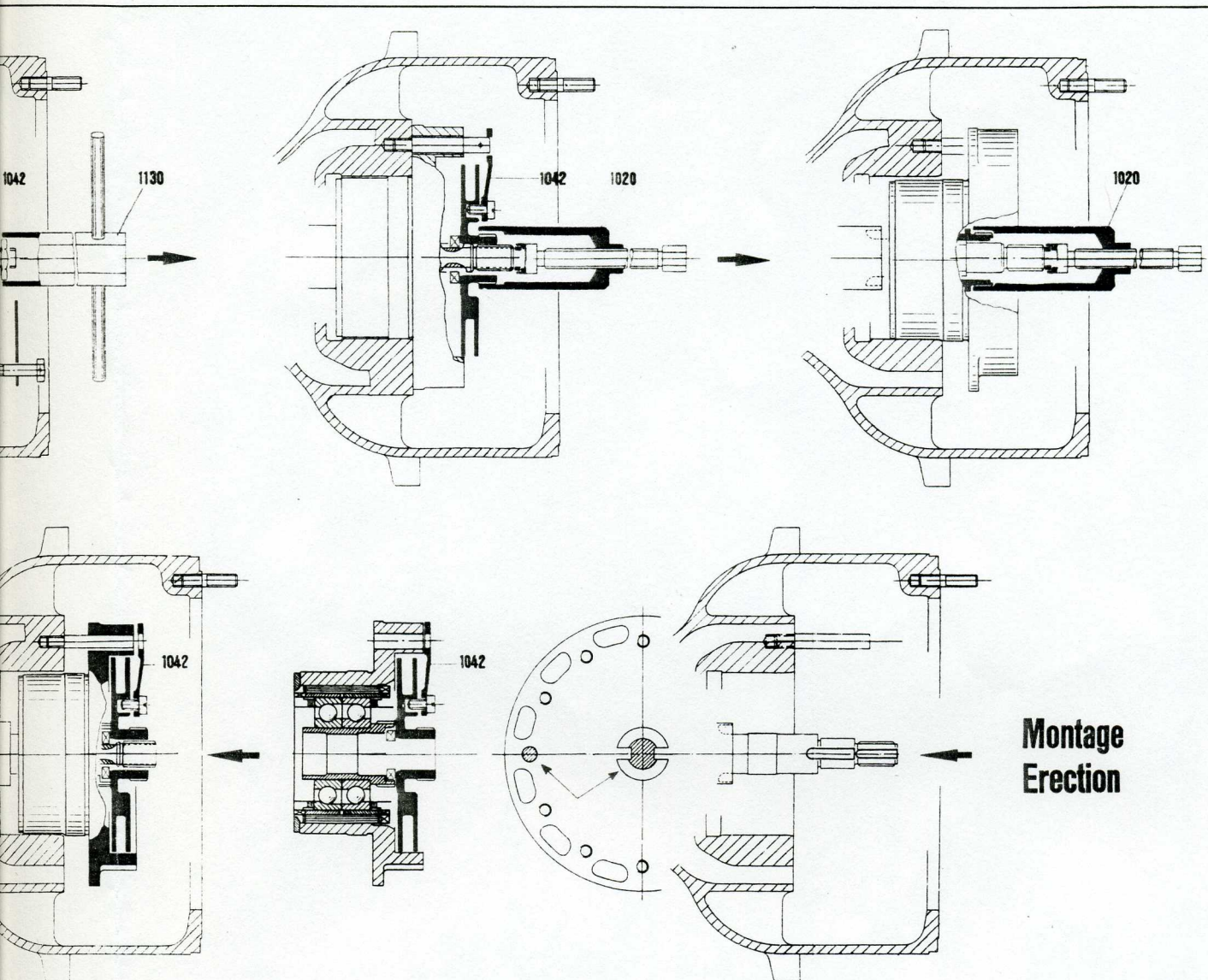

**Montage
Erection**

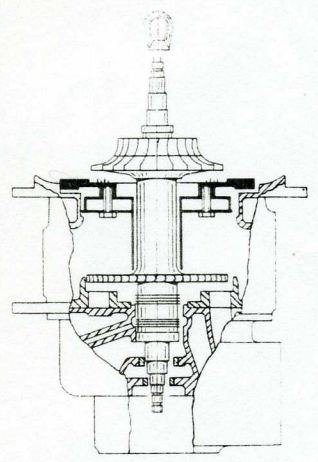

VTR 160, 200, 250

GT 864 526 B
Brown Boveri 

D

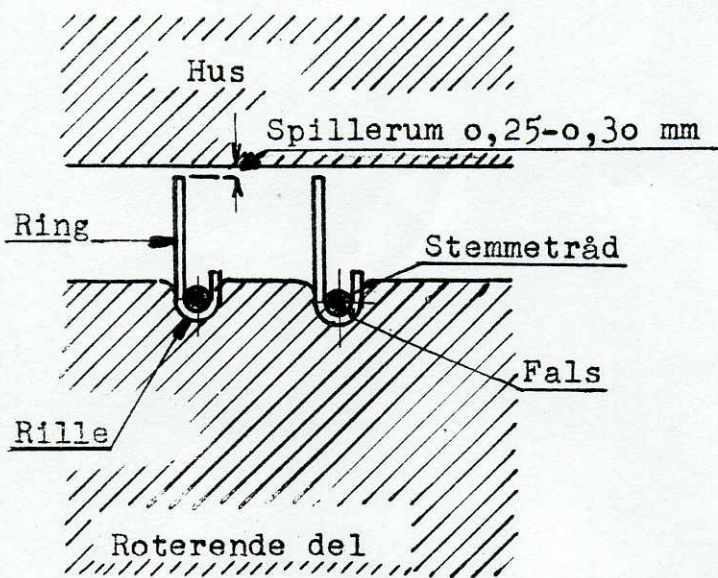

FIG. 1

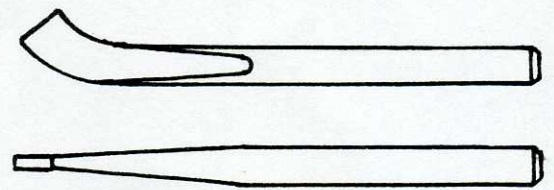

FIG. 2

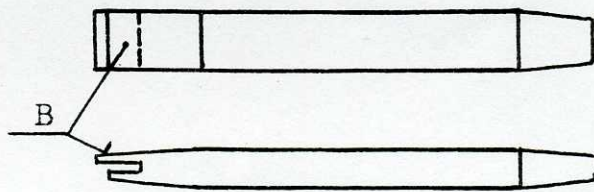
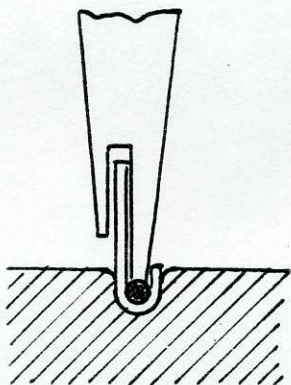

FIG. 3

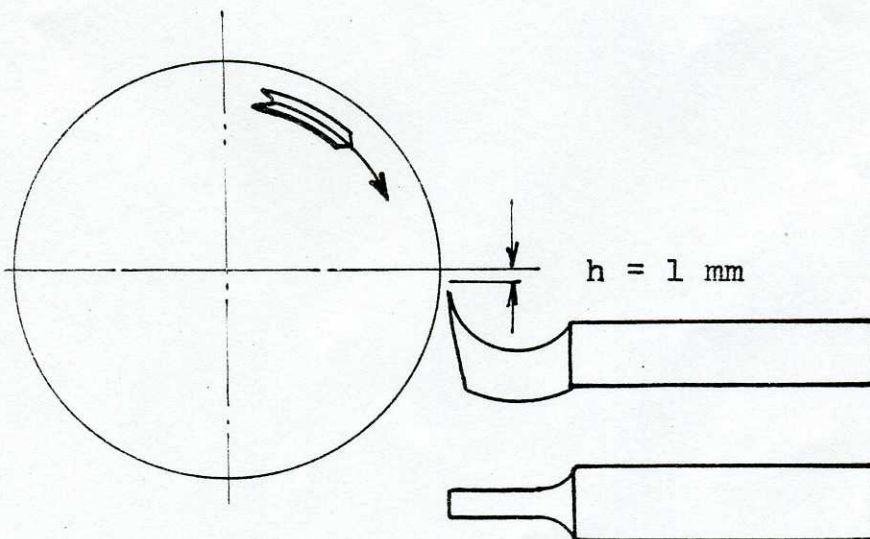
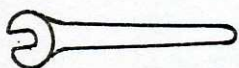

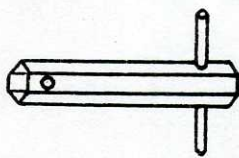

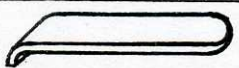

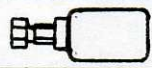
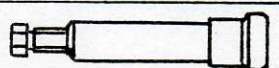



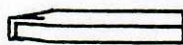
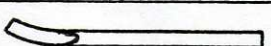
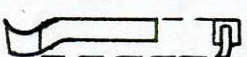
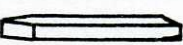

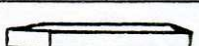

FIG. 4

Nr.	Antal	Betegnelse.	Anvendelse.	Skitse.
1101	1	Nøgle 22		
1102	1	" 17		
1110	1	" 9		
1119	1	" 11/14		
1130	1	Topnøgle 27		
1142	1	" 17		
1140	1	" 11		
1056	1	Sjømøtrik	Rotorakslen	
1135	1	Nøgle	Ringmøtrik for oliestandsglas	
1128	1	Skruestrækker		
1020	1	Aftrækker	Lejerne	
1025	1	"	Blæserhjul	
1042	1	Stoppeanordning	Rotor	
1048	1	Maaleanordning	Kuglelejer	
1049	1	Søger for "	"	
1090	1	Stemmer	Udskiftning	
1091	1	Mejsel	af	
1099	1	Drejestaal	tætningringe	
1092	1	Ringaabner		
	4	Skruer med sekskantet hoved	Stoppeanordning 1042	
1096	1	Mejsel	Udskiftning af tætningsringe i mellemvæg	
1097	1	Ringaabner		
				F

Zinkkörper für Korrosionsschutz

Corps de zinc pour protection contre la corrosion

Zinc body for protection against corrosion

Cuerpo de cinc para proteccion contra la corrosión

Corpo di zinco per la protezione contro la corrosione

Corpo de zinco de protecção contra a corrosão

VTR 160 ÷ 320

